

INSTRUCTION MANUAL

Two-Channel Charge Amplifier

UV-16



3-20-41 Higashimotomachi, Kokubunji, Tokyo 185-8533, Japan

<https://www.rion.co.jp/english/>

Organization of this manual

This manual describes the features, operation, and other aspects of the Two-Channel Charge Amplifier UV-16. If the unit is used together with other equipment to configure a measurement system, consult the documentation of all other components as well. The section starting on page iii contains important information about safety. Be sure to read and observe these precautions in full.

This manual contains the following sections.

Outline

Gives basic information about the unit and contains a block diagram.

Names of Parts and Functions

Briefly identifies and explains the front panel controls, rear panel connectors and all other parts of the unit.

Linking

Explains how to configure multiple units as a system.

Power Supply Connection

Explains how to make connections for powering the unit.

Accelerometer Selection and Connection

Explains the types of accelerometers that can be used, how to connect them, and how to set them up for measurement.

Output Connections

Explains how to use the output connectors on the rear panel.

Measurement

Explains the steps for setup and measurement.

Performance Characteristics

Contains charts that show the characteristics of the high-pass filter and low-pass filter as well as velocity (VEL) and displacement (DISP) frequency response characteristics.

Specifications

Lists the technical specifications of the unit.

Reference Material

Provides representative data for accelerometer inherent noise. Maintenance parts are also listed in this section.

- * Company names and product names mentioned in this manual are usually trademarks or registered trademarks of their respective owners.

FOR SAFETY

In this manual, important safety instructions are specially marked as shown below. To prevent the risk of death or injury to persons and severe damage to the unit or peripheral equipment, make sure that all instructions are fully understood and observed.



Disregarding instructions printed here incurs the risk of death or severe injury to persons.



Disregarding instructions printed here incurs the risk of injury to persons and/or damage to peripheral equipment.



Disregarding instructions printed here incurs the risk of damage to the product.

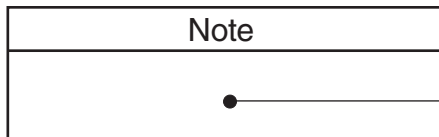

Additional information about using the unit. (These notes do not directly affect safety.)

This product can be used in any areas including residential areas.



The product described in this manual is in conformity with the following standards;

Electrical equipment for measurement control and laboratory use.

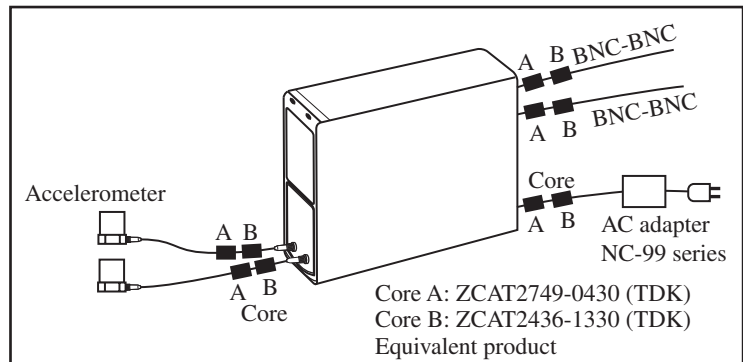

RION Co., Ltd.

3-20-41 Higashimotomachi, Kokubunji, Tokyo 185-8533, Japan

Precautions

- Operate the unit only as described in this manual.
- Do not disassemble the unit or attempt internal alterations.
- Observe the following precautions before using the unit:
 - Make sure that all connections are properly and safely established.
 - Make sure that the unit is operating normally.
- The permissible ambient temperature range for operation of the unit is -10°C to $+50^{\circ}\text{C}$. Relative humidity must be 90% or below.
- The power cord used to connect the optional AC adapter to an AC outlet is a 100 V AC cord for domestic use in Japan, which is compliant with Japanese laws and electrical safety standards. Do not use this power cord outside Japan or with any voltage other than 100 V AC. Otherwise, RION cannot guarantee the safety of the equipment. Use a power cable that is compliant with the laws and electrical safety standards of your location.
- If you notice any sign of a problem during use, disconnect the AC adapter or battery unit, and contact your supplier.
- Do not use or store the unit in locations which
 - may be subject to strong magnetic fields or strong radiation, or
 - may be subject to high levels of dust or splashes of water, or
 - may be subject to gases or air with high salt or sulphur content, or are in the vicinity of stored chemicals, or
 - may be subject to high temperature, humidity, or to direct sunlight, or
 - may be subject vibrations or shock.
- Always switch off the power after using the unit.
- When disconnecting cables, always hold the plug and do not pull the cable.
- Use only the specified AC adapter or other specified power source.
- This is a precision device. Take care not to drop the unit and protect it from shocks.
- The LCD panel of the unit can easily become scratched. Do not tap the panel with a pointed object such as a pencil, screwdriver, etc.
- In case of malfunction, do not attempt any repairs. Note the condition of the unit clearly and contact the supplier.
- When disposing of the unit, follow national and local regulations regarding waste disposal.

Contents

FOR SAFETY.....	iii
Precautions.....	v
Outline.....	1
Names of Parts and Functions.....	3
Front Panel.....	3
Rear Panel.....	5
Display screen.....	6
Bottom Panel.....	8
Top Panel.....	8
Linking.....	9
Linking procedure.....	9
Removing the link connector.....	14
Linking when using the Battery Unit BP-17.....	15
Using a single UV-16 unit.....	16
Power Supply Connection.....	17
Using an AC adapter.....	18
Using the Battery Unit BP-17.....	19
Accelerometer Selection and Connection.....	21
Accelerometer connection.....	22
Accelerometer Mounting.....	23
Output Connections.....	25
Measurement.....	26
Operation mode.....	26
Default settings.....	26
Accelerometer setup mode.....	27
Setup mode.....	29
Measurement mode.....	31
Bar graph indication.....	33
Output signal.....	33
Overload indicator LED.....	34
Calibration (CAL) mode.....	35

Performance Characteristics.....	37
Specifications	39
Rack Mounting Base	44
Reference Material	45
Lower measurement limit	45
Maintenance parts	46

Outline

The UV-16 is a two-channel charge amplifier for vibration measurements using piezoelectric accelerometers or accelerometers with integrated preamplifier. By linking the chassis of up to 16 units, a multi-channel configuration with up to 32 channels is possible. The main unit is equipped with an LCD panel, alarm LEDs, operation panel, input connectors (micro-dot), output connectors (BNC), DC IN jack, and link connector.

Power is supplied by the optional AC adapter NC-99 series (up to 16 UV-16 units). In configurations with a low number of channels (up to 3 units), the dedicated Battery Unit BP-17 (option) with 8 IEC R14 (size C) batteries can also be used.

UV-16 Block Diagram

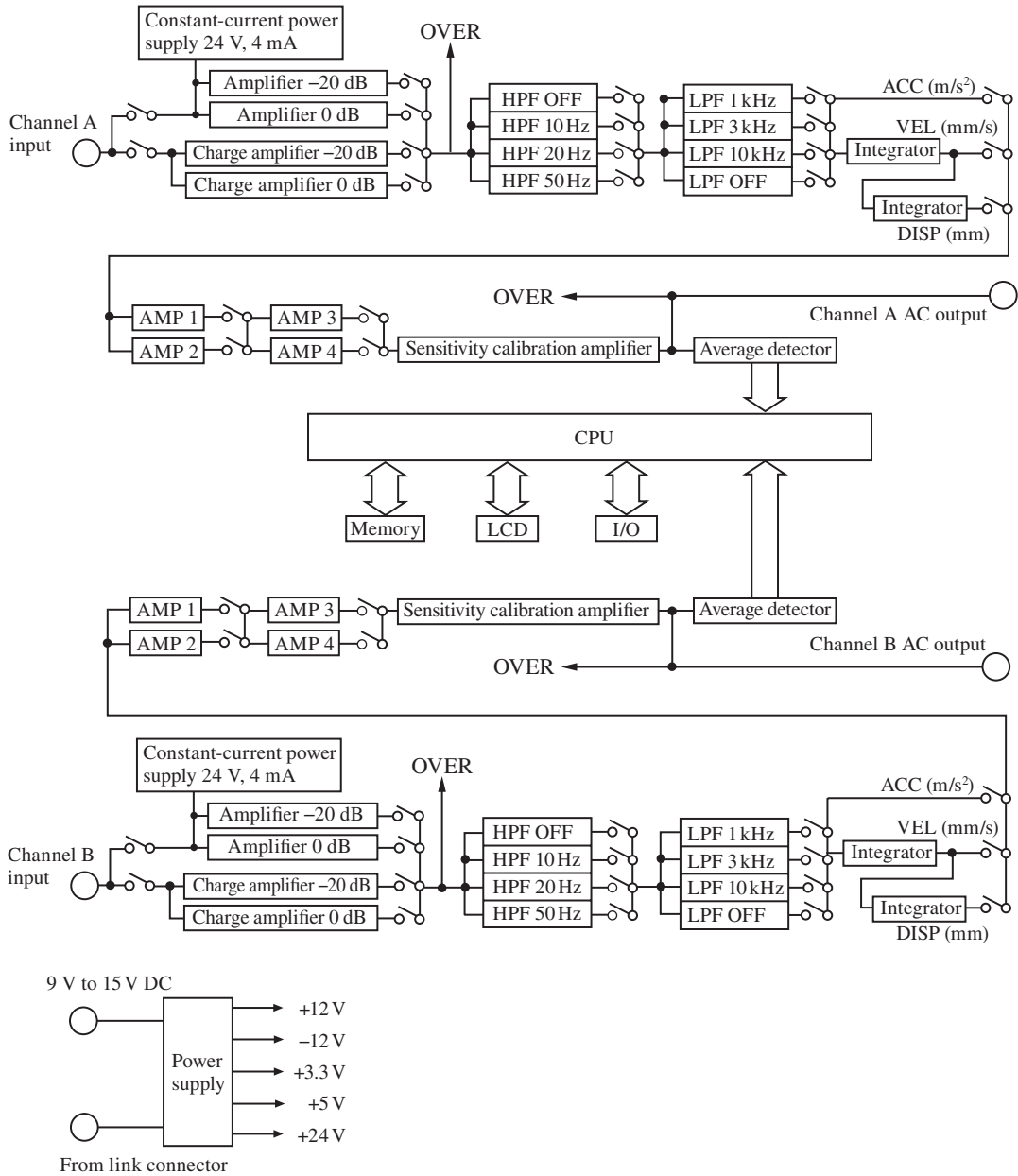

Names of Parts and Functions

Front Panel

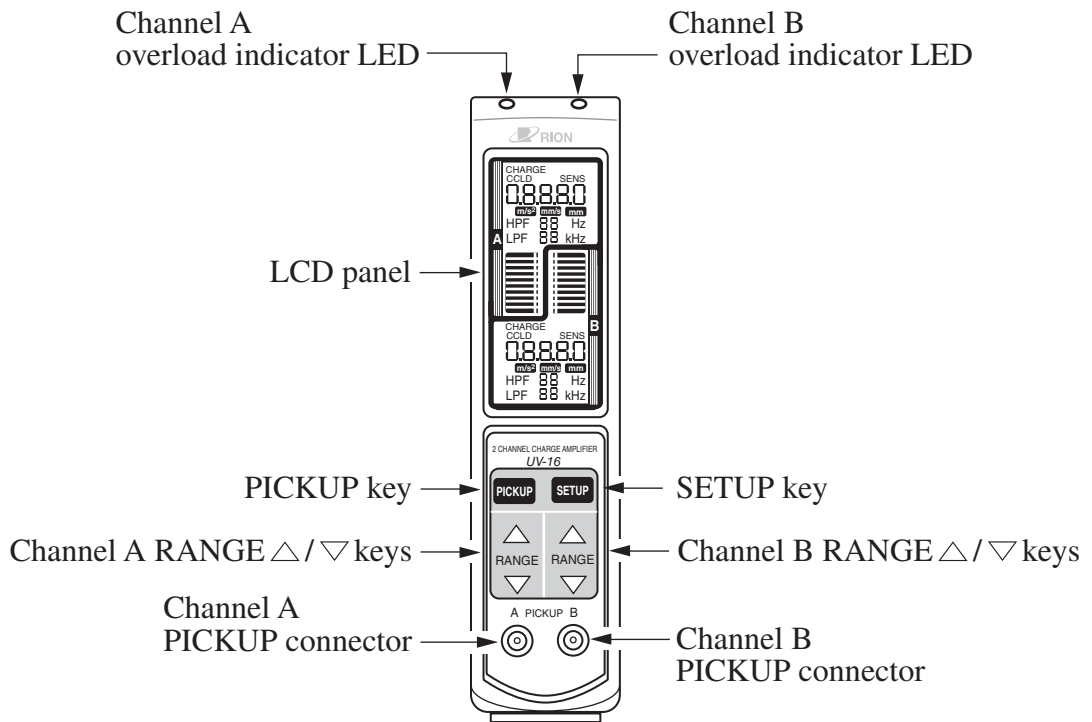

Channel A overload indicator LED

Lights up in red when saturation occurs in the internal amplifier circuitry for channel A.

While the LED is lit, correct measurement is not possible.

Channel B overload indicator LED

Lights up in red when saturation occurs in the internal amplifier circuitry for channel B.

While the LED is lit, correct measurement is not possible.

SETUP key

Pressing this key switches the unit to the following setup modes.

ACC (acceleration)/VEL (velocity)/DISP (displacement) setup

High-pass filter (HPF) setup

Low-pass filter (LPF) setup

Channel B RANGE \triangle / ∇ keys

Serve to select the range for channel B.

The \triangle key is also used to activate the CAL (calibration) mode.

Channel B PICKUP connector

Serves for connection of the piezoelectric accelerometer or accelerometer with integrated preamplifier.

Channel A PICKUP connector

Serves for connection of the piezoelectric accelerometer or accelerometer with integrated preamplifier.

Channel A RANGE \triangle / ∇ keys

Serve to select the range for channel A.

The \triangle key is also used to activate the CAL (calibration) mode.

PICKUP key

Pressing this key switches the unit to the accelerometer setup modes below.

Setup for piezoelectric accelerometer/accelerometer with integrated preamplifier

Sensitivity setup

LCD panel

Shows various setup parameters and comprises two bar graph displays.

(For details, see page 6.)

Rear Panel

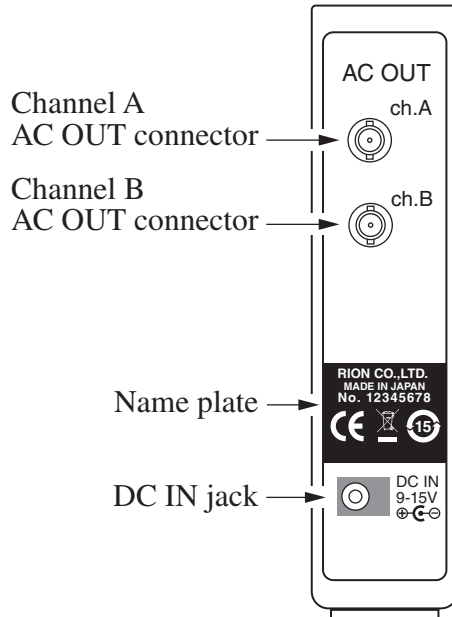

Channel A AC OUT connector

Supplies an AC signal for channel A.

Channel B AC OUT connector

Supplies an AC signal for channel B.

Name plate

Shows the serial number and other information about the unit.

DC IN jack

Serves for connection of the optional AC adapter or an external DC source.

Display screen

The display serves for both the A and B channel, but the items are the same, so the following explanation covers them together.

The illustration below shows all possible functions of the display. In actual operation, not all indicators will light up simultaneously.

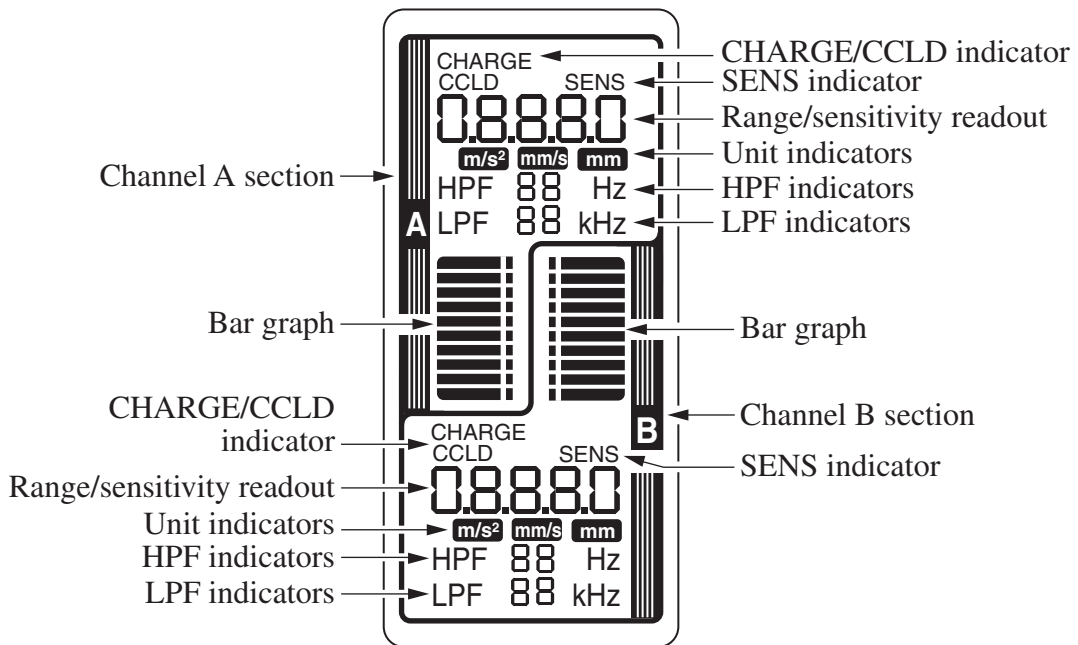

CHARGE/CCLD indicator

Shows the accelerometer setting. When using a piezoelectric accelerometer, select CHARGE. When using an accelerometer with integrated preamplifier, select CCLD.

SENS indicator

When the range/sensitivity readout shows the accelerometer sensitivity, the SENS indicator lights up.

Range/sensitivity readout

Normally, this shows the range setting.

In calibration mode, the indication “CAL” is shown.

In accelerometer setup mode, the sensitivity setting is shown.

Unit indicators

Show which unit is selected.

ACC (acceleration): m/s^2

VEL (velocity): mm/s

DISP (displacement): mm

HPF indicators

Show the high-pass filter setting (OFF, 10 Hz, 20 Hz, 50 Hz). OFF is indicated by "--".

LPF indicators

Show the low-pass filter setting (1 kHz, 3 kHz, 10 kHz, OFF). OFF is indicated by "--".

Bar graph

Shows the level of the accelerometer signal as a bar graph indication. The refresh rate of the display is 100 milliseconds.

Note
The display backlight is always on when the unit is powered from an AC adapter. When the unit is powered from batteries using the Battery Unit BP-17, the display backlight is activated for 10 seconds when any key is pressed.

Bottom Panel

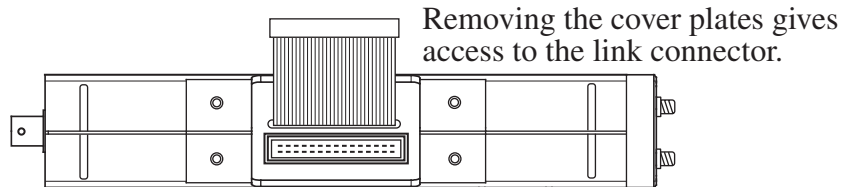
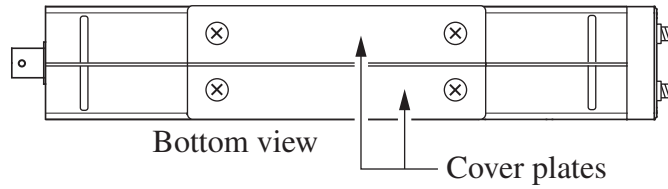

To access the link connector for linking units, remove the cover plates on the bottom of the unit. The connector is used to supply power to multiple units. Use the supplied link plate to join multiple units.

Top Panel

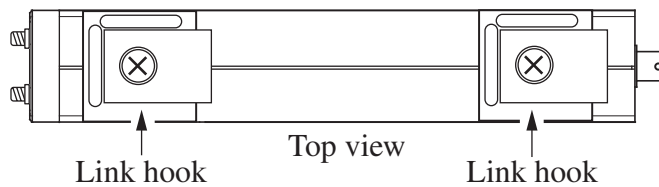

The top panel of the unit has two hooks which can be used to join multiple units together.

Linking

Multiple UV-16 units can be linked to form a multi-channel system. The maximum number of units that can be linked is 16 (resulting in 32 channels). When using the Battery Unit BP-17 to power the units, the maximum number of units that can be linked is three.

Required tool: 1 Phillips screwdriver (JIS B 4633:1998, type H, No. 2)

Important
<p>Precautions for linking units</p> <ul style="list-style-type: none">● Make sure that power is OFF before starting:<ul style="list-style-type: none">• Disconnect AC adapter.• When using Battery Unit BP-17: Remove batteries● Do not use any screws other than the ones supplied with the product.● Do not insert any objects (pieces of metal, pencil lead, etc.) into the unit.● Use only the specified screwdriver (Phillips screwdriver, JIS B 4633:1998, type H, No. 2). Otherwise the cross-shaped slots on the screw heads may be damaged.

Linking procedure

1. Remove the 4 screws holding the cover plates on the bottom of the unit, and remove the cover plates. Do this for all units that are to be connected. Put the screws and cover plates in a box or other suitable container, to make sure that you do not lose any parts. The parts will be required later for reassembly.

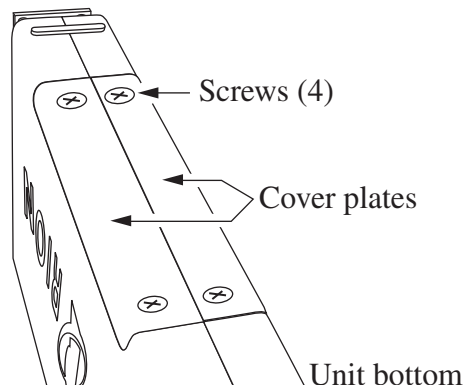

2. Remove the two link hooks on the top panel. Do not remove these hooks for the unit that will be the rightmost unit as seen from the front.

Put the screws and hooks in a box or other suitable container, to make sure that you do not lose any parts. The parts will be required later for reassembly.



3. For the leftmost unit as seen from the front, roll up the link cable around the connector and push it into the empty space in the unit.

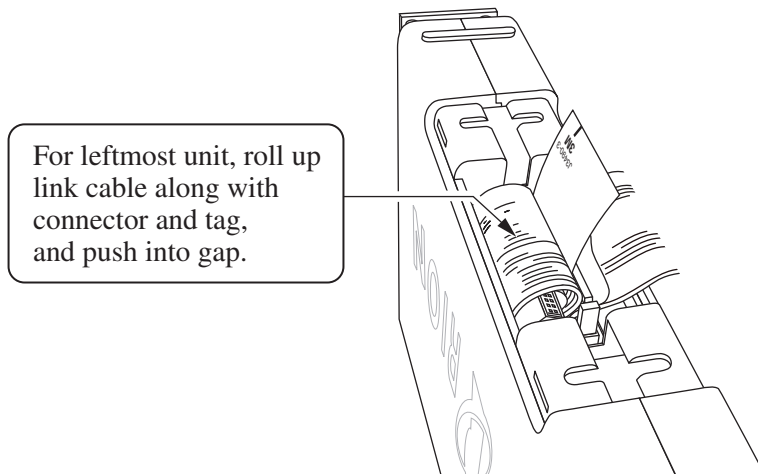

4. Plug the link connector of each unit into the next unit.

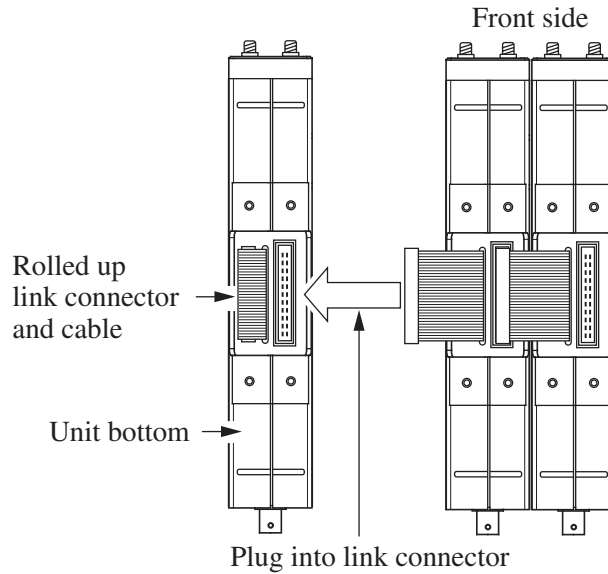

5. After plugging in the link connectors, use the supplied link plates and screws to provisionally link the units as shown below. Use the screws removed in step 1.

Why not to use other screws:

Too short screws will not properly secure the plate.

Too long screws may damage parts inside the unit.

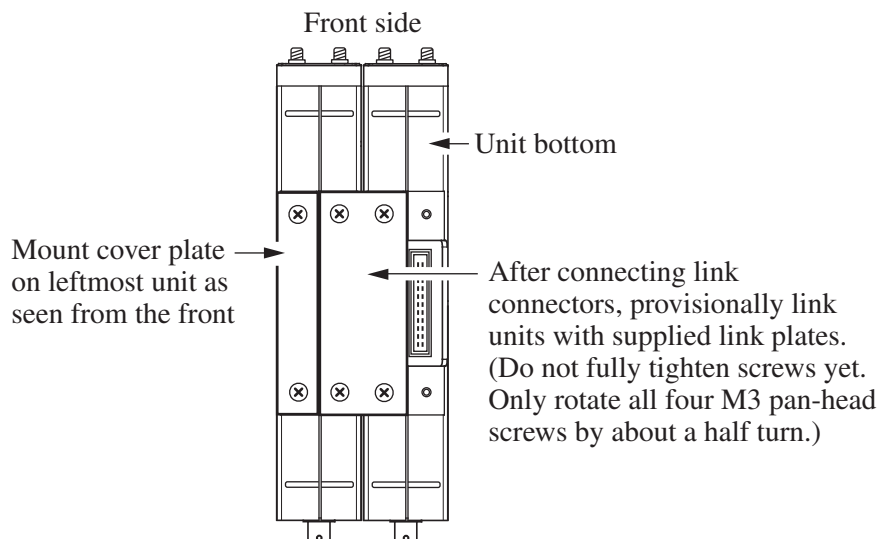

- Attach the link hooks removed in step 2 to the unit tops, so that the units are locked together.

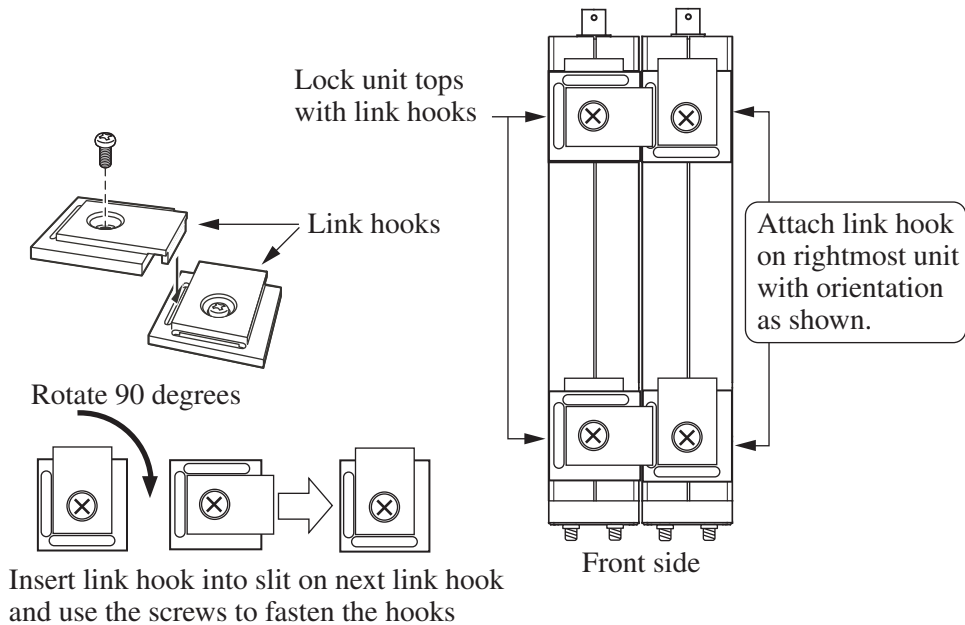

- Make sure that all link connectors are plugged in, and sequentially link the units with the supplied link plates.

Attach the cover plates to the leftmost and rightmost unit.

Use the screws removed in step 1 to fasten the plates.

Why not to use other screws:

Too short screws will not properly secure the plate.

Too long screws may damage parts inside the unit.

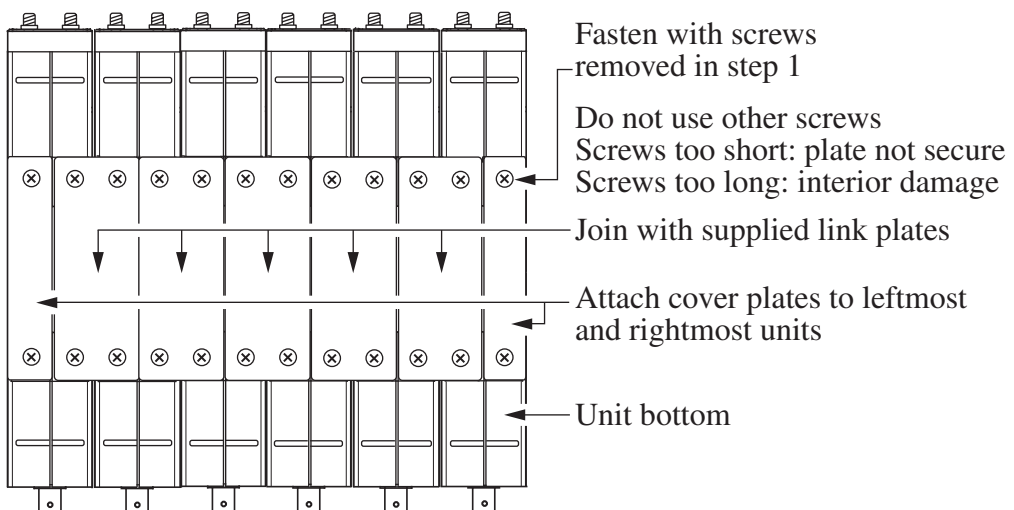

8. Attach the link hooks to the unit tops, so that the units are locked together.

Securely tighten the screws.

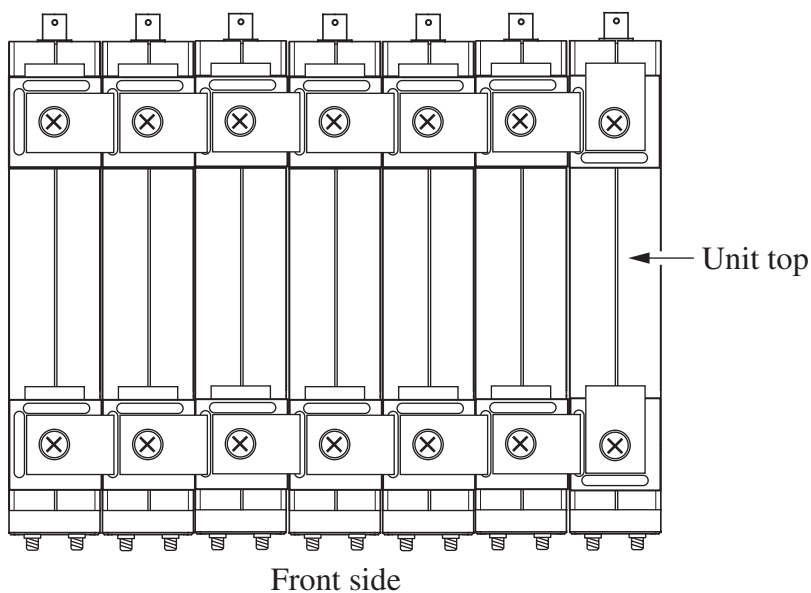

Note

If you have lost the original screws, refer to the information about maintenance parts on page 46. Commercially available screws can also be used, provided that exact specifications are met.

Fastening screw for link hook on unit top

Truss-head screw M4 × 8 (screw length 8 mm)

Fastening screw for link plate on unit bottom

Pan-head screw M3 × 10 (screw length 10 mm)

Screw types listed according to JIS B 1111.

Removing the link connector

To unplug the link connector, grasp the tag as shown in the illustration below and carefully pull the connector out.

Important
Be sure to grasp the side with the “3M” lettering. If you pull on the other side, the tag may break.

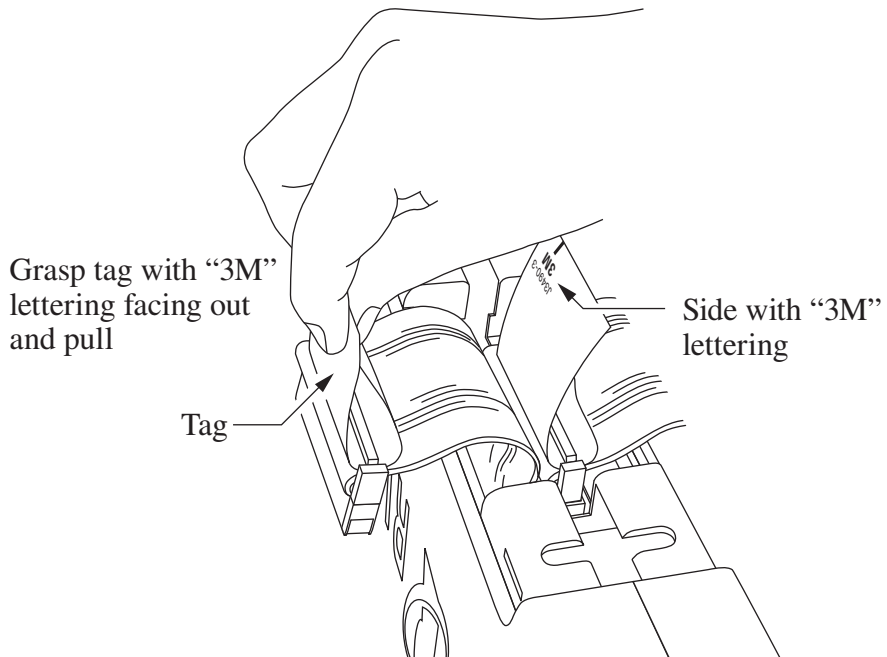

Linking when using the Battery Unit BP-17

Install the Battery Unit BP-17 as the rightmost unit of the system as seen from the front.

The cover of the battery compartment in the Battery Unit BP-17 is located on the right side. When installed in this way, the cover can be opened to access the compartment and insert/remove batteries.

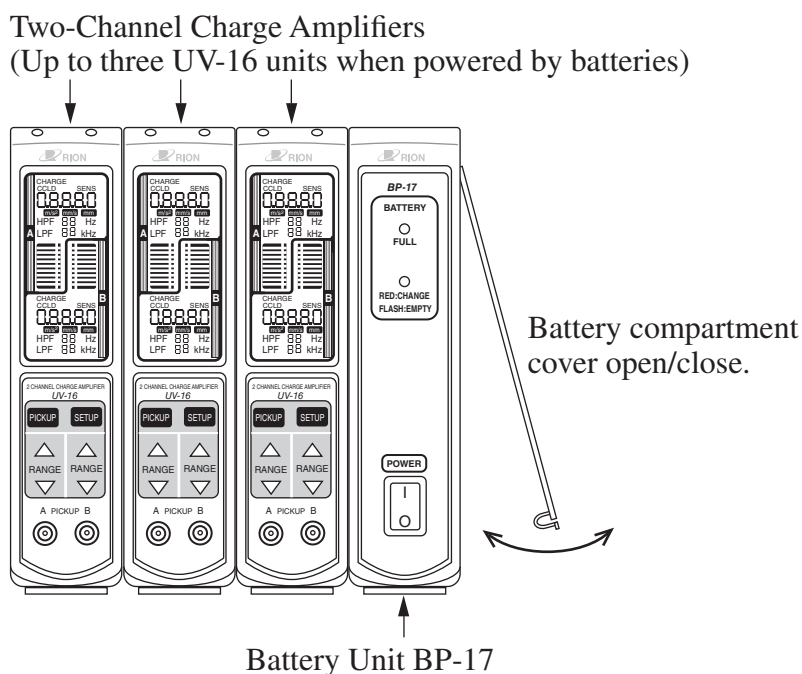

Note

The AC adapter NC-99 series can power up to 16 linked UV-16 units.

Using a single UV-16 unit

Attach the supplied link plate to the bottom of the unit as shown below, to stabilize the unit when it is used in a free-standing configuration.

Use the screws removed from the unit.

Why not to use other screws:

Too short screws will not properly secure the plate.

Too long screws may damage parts inside the unit.

1. Remove two screws from the cover plates on the bottom of the unit (the two screws that are nearer to the front side). Refer to the left-side illustration (Fig. 1) below.
2. Use the screws removed in step 1 to fasten the supplied link plate sideways, Refer to the right-side illustration (Fig. 2) below.

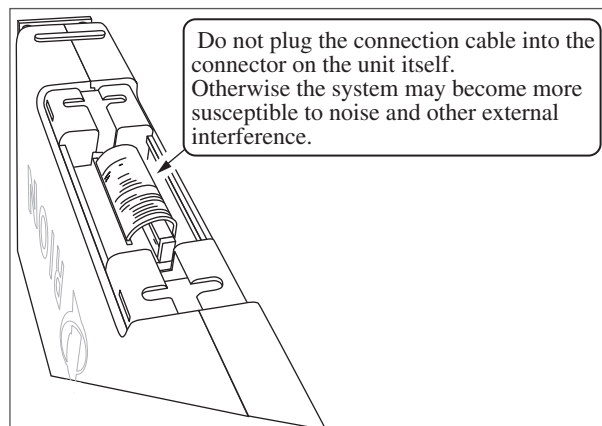
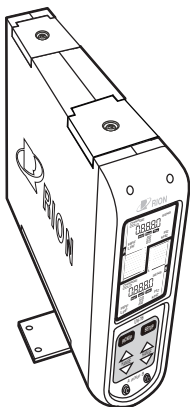
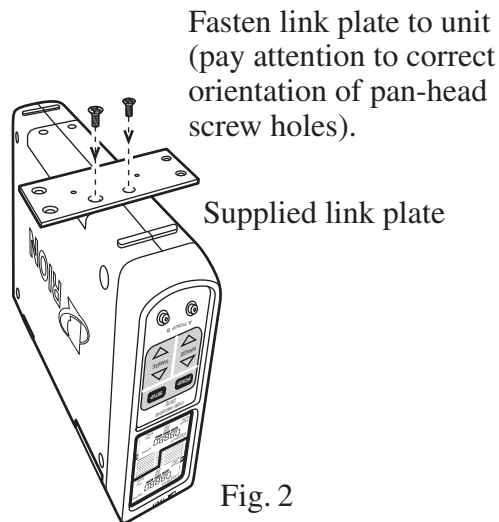
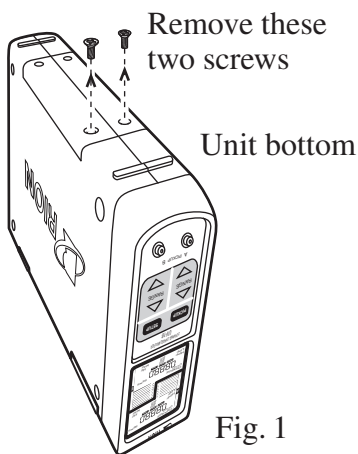

Power Supply Connection

The UV-16 can be powered from an AC adapter (option), the Battery Unit BP-17 (option), or a car battery (12 V).

The UV-16 does not have a power switch. It will start to operate when power is supplied.

The Battery Unit BP-17 (option) has a power switch which allows shutting down the system.

Important

When using multiple units in a linked configuration, make sure that system assembly is fully completed before supplying power.

Power supply limitations		
Power supply type	Max. number of units	
AC adapter (option)	NC-99 series	Up to 16
Battery Unit BP-17 (option)	IEC R14 (size C) battery × 8	Up to 3

Note

The display backlight is always on when the unit is powered from an AC adapter. When the unit is powered from batteries using the Battery Unit BP-17, the display backlight is activated for 10 seconds when any key is pressed.

To power a system in which the Battery Unit BP-17 is installed from an AC adapter, be sure to connect the AC adapter to the BP-17.

The UV-16 does not have a power switch. It will start to operate when power is supplied.

Using an AC adapter

⚠ Caution

Be sure to use only a single AC adapter to power a linked system consisting of multiple Two-Channel Charge Amplifier UV-16 units.

Important

Do not use any AC adapter other than the specified models. Otherwise malfunction and damage may occur.

If no Battery Unit BP-17 is installed in the system, the AC adapter may be connected to any UV-16 unit.

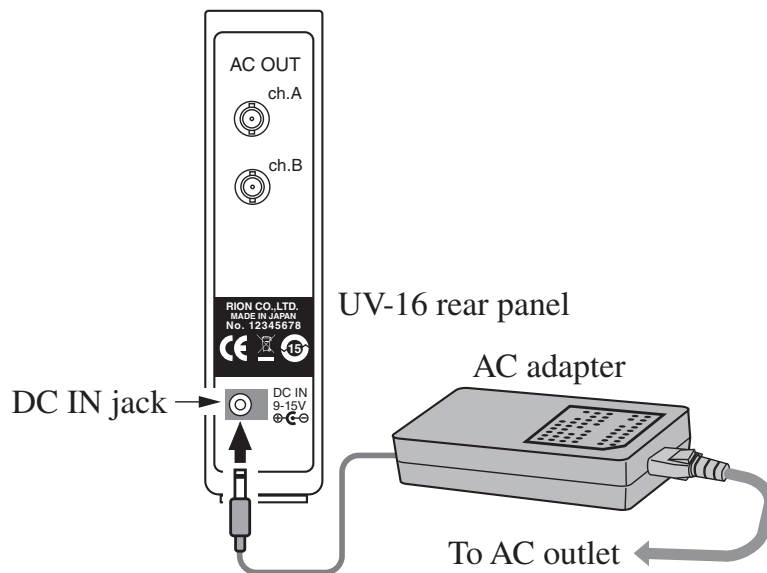

Using the Battery Unit BP-17

Battery life

Figures for approximate battery life when using the Battery Unit BP-17 are given below.

These figures are for using three UV-16 units.

Manganese batteries	Alkaline batteries
Approx. 5 hours	Approx. 17 hours

* Continuous operation at ambient temperature of 25°C, with CHARGE setting, normal operation mode

For instructions on how to insert batteries and other information, please refer to the documentation of the BP-17.

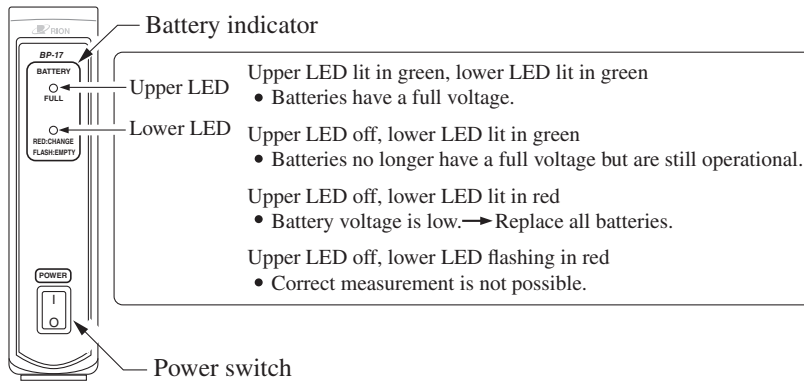

Battery Unit BP-17

Important
When the upper LED is off and the lower LED lights up in red, you should replace the batteries with a fresh set.
When the lower LED is flashing in red, correct measurement is no longer possible.
Before replacing the batteries, be sure to set the power switch to OFF (press ○ side).
When inserting batteries, take care not to mix up “+” and “-” polarity.
Always replace all eight batteries together. Using a mixture of old and new batteries or batteries of a different type can lead to malfunction and damage.
When not using the unit, remove the batteries to guard against the risk of damage by leaking battery fluid.
When powering a system from batteries using the BP-17, the maximum number of UV-16 units that can be linked is three.

The Battery Unit BP-17 has a DC IN jack on the rear panel. To power the system from an optional AC adapter, connect the adapter to this jack.

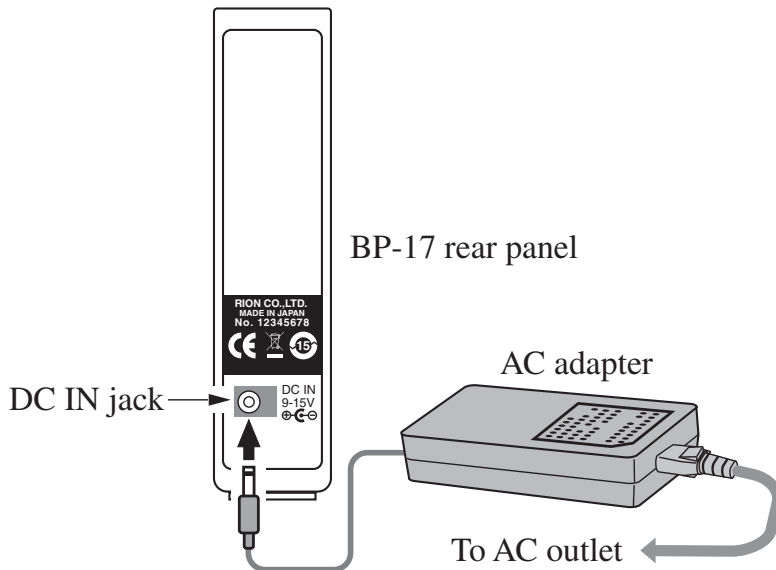

Important

Do not use any AC adapter other than the specified models. Otherwise malfunction and damage may occur.

If an AC adapter is used to power the system, operation during a power failure is not assured.

Note

The Battery Unit BP-17 does not have a charging function.

To power a system in which a Battery Unit BP-17 is installed from an AC adapter, be sure to connect the AC adapter to the BP-17.

Accelerometer Selection and Connection

Two types of accelerometers can be connected to the UV-16.

Accelerometer type	Sensitivity setting range
Piezoelectric accelerometer	0.100 pC/(m/s ²) to 99.9 pC/(m/s ²)
Accelerometer with integrated preamplifier	0.100 mV/(m/s ²) to 99.9 mV/(m/s ²)

Important

Before connecting or disconnecting an accelerometer, be sure to turn off the power supply to the system.

Major piezoelectric accelerometer from Rion (representative values)

	Compact/lightweight	General	High-output	High-temperature	3-axis	
Model	PV-90B	PV-85	PV-87	PV-65	PV-97C	PV-93
Mass (g)	1.2	23	115	26	4.7	30
Sensitivity (pC/(m/s ²))	0.18	6.42	40	7.14	0.12	0.831
Frequency range (Hz)*1	1 to 25000	1 to 7000	1 to 3000	1 to 9000	1 to 10000 (X/Y) 1 to 15000 (Z)	1 to 8000 (axis 2) 1 to 4000 (axis 1/axis 3)
Mounting resonance frequency (kHz)*2	70	24	9	25	---	---
Connection cable*3	VP-51L	VP-51A	VP-51A	VP-51B	VP-51L × 3	VP-51C × 3

Major accelerometers with integrated preamplifier from Rion (representative values)

	Compact/lightweight	
Model	PV-91C	PV-91CH
Mass (g)	1.8	3
Sensitivity (mV/(m/s ²))*1	1	11
Frequency range (Hz)*2	1 to 20000 *4	1 to 15000 *5
Mounting resonance frequency (kHz)*2	55	50
Connection cable*3	VP-51LC	VP-51LC

*1 For actual sensitivity values, see sensitivity chart supplied with accelerometer.

*2 Representative value when mounted on a flat surface using standard mounting method

*3 Supplied with accelerometer

*4 At 150°C to 170°C, 1 Hz to 2 Hz (±15%)

*5 0.6 Hz to 20 kHz, 0.5 Hz to 20 kHz (±30%)

Accelerometer connection

Connect the accelerometer to the PICKUP connector on the UV-16, as shown in the illustration below.

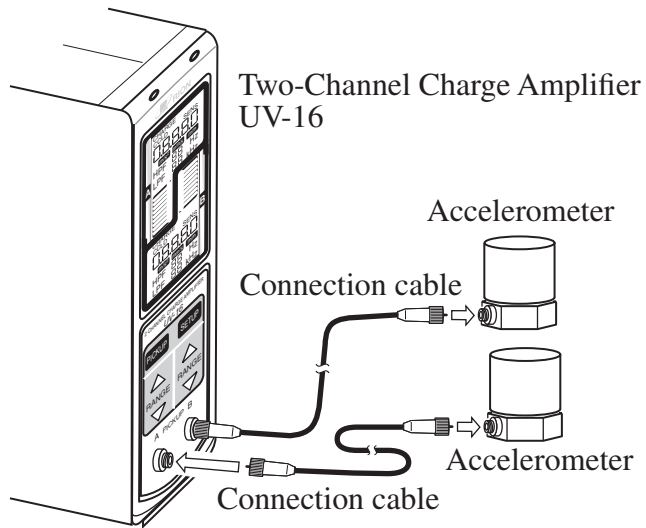

Accelerometer Mounting

The UV-16 is a vibration measurement amplifier designed for use with piezoelectric accelerometer or accelerometer with integrated preamplifier. Other types of accelerometers such as electrokinetic accelerometers cannot be used with this product. Choose a suitable accelerometer according to the measurement requirements including measurement range, frequency range, and environmental conditions. The accelerometer mounting method has a significant effect on the reliability of measurement data, and it will greatly affect the contact resonance frequency. The advantages and disadvantages of various mounting methods are outlined below. Refer to this information when making your selection.

Rigid screw mounting

This mounting principle assures optimum frequency response characteristics. The mounting surface should be perfectly smooth, and the screw holes must be drilled in such a way as to assure perfect perpendicularity of the accelerometer.

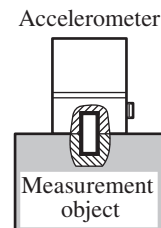

Insulation attachment mounting

This mounting principle is used when electrical insulation between accelerometer and measurement object is required. The contact resonance frequency will be lower than with rigid screw mounting. Regarding the screw holes, the same precautions as for rigid screw mounting apply.

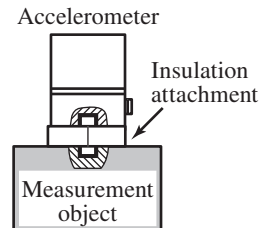

Magnet attachment mounting

Because the contact resonance frequency will be quite low, this principle is mainly suited for vibration measurements in the medium to low frequency range. The maximum acceleration that can be measured depends on the accelerometer mass.

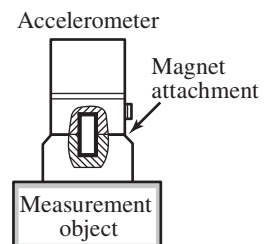

Rod attachment mounting

Pressing the accelerometer against the measurement object with a rod is the simplest method, but the measurement frequency range would be about several hundred Hz, because the contact resonance frequency will be very low. This method should only be used if none of the other three mounting methods are feasible.

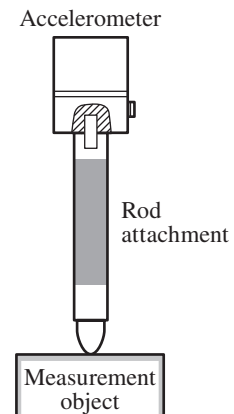

⚠ WARNING

When performing measurements on machinery with exposed rotating parts or drive train parts, proceed with utmost caution to avoid the risk of getting caught in the machinery.

Note

Tighten the M6 screw first on the piezoelectric accelerometer side and then mount the rod attachment.

Output Connections

The rear panel of the UV-16 provides one AC output connector each for channel A and channel B. This signal can be supplied for example to an oscilloscope for waveform observation, to a data recorder for recording, or to an FFT analyzer for analysis. The calibration signal (see page 35) is also output from this connector.

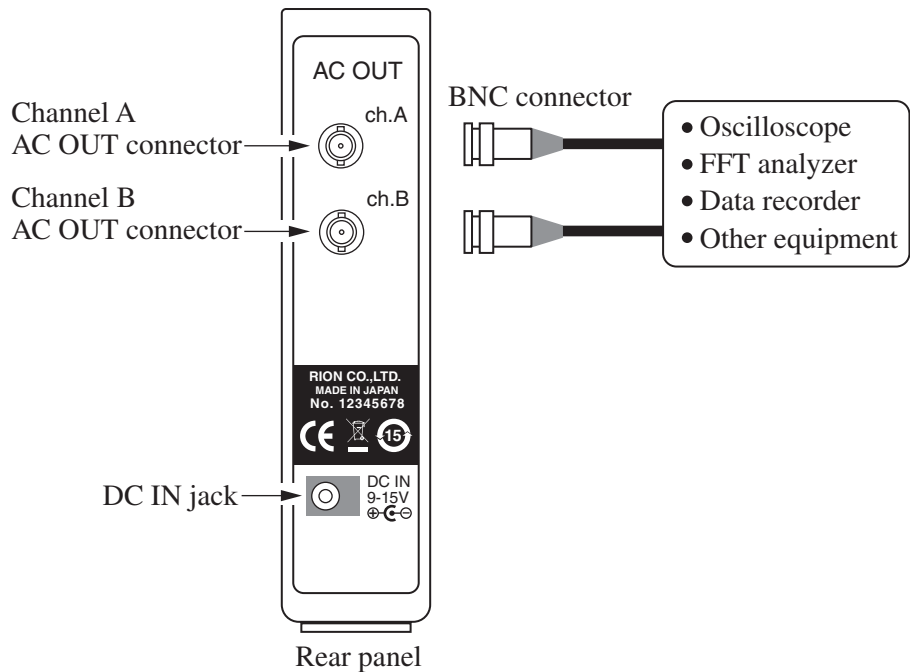

Output type:	AC output
Connector type:	BNC
Output impedance:	approx. 50 ohms
Output voltage (at range full-scale point):	1 V (Peak)
Maximum output voltage:	approx. ± 10 V (Peak) (no-load condition)
Load impedance:	10 kilohms or higher

Measurement

Operation mode

The operation modes of the UV-16 are listed below.

Operation mode	Outline
Accelerometer setup mode	Make accelerometer sensitivity settings
Setup mode	Make acceleration/velocity/displacement settings, HPF setting, LPF settings
Measurement mode	Make measurements
Calibration (CAL) mode	Use a calibration output signal to calibrate external equipment

Default settings

If power is supplied while holding down the SETUP key, the resume information* is cleared, and the unit starts up with the default settings listed below. When starting up with the default settings, the range/sensitivity readout shows the indication $\downarrow \uparrow$ for about 10 seconds.

Default settings (common for both channels)

Input setting: CHARGE
 Sensitivity setting: 5.00
 Measurement mode: Acceleration (ACC) m/s²
 Range: 100
 HPF: OFF (indication --)
 LPF: OFF (indication --)

* Resume information: All settings are automatically memorized when power is turned off.

When power is turned on, the settings are established again.

When power comes on, the sensitivity value at the last power off point flashes for about 10 seconds on the range/sensitivity readout.

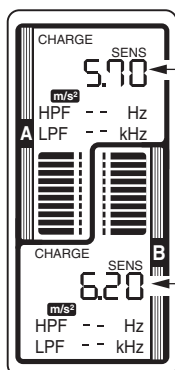

Previously selected sensitivity setting flashes for about 10 seconds.

Accelerometer setup mode

This mode serves for making accelerometer related settings for the UV-16. Before starting a measurement, be sure to make or check the accelerometer setting.

Setting item	Setting content	Remarks
Piezoelectric accelerometer	CHARGE	Setting is made separately for channel A and B
Accelerometer with integrated preamplifier	CCLD	
Sensitivity	0.100 to 0.999 in 0.001 steps 1.00 to 9.99 in 0.01 steps 10.0 to 99.9 in 0.1 steps	Setting is made separately for channel A and B

Setting procedure

- Pressing the PICKUP key in measurement mode activates the accelerometer setup mode.

Make the setting as required by the connected accelerometer.

- Piezoelectric accelerometer connected: Select CHARGE
- Accelerometer with integrated preamplifier connected: Select CCLD

Use the RANGE Δ / ∇ keys for the respective channel to make the setting. The indicator for the selected channel flashes, and the other indicator is off.

When the setting has been made with the RANGE Δ / ∇ keys for channel A and channel B, press the PICKUP key.

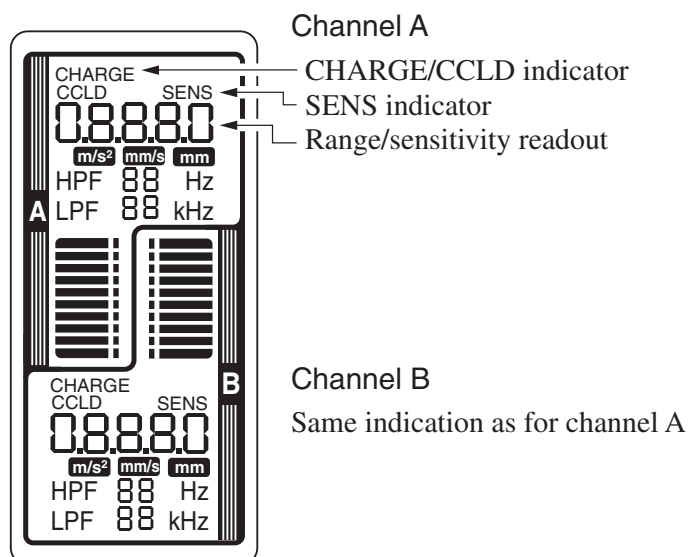

- Pressing the PICKUP key again in the condition of step 1 activates the sensitivity (SENS) setup display.

The sensitivity value can be changed with the RANGE Δ / ∇ keys for the respective channel.

Holding down a key causes the range setting to change quickly.

The setting can be made for three effective digits.

When the setting has been made for channel A and channel B, press the PICKUP key.

Charge sensitivity

圧電式加速度ピックアップ校正表
Calibration Data

型式 PV-***
Model

製造番号 *****
Serial No.

電荷感度 (80 Hz) 5.90 pC/(m/s²)
Charge Sensitivity

横感度比 (30 Hz) ** %
Transverse Sensitivity

静電容量 *** pF
Capacitance

測定温度 * °C
Temperature

測定年月 *
Data

検査責任者
Inspected by

検印

リアン株式会社 RION CO., LTD.

Channel A

Set to CHARGE

SENS

Set to charge sensitivity as indicated in calibration data chart

Hold down RANGE Δ / ∇ keys for rapid change

Channel B setting is for charge sensitivity of other accelerometer

Note
Sensitivity setting units pC/(m/s ²): CHARGE mV/(m/s ²): CCLD

- When you press the PICKUP key, the unit returns to the measurement mode, and accelerometer related setup is complete.

By pressing the SETUP key at any point during step 1 or step 2, the current setting can be made active immediately. The unit returns to measurement mode.

Setup mode

This mode serves for making settings for acceleration/velocity/displacement and for the high-pass filter (HPF) and low-pass filter (LPF).

Before starting a measurement, be sure to make or check these settings.

Setting item	Setting content	Remarks
Acceleration/velocity/ displacement	m/s ² : ACC (acceleration)	Setting is made separately for channel A and B
	mm/s: VEL (velocity)	
	mm: DISP (displacement)	
HPF (High-pass filter)	OFF, 10 Hz, 20 Hz, 50 Hz	Setting is made separately for channel A and B
LPF (Low-pass filter)	1 kHz, 3 kHz, 10 kHz, OFF	

Setting procedure

1. Pressing the SETUP key in measurement mode activates the setup mode and allows selection of acceleration/velocity/displacement.

Use the RANGE Δ / ∇ keys for the respective channel to make the setting.

Acceleration (ACC): Select m/s²

Velocity (VEL): Select mm/s

Displacement (DISP): Select mm

When the unit has been selected for channel A and channel B, press the SETUP key.

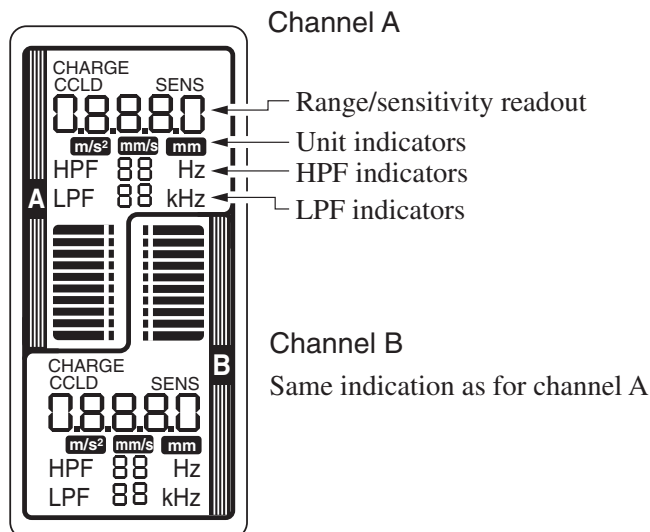

- Pressing the SETUP key again in the condition of step 1 switches to the HPF setup display.

Use the RANGE Δ / ∇ keys for the respective channel to make the HPF setting.

OFF: Select -- Hz
 10 Hz: Select 10 Hz
 20 Hz: Select 20 Hz
 50 Hz: Select 50 Hz

For information on electrical frequency response characteristics, refer to page 37.

When the HPF setting has been selected for channel A and channel B, press the SETUP key.

- Pressing the SETUP key again in the condition of step 2 switches to the LPF setup display.

Use the RANGE Δ / ∇ keys for the respective channel to make the LPF setting.

1 kHz: Select 1 kHz
 3 kHz: Select 3 kHz
 10 kHz: Select 10 kHz
 OFF: Select -- kHz

For information on electrical frequency response characteristics, refer to page 37.

When the LPF setting has been selected for channel A and channel B, press the SETUP key.

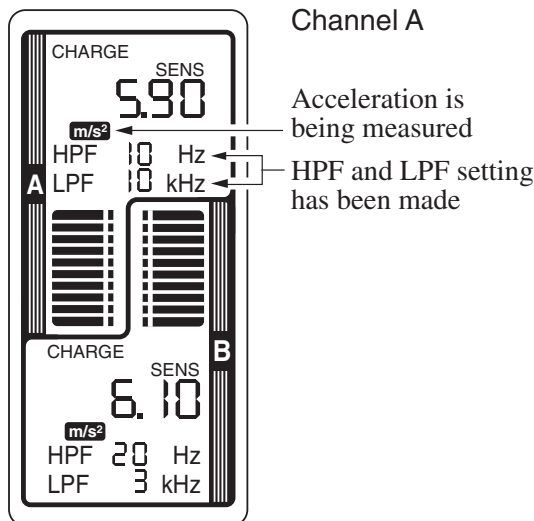

- When you press the SETUP key, the unit returns to the measurement mode, and setup is complete.

By pressing the SETUP key at any point during steps 1 to 3, the current setting can be made active immediately. The unit returns to measurement mode.

Measurement mode

Vibration measurements are carried out in measurement mode.

The bar graph indication changes according to the vibration detected by the accelerometer, and a corresponding AC signal is supplied at the AC OUT connectors.

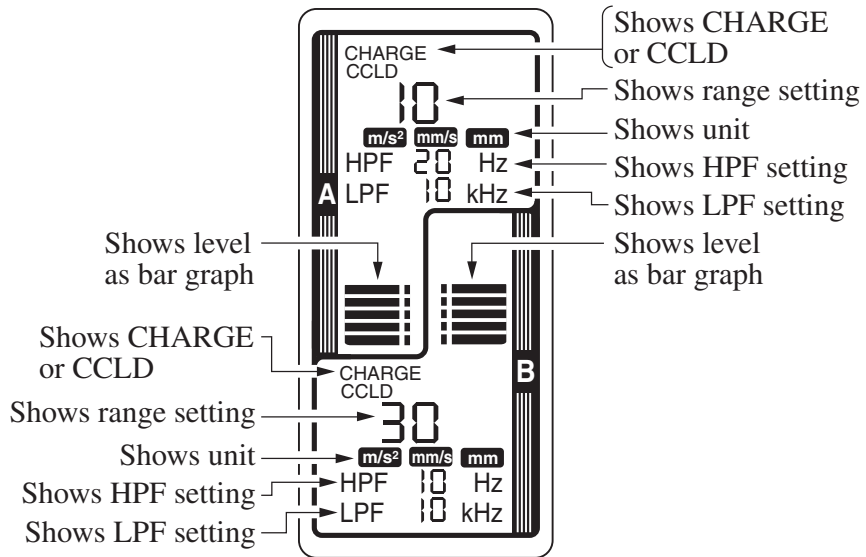

Note

When the range setting is 0.03, 0.3, 3, 30, 300, or 3000, the range full-scale values will be 0.0316, 0.3162, 3.162, 31.62, 316.2, or 3162 respectively.

Changing the range setting

To change the range setting, use the RANGE \triangle / ∇ keys.

If the signal from the accelerometer is too high for the selected range, the internal amplification circuits will saturate, causing the overload indicator LED to light up. In such a case, correct measurement is not possible, and you should change the range setting.

Sensitivity	Acceleration/velocity/displacement	Range setting
0.100 to 0.999	Acceleration (m/s ²)	10 to 10000
	Velocity (mm/s)	10 to 10000
	Displacement (mm)	1 to 1000
1.00 to 9.99	Acceleration (m/s ²)	1 to 1000
	Velocity (mm/s)	1 to 1000
	Displacement (mm)	0.1 to 100
10.0 to 99.9	Acceleration (m/s ²)	0.1 to 100
	Velocity (mm/s)	0.1 to 100
	Displacement (mm)	0.01 to 10

[Usage precautions]

When the measurement mode is set to velocity, the following point should be observed.

The degree by which the inherent noise of the unit (noise generated in the measurement device itself) affects the vibration velocity measurement depends on the sensitivity setting of the piezoelectric accelerometer and the range setting of the unit. Under the following conditions listed below the inherent noise reaches maximum.

Measurement mode: Velocity

Sensitivity and range setting:

Sensitivity setting 0.100 to 0.250, range setting 10 (minimum range)

Sensitivity setting 1.00 to 2.50, range setting 1 (minimum range)

Sensitivity setting 10.0 to 25.0, range setting 0.1 (minimum range)

HPF : OFF

Under the above conditions, you should increase the range setting by one increment, or set the internal high-pass filter to 10 Hz or higher, in order to reduce the influence of inherent noise.

Bar graph indication

The bar graph indicator has 10 segments.

The vibration waveform is averaged and the resulting value is displayed on the bar graph, using a refresh rate of 100 milliseconds.

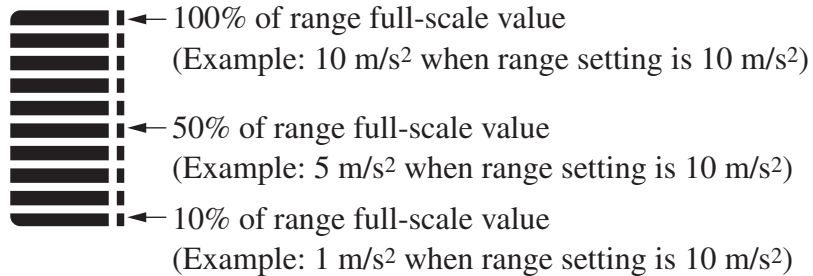

Output signal

The AC OUT connectors on the rear panel provide a signal according to the acceleration/velocity/displacement setting.

The amplitude of the measured vibration waveform can be determined from the selected range and the voltage value.

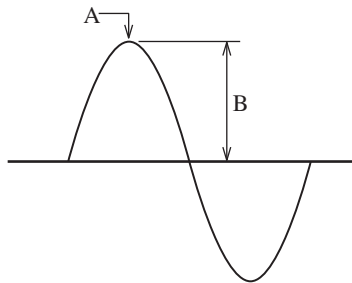

Vibration waveform amplitude at point A = Range × B (unit: V)

Example Range setting is 10 m/s²

Range	Voltage value B	Amplitude
10 m/s ²	5 V	50 m/s ² (Peak)
10 m/s ²	1 V	10 m/s ² (Peak)
10 m/s ²	0.5 V	5 m/s ² (Peak)
10 m/s ²	0.2 V	2 m/s ² (Peak)

Overload indicator LED

At each range setting, measurement is possible up to a point about ten times (+20 dB) higher than the range full-scale point. For example, if the range setting is 10 m/s², measurement is possible up to about 100 m/s² without saturation. Because velocity and displacement are calculated by integration from the acceleration signal, the upper measurement limit for these items is determined by the upper measurement limit for acceleration and the frequency.

Note
When the range setting is 0.03, 0.3, 3, 30, 300, or 3000, the range full-scale values will be 0.0316, 0.3162, 3.162, 31.62, 316.2, or 3162 respectively.

Calibration (CAL) mode

This mode serves for electrical calibration of equipment connected to the AC OUT connectors on the rear panel.

The calibration reference signal available at the AC OUT connectors is an 80 Hz sinusoidal wave signal with a range full-scale value of 1 V (Peak).

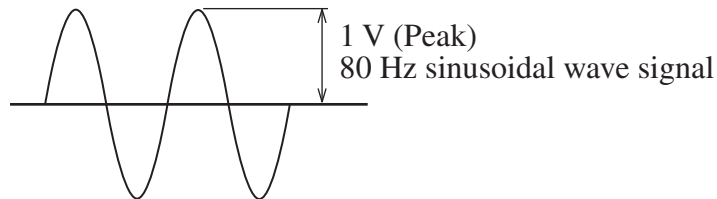

Example When the range setting is 10 m/s², the calibration signal is 1 V = 10 m/s² (Peak).

Calibration procedure

1. At the highest range setting of channel A or channel B, press the RANGE Δ key once more to switch from measurement mode to calibration mode.

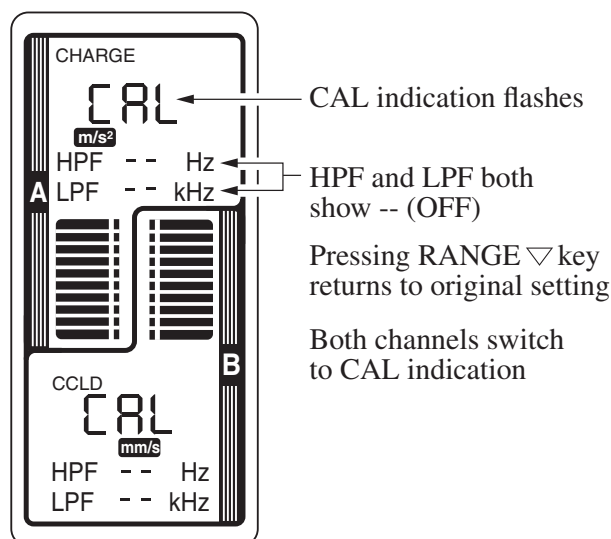

2. In calibration mode, the built-in oscillator is active and supplies a 1 V (Peak) 80 Hz sinusoidal wave signal to the BNC connectors on the rear panel.
3. While the unit is in calibration mode, pressing the RANGE ∇ key for channel A or channel B returns the unit to normal measurement mode.

Note
The calibration mode operates for both channels together.

Performance Characteristics

The response characteristics with 10 Hz high-pass filter and 1 kHz low-pass filter engaged fulfill the frequency response requirements of ISO 2954 for a “Vibration Severity Meter” and of JIS B 0907:1989 for a “Vibration Severity Measurement Device”.

The filter cutoff frequency is defined as the point with a -10% (-1 dB) drop. High-pass filter (HPF) frequency response

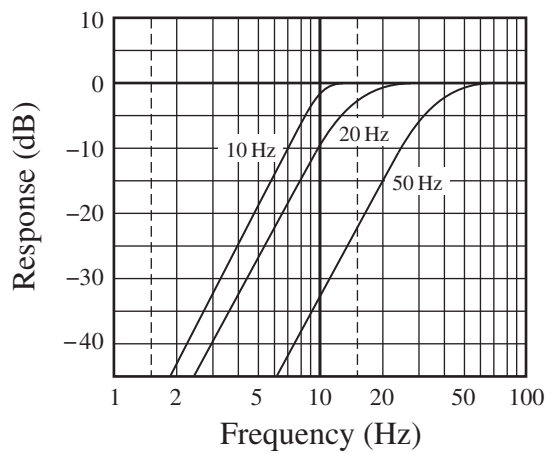

UV-16 HPF Frequency response

Low-pass filter (LPF) frequency response

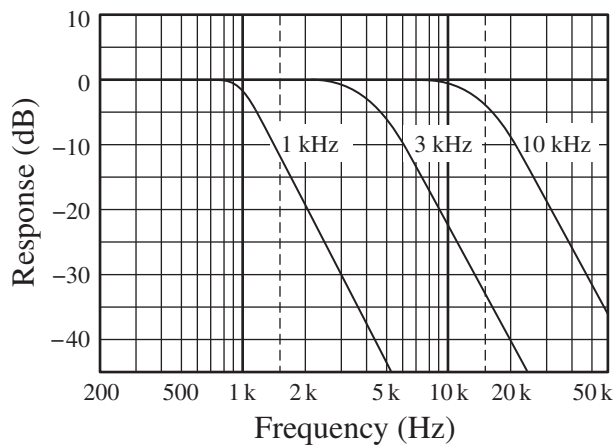

UV-16 LPF Frequency response

Velocity (VEL) and displacement (DISP) frequency response characteristics

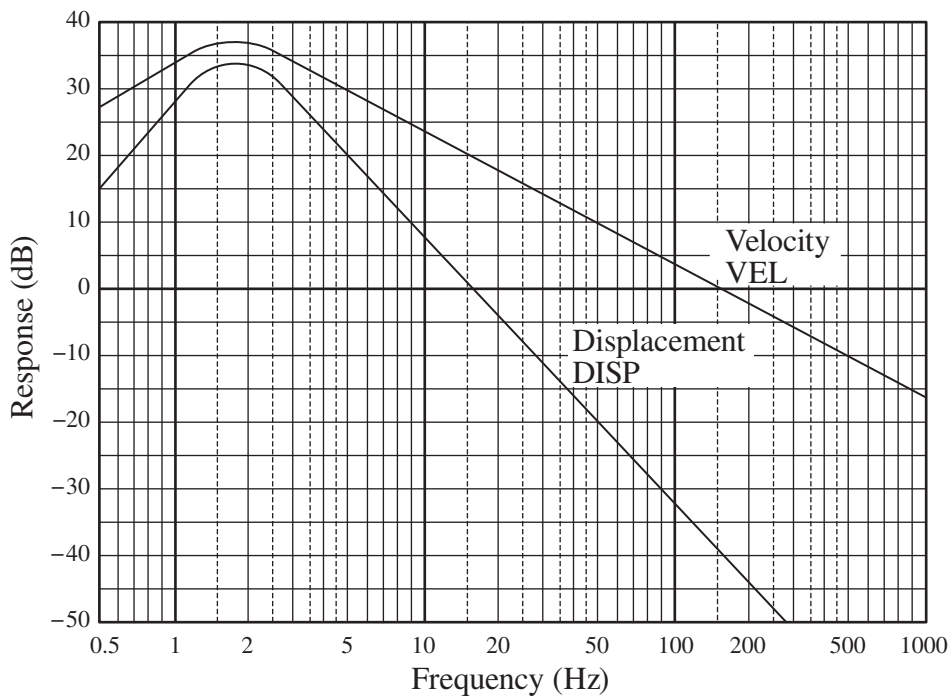

UV-16 velocity (VEL) and displacement (DISP) frequency response characteristics

Specifications

Applicable standards CE marking, UKCA marking, China RoHS

Input

Number of channels 2

Connector type Microdot connectors

Supported accelerometers

Piezoelectric accelerometer

Accelerometer with integrated preamplifier, 24 V 4 mA

Measurement modes and units

Acceleration/velocity/displacement, selectable

ACC (acceleration): m/s^2

VEL (velocity): mm/s

DISP (displacement): mm

Sensitivity setting

Setting range 0.100 to 0.999 in 0.001 steps

1.00 to 9.99 in 0.01 steps

10.0 to 99.9 in 0.1 steps

Units $\mu\text{C}/(\text{m/s}^2)$ (using piezoelectric accelerometer)

$\text{mV}/(\text{m/s}^2)$ (using accelerometer with integrated pre-amplifier)

Range

Seven stages Sensitivity setting determines range.

Sensitivity setting 0.100 to 0.999

ACC (acceleration): 10, 30, 100, 300, 1000, 3000, 10000

VEL (velocity): 10, 30, 100, 300, 1000, 3000, 10000

DISP (displacement): 1, 3, 10, 30, 100, 300, 1000

Sensitivity setting 1.00 to 9.99

ACC (acceleration): 1, 3, 10, 30, 100, 300, 1000

VEL (velocity): 1, 3, 10, 30, 100, 300, 1000

DISP (displacement): 0.1, 0.3, 1, 3, 10, 30, 100

Sensitivity setting 10.0 to 99.9

ACC (acceleration): 0.1, 0.3, 1, 3, 10, 30, 100

VEL (velocity): 0.1, 0.3, 1, 3, 10, 30, 100

DISP (displacement): 0.01, 0.03, 0.1, 0.3, 1, 3, 10

Frequency range

ACC (acceleration): 1 Hz to 15 kHz (AC output tolerance $\pm 5\%$)0.5 Hz to 30 kHz (AC output tolerance $\pm 10\%$)VEL (velocity): 3 Hz to 3 kHz (AC output tolerance $\pm 5\%$)DISP (displacement): 3 Hz to 500 Hz (AC output tolerance $\pm 10\%$)

Filter

HPF: OFF, 10 Hz, 20 Hz, 50 Hz

LPF: 1 kHz, 3 kHz, 10 kHz, OFF

HPF 10 Hz and LPF 1 kHz setting compliant with JIS B 0907:1989 frequency response compensation filter

Display

Segment-type LCD with backlight

Display contents Various settings, bar graph level indication (100 ms cycle)

Alarm indication

2 LED overload indicators (red)

Output

AC output BNC connector $\times 2$ Output impedance 50Ω

Output voltage accuracy (80 Hz full-scale)

ACC (acceleration): 1 V (Peak) $\pm 2\%$ VEL (velocity): 1 V (Peak) $\pm 3\%$ DISP (displacement): 1 V (Peak) $\pm 5\%$ Max. output voltage ± 10 V (Peak) or higherChannel crosstalk -80 dB or lower

(Settings for both channels: sensitivity 5.00, range 100, acceleration, input signal 10 kHz)

Calibration output signal

Sinusoidal wave 80 Hz $\pm 5\%$, output signal 1 V (Peak) $\pm 2\%$

Inherent noise	Input capacitance 1000 pF, sensitivity 5.00, piezoelectric accelerometer, HPF OFF, LPF OFF, lowest range setting ACC (acceleration): 0.01 m/s ² (RMS) or less VEL (velocity): 0.1 mm/s (RMS) or less DISP (displacement): 0.0015 mm (RMS) or less
Power supply	9 V to 15 V DC Power consumption Approx. 70 mA (Using piezoelectric accelerometer: FRONT CHARGE setting, 12 V DC) Approx. 110 mA (Using accelerometer with integrated preamplifier : FRONT CCLD setting, 12 V DC) Suitable AC adapters NC-99 series (up to 16 units) 40 VA or less when using sixteen UV-16 units (100 V AC) Battery Unit BP-17 (up to 3 units when operating on battery power) Automotive 12 V battery CC-82 (Car battery adapter)
Resume function	Memorizes all settings at power-off and restores the settings at the next power-on.
Temperature and humidity conditions for use	-10°C to +50°C, max. 90% RH (no condensation)
Dimensions, Mass	150 mm (H) × 36 mm (W) × 179 mm (D) (without protruding parts) Approx. 500 g

Supplied accessories

Instruction manual	1
Link plate	1
Inspection certificate	1

Optional accessories

AC adapter	NC-99 series (up to 16 units)
Battery Unit	BP-17
BNC-BNC cable	NC-39A
Piezoelectric accelerometer	Various
Connection cable	Various
Rack Mounting Base	CF-27
Car battery adapter	CC-82

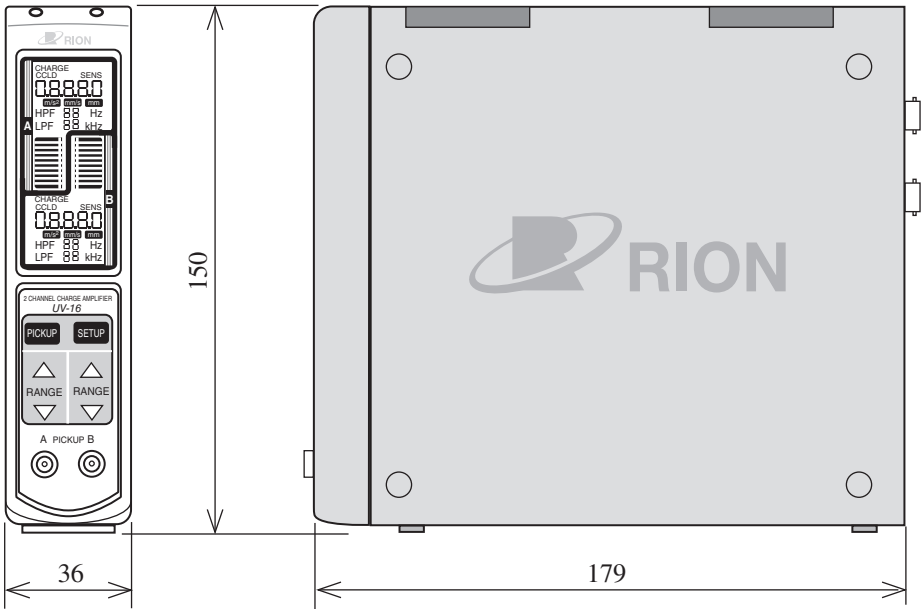

Unit: mm

Dimensional Drawing

Rack Mounting Base

The dimensional drawing of the optional accessory, rack mounting base CF-27 is shown below.

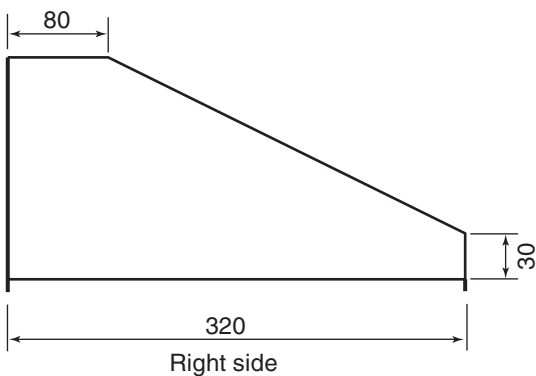
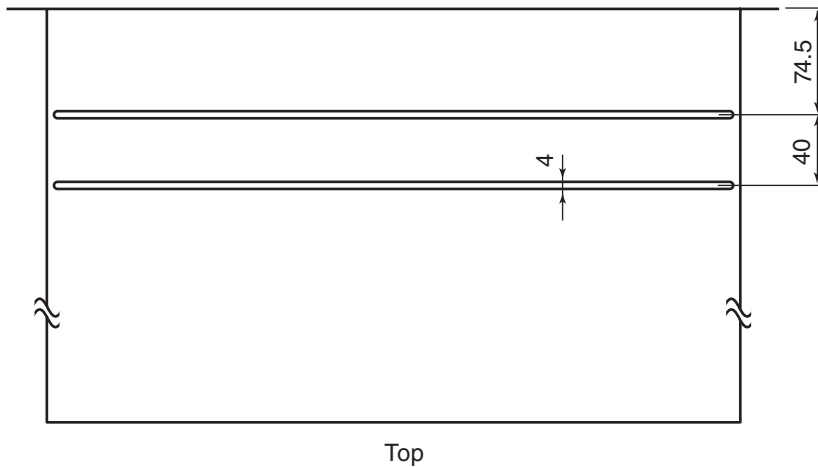
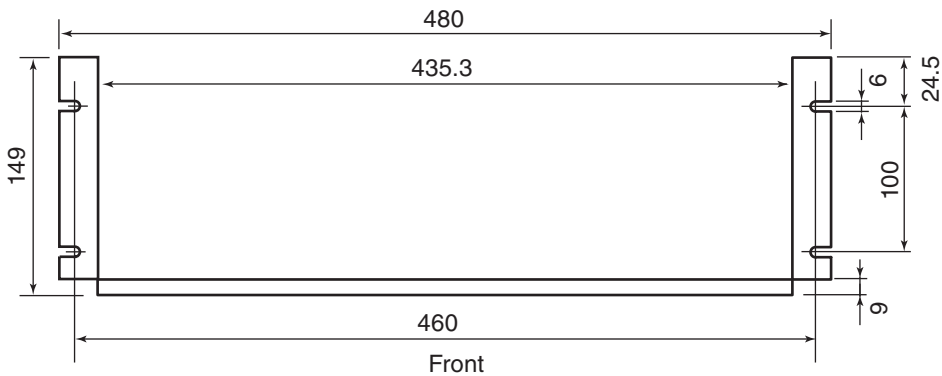

Board thickness: 1.6

Material: SPCC (cold rolled sheets)
with rust prevention treatment

Painting color: Munsell N 7.5

Unit: mm

Reference Material

Lower measurement limit

The lower measurement limit is determined by the inherent noise of the equipment.

The table below gives the inherent noise of the UV-16 [as measured by connecting an equivalent capacitance of 1000 pF, using a sensitivity setting of 5.00 pC/(m/s²)], and representative inherent noise figures for a range of accelerometers.

Input	Acceleration/velocity/displacement	HPF/LPF	Inherent noise (20°C 40%RH)
1000 pF dummy	Acceleration	OFF/OFF	0.01 m/s ² (RMS)
	Velocity	OFF/OFF	0.1 mm/s (RMS)
	Displacement	OFF/OFF	0.0015 mm (RMS)
PV-87	Acceleration	OFF/OFF	0.0013 m/s ² (RMS)
	Velocity	OFF/OFF	0.013 mm/s (RMS)
	Displacement	OFF/OFF	0.00025 mm (RMS)
PV-85	Acceleration	OFF/OFF	0.008 m/s ² (RMS)
	Velocity	OFF/OFF	0.08 mm/s (RMS)
	Displacement	OFF/OFF	0.0013 mm (RMS)
PV-90B	Acceleration	OFF/OFF	0.25 m/s ² (RMS)
	Velocity	OFF/OFF	2.5 mm/s (RMS)
	Displacement	OFF/OFF	0.05 mm (RMS)
PV-91C *1	Acceleration	OFF/OFF	0.02 m/s ² (RMS)
	Velocity	OFF/OFF	0.48 mm/s (RMS)
	Displacement	OFF/OFF	0.029 mm (RMS)
PV-91CH *2	Acceleration	OFF/OFF	0.007 m/s ² (RMS)
	Velocity	OFF/OFF	0.133 mm/s (RMS)
	Displacement	OFF/OFF	0.0067 mm (RMS)

Measurement conditions: Temperature 20°C, unit powered by Battery Unit BP-17

*1 PV-91C Inherent noise standard value :
0.02 m/s² (TYP), 0.04 m/s² (MAX.), 1 Hz to 20 kHz.

*2 PV-91CH Inherent noise standard value :
0.007 m/s² (TYP), 0.009 m/s² (MAX.), 1 Hz to 15 kHz.

Maintenance parts

If parts such as link hook, cover plate, or screws were lost by mistake, contact the supplier to obtain replacements.

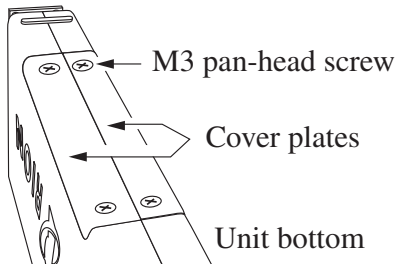

Part name: Cover plate
Part number: UV-16-008

Part name: M3 pan-head screw
Rion designation: KS 3 × 10
Conventional market designation:
pan-head screw M3 × 10
Screw length 10 mm

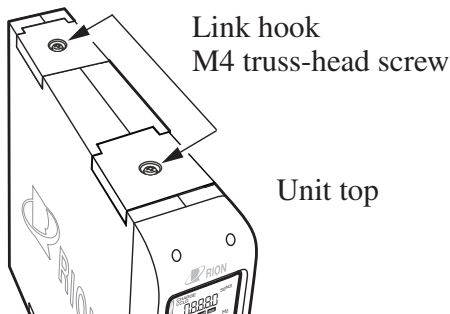

Part name: Link hook
Part number: UV-16-004

Part name: M4 truss-head screw
Rion designation: KT 4 × 8
Conventional market designation:
truss-head screw M4 × 8
Screw length 8 mm

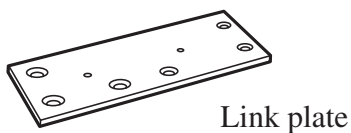

Part name: Link plate
Part number: UV-16-007

