

# **INSTRUCTION MANUAL**

Vibration Meter Unit

## **UV-15**



3-20-41 Higashimotomachi, Kokubunji, Tokyo 185-8533, Japan

<https://www.rion.co.jp/english/>



## Organization of this manual

This manual describes the features, operation, and other aspects of the Vibration Meter Unit UV-15. If the unit is used together with other equipment to configure a measurement system, consult the documentation of all other components as well. The section starting on page iii contains important information about safety. Be sure to read and observe these precautions in full.

This manual contains the following sections.

### **Outline**

Gives basic information about the unit and contains a block diagram.

### **Names of Parts and Functions**

Briefly identifies and explains the front panel controls, rear panel connectors and all other parts of the unit.

### **Linking**

Explains how to configure multiple units as a system.

### **Power Supply Connection**

Explains how to make connections for powering the unit.

### **Accelerometer Selection and Connection**

Explains the types of accelerometers that can be used, how to connect them, and how to set them up for measurement.

### **Output Connections**

Explains how to use the output connectors on the rear panel.

### **Operation Modes**

Explains the operation modes necessary for measurement, including input mode, measurement mode, and calibration mode (Output CAL).

## Performance Characteristics

Contains charts that show the characteristics of the high-pass filter and low-pass filter as well as velocity (VEL) and displacement (DISP) frequency response characteristics.

## Specifications

Lists the technical specifications of the unit.

## Reference Material

Provides an explanation of output signal delay. Maintenance parts are also listed in this section.

- \* Company names and product names mentioned in this manual are usually trademarks or registered trademarks of their respective owners.

# FOR SAFETY

In this manual, important safety instructions are specially marked as shown below. To prevent the risk of death or injury to persons and severe damage to the unit or peripheral equipment, make sure that all instructions are fully understood and observed.

<b>⚠ WARNING</b>	● —————	Disregarding instructions printed here incurs the risk of death or severe injury to persons.

<b>⚠ Caution</b>	● —————	Disregarding instructions printed here incurs the risk of injury to persons and/or damage to peripheral equipment.

<b>Important</b>	● —————	Disregarding instructions printed here incurs the risk of damage to the product.



<b>Note</b>	● —————	Additional information about using the unit. (These notes do not directly affect safety.)

This product may cause interference if used in residential areas. Such use must be avoided unless the user takes special measures to reduce electromagnetic emissions to prevent interference to the reception of radio and television broadcasts.



The product described in this manual is in conformity with the following standards;

Electrical equipment for measurement control and laboratory use.

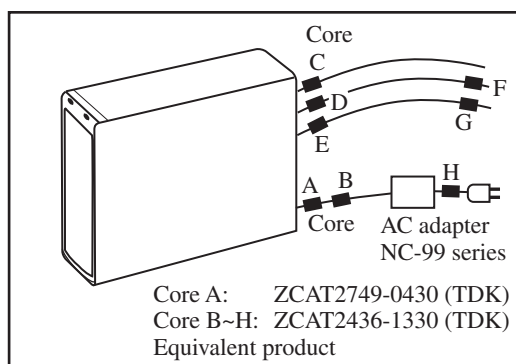

RION Co., Ltd.

3-20-41 Higashimotomachi, Kokubunji, Tokyo 185-8533, Japan

# Precautions

- Operate the unit only as described in this manual.
- Do not disassemble the unit or attempt internal alterations.
- Observe the following precautions before using the unit:
  - Make sure that all connections are properly and safely established.
  - Make sure that the unit is operating normally.
- The permissible ambient temperature range for operation of the unit is  $-10^{\circ}\text{C}$  to  $+50^{\circ}\text{C}$ . Relative humidity must be 90% or below.
- The power cord used to connect the optional AC adapter to an AC outlet is a 100 V AC cord for domestic use in Japan, which is compliant with Japanese laws and electrical safety standards. Do not use this power cord outside Japan or with any voltage other than 100 V AC. Otherwise, RION cannot guarantee the safety of the equipment. Use a power cable that is compliant with the laws and electrical safety standards of your location.
- If you notice any sign of a problem during use, disconnect the AC adapter or battery unit, and contact your supplier.
- Do not use or store the unit in locations which
  - may be subject to strong magnetic fields or strong radiation, or
  - may be subject to high levels of dust or splashes of water, or
  - may be subject to gases or air with high salt or sulphur content, or are in the vicinity of stored chemicals, or
  - may be subject to high temperature, humidity, or to direct sunlight, or
  - may be subject vibrations or shock.
- Always switch off the power after using the unit.
- When disconnecting cables, always hold the plug or connector and do not pull the cable.
- Use only the specified AC adapter or other specified power source.
- This is a precision device. Take care not to drop the unit and protect it from shocks.

- The LCD panel of the unit can easily become scratched. Do not tap the panel with a pointed object such as a pencil, screwdriver, etc.
- In case of malfunction, do not attempt any repairs. Note the condition of the unit clearly and contact the supplier.
- When disposing of the unit, follow national and local regulations regarding waste disposal.



# Contents

FOR SAFETY.....	iii
Precautions.....	v
Outline .....	1
Names of Parts and Functions .....	4
Front panel.....	4
Rear panel.....	6
LCD panel .....	7
Operation panel .....	9
Top panel .....	11
Bottom panel .....	11
Linking .....	12
Linking procedure .....	12
Removing the cable from the link connector.....	17
Linking with Battery Unit BP-17 .....	18
Linking with Interface Unit UV-22.....	19
Using a single UV-15 unit .....	20
Power Supply Connection.....	21
Using an AC adapter.....	22
Using the Battery Unit BP-17 .....	23
Accelerometer Selection and Connection .....	25
Accelerometer connection.....	26
INPUT (PREAMP) connector wiring diagram.....	27
Accelerometer mounting .....	28
Output Connections.....	30

Operation Modes.....	31
Input setup mode .....	31
TEDS communication mode.....	34
Setting the ID number .....	35
Measurement setup mode.....	36
Calibration mode (OUTPUT CAL) .....	38
Measurement mode.....	39
Measurement range .....	41
Frequency range .....	41
Measurement upper limit.....	41
Measurement lower limit.....	42
Check mode .....	45
Using the Interface Unit UV-22 (option) .....	46
Restoring the factory default settings .....	48
Performance Characteristics.....	49
Specifications .....	51
Rack Mounting Base .....	58
Reference Material .....	59
Delay of output signal .....	59
User Filter.....	60
Maintenance parts .....	62

# Outline

The UV-15 is a single-channel vibration meter unit with a wide measurement range. It supports connection of piezoelectric accelerometers, accelerometers with integrated preamplifier (24 V DC, 4 mA power supplied), TEDS compliant accelerometers with integrated preamplifier, and accelerometers connected via the Preamplifier VP-26A. The chassis of up to 16 units can be linked to create a multi-channel configuration.

Two types of input connectors are provided (Microdot and 7-pin), and the unit is equipped with a backlight LCD panel, alarm LEDs, operation keys, AC and DC output connectors (BNC), DC IN jack, and link connector.

The following accessories are available as options, allowing the configuration of advanced measurement systems suited to various requirements.

- Sound level Meter Unit UN-14  
Single-channel sound level meter unit designed for connection of a measurement preamplifier microphone.  
In combination with the UV-15, a multi-channel sound and vibration level measurement system can be configured.
- AC adaptor NC-99 series  
AC adaptor supplies the UV-15 with the DC power.  
It also can supply linked multiple unit with the DC power.
- Battery Unit BP-17  
Designed to hold eight IEC R14 (size C) batteries, this unit can be linked to the UN-14 and/or UV-15 to provide power.  
The power switch on the front panel of the BP-17 can be used to switch the entire system on and off.

- Interface Unit UV-22

Linking the UV-22 allows connection to a computer for controlling the sound and vibration level measurement system and for transfer of measurement data.

Both USB and Ethernet connections are supported.

# UV-15 Block Diagram

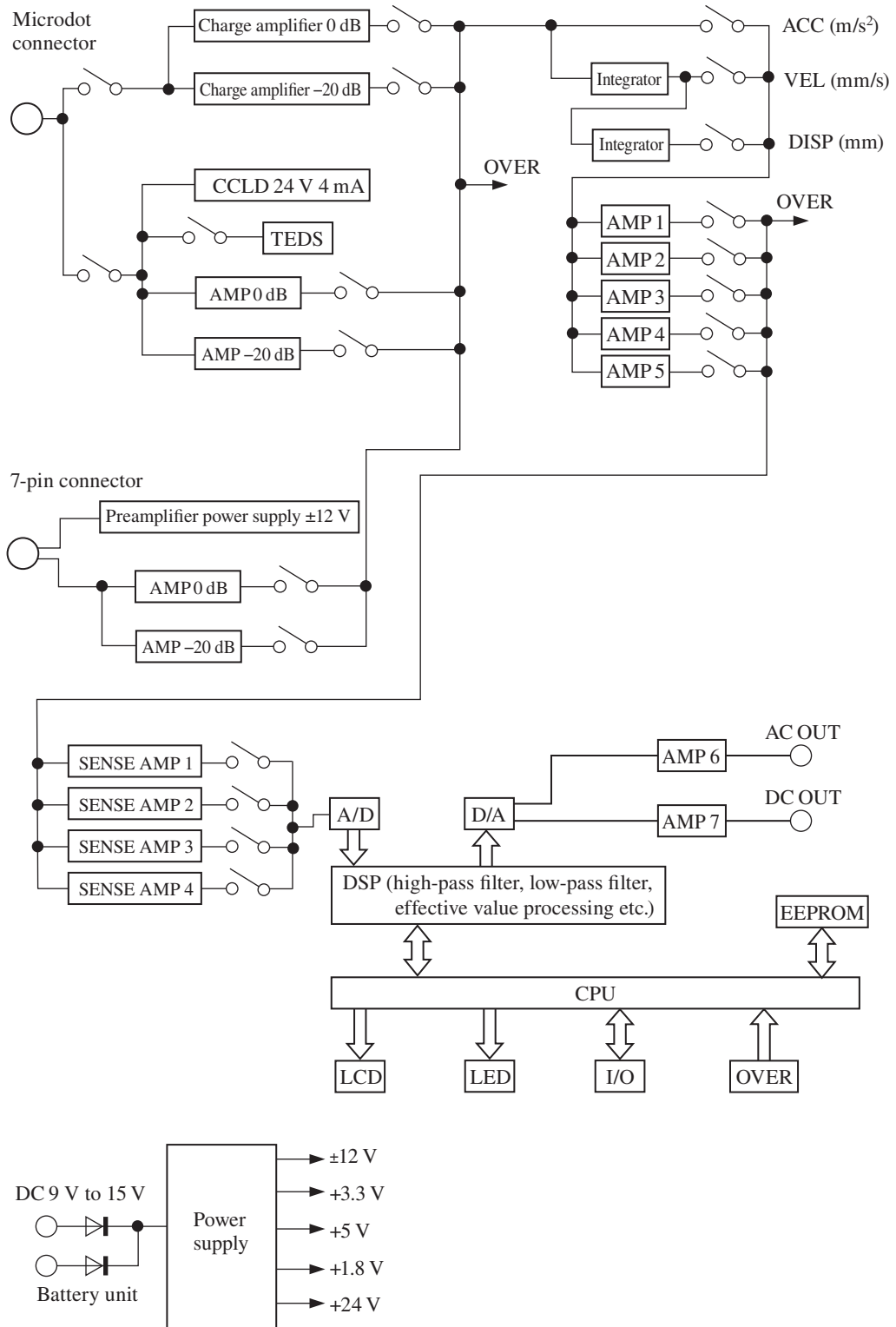

# Names of Parts and Functions

## Front panel

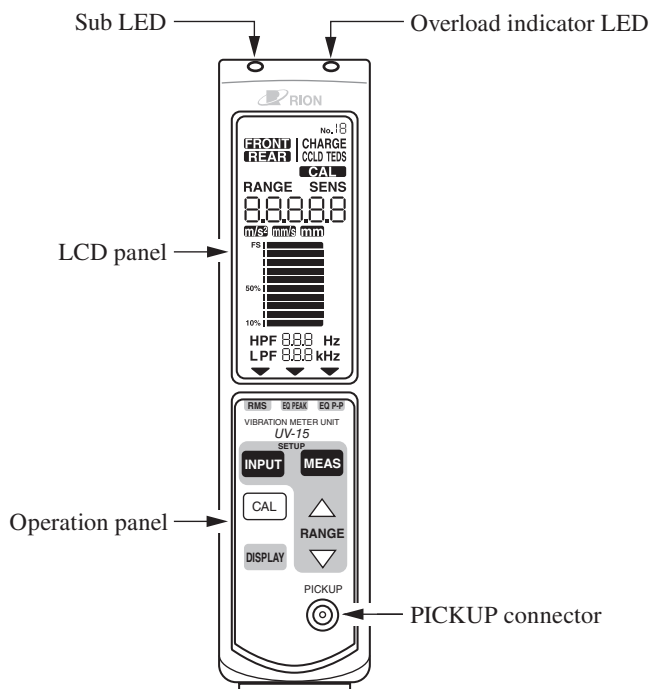

### Sub LED

Lights up in green when a control command from the Interface Unit UV-22 has been received normally and when the Master/Slave function is used.

### Overload indicator LED

Lights up in red when saturation occurs in the internal signal processing circuitry. In such a case, correct measurement is not possible.

### PICKUP connector

Serves for connection of the accelerometer, accelerometer with integrated preamplifier, or TEDS compliant accelerometer with integrated preamplifier.

## Operation panel

Control keys for measurement mode (range selection, display switching etc.) are located here.

## LCD panel

Shows setup information, a bar graph display, numeric display etc.

When the unit is powered from batteries using the Battery Unit BP-17, the display backlight is activated for 10 seconds when any key is pressed.

When the unit is powered from an AC adapter, the display backlight is always on.

## Rear panel

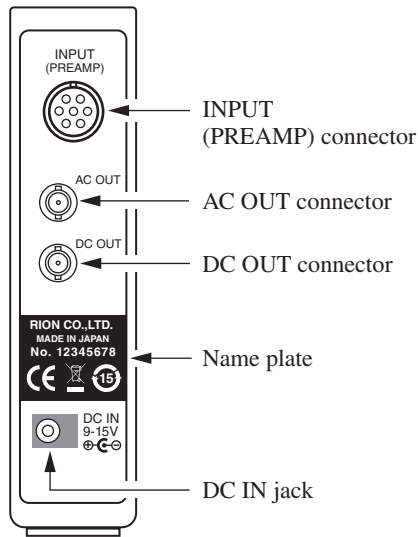

### INPUT (PREAMP) connector

This connector is designed for connection of a piezoelectric accelerometer via the Preamplifier VP-26A.

### AC OUT connector

Supplies an AC output signal equivalent to the input signal.

### DC OUT connector

Supplies a DC output signal equivalent to the input signal.

### Name plate

Shows the serial number and other information about the unit.

### DC IN jack

Serves for connection of the optional AC adapter or an external DC source.



## LCD panel

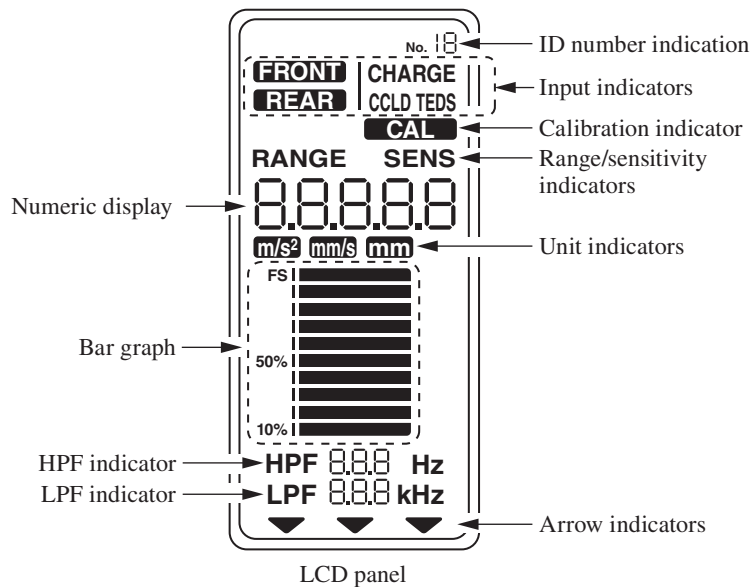

### ID number indication

Serves to identify the unit in a multi-channel configuration. The number display range is 1 to 16.

### Input indicators

The input selection is shown here.

- **FRONT CHARGE:** Piezoelectric accelerometer
- **FRONT CCLD:** Accelerometer with integrated preamplifier
- **FRONT CCLD TEDS:** TEDS compliant accelerometer with integrated preamplifier
- **REAR:** Preamplifier VP-26A connected

### Calibration (CAL) indicator

This indicator blinks when you press the CAL key. The AC OUT and DC OUT connectors on the rear panel supply a calibration signal for calibration of external equipment.

### Range/sensitivity (RANGE/SENS) indicators

When the numeric display shows the current range, the RANGE indicator is on. When the readout shows the sensitivity, the SENS indicator is on. When the numeric display shows the measurement value, both indicators are off.

## Unit indicators

Show the measurement unit for the currently selected measurement mode.

- Acceleration (ACC):  $\text{m/s}^2$
- Velocity (VEL):  $\text{mm/s}$
- Displacement (DISP):  $\text{mm}$

During sensitivity indication, no unit is shown.

## Arrow indicators

Below these arrows are labels for RMS, EQ PEAK, and EQ P-P indication characteristics. The arrow for the currently selected characteristic is visible.

## LPF indicator

Shows the selected low-pass filter setting.

## HPF indicator

Shows the selected high-pass filter setting.

## Bar graph

Shows the level of the signal as a bar graph indication.

## Numeric display

Shows the measurement value, range, sensitivity, and error information.

When the range is changed during measurement value display, the new range setting is shown for about 10 seconds.

## Operation panel

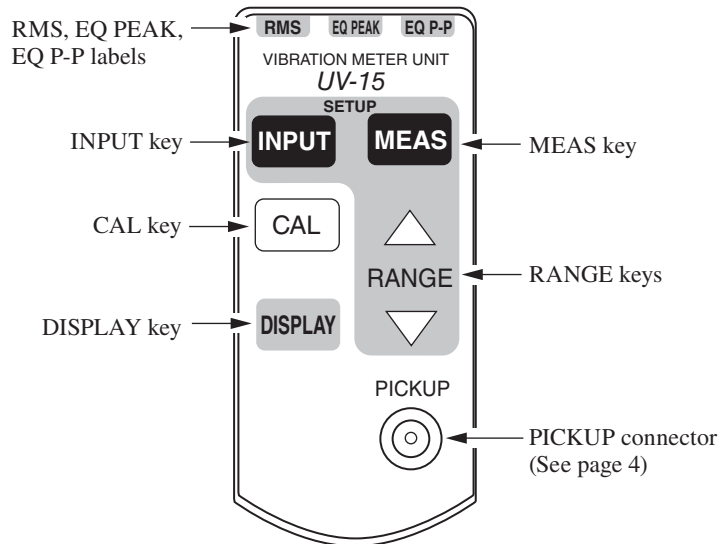

### MEAS key

Serves to select the following modes.

Measurement mode setting

Acceleration (ACC):  $m/s^2$

Velocity (VEL):  $mm/s$

Displacement (DISP):  $mm$

Display characteristics setting

RMS

EQ PEAK

EQ P-P

HPF (high-pass filter) setting

LPF (low-pass filter) setting

### RANGE keys

During measurement, these keys serve to select the range. In the setup mode, the keys serve to change a setting.

## DISPLAY key

Serves to switch the numeric display between range indication and measurement value indication.

## CAL key

Pressing this key causes the AC OUT and DC OUT connectors on the rear panel to supply a calibration signal for calibration of external equipment.

## INPUT key

Serves to make the following settings.

Input selection: FRONT CHARGE/FRONT CCLD/FRONT CCLD TEDS/  
REAR

Sensitivity selection:

0.100 to 0.999, 1.00 to 9.99, 10.0 to 99.9

ID number: 1 to 16

## RMS, EQ PEAK, EQ P-P labels

The arrow indication above the display characteristics selected with the MEAS key is visible.

## Top panel

The top panel of the unit has two hooks which can be used to join multiple units together.

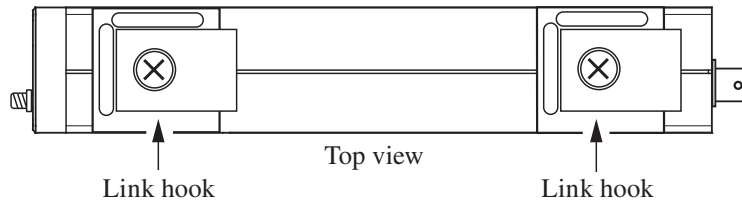

## Bottom panel

Removing the cover plates on the bottom of the unit gives access to a connector that is used to supply power when linking multiple units.

Use the supplied link plate to join multiple units.

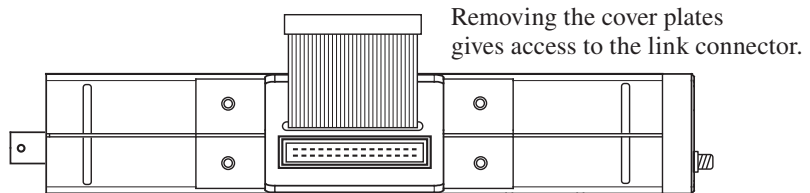
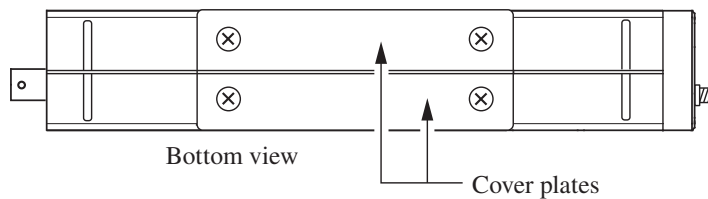

# Linking

Multiple UV-15 units can be linked to form a multi-channel system.

The maximum number of units that can be linked is 16. The Sound level Meter Unit UN-14, Battery Unit BP-17, and Interface Unit UV-22 can also be used.

When using the Battery Unit BP-17 to power the units, the maximum number of units that can be linked is three.

Required tool: 1 Phillips screwdriver (JIS B 4633:1998, type H, No. 2)

## Important

### Precautions for linking units

- Make sure that power is OFF before starting:
  - Disconnect AC adapter.
  - When using Battery Unit BP-17: Remove batteries
- Do not use any screws other than the ones supplied with the product.
- Do not insert any objects (pieces of metal, pencil lead, etc.) into the unit.
- Use only the specified screwdriver (Phillips screwdriver, JIS B 4633:1998, type H, No. 2). Otherwise the cross-shaped slots on the screw heads may be damaged.

## Linking procedure

1. Remove the 4 screws holding the cover plates on the bottom of the unit, and remove the cover plates.

Put the screws and cover plates in a box or other suitable container, to make sure that you do not lose any parts. The parts will be required later for reassembly.

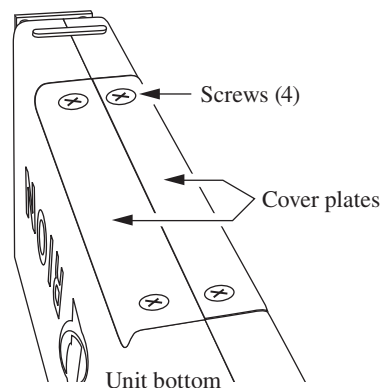

2. Remove the two link hooks on the top panel. Do not remove these hooks for the unit that will be the rightmost unit as seen from the front.

Put the screws and hooks in a box or other suitable container, to make sure that you do not lose any parts. The parts will be required later for reassembly.

Remove link hooks and fastening screws on other units

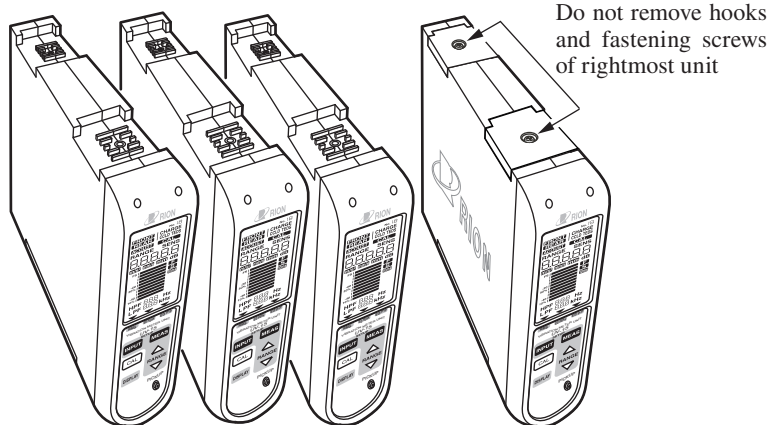

3. For the leftmost unit as seen from the front, roll up the link cable around the connector and push it into the empty space in the unit.

For leftmost unit as seen from the front, roll up link cable along with connector and tag, and push into gap

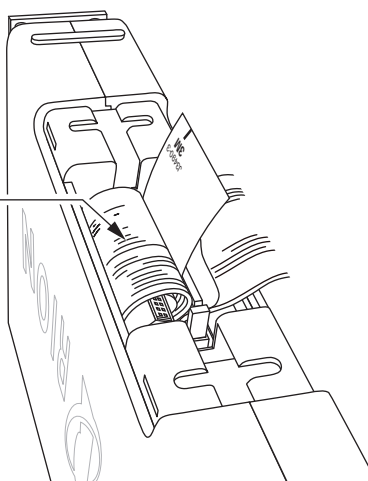

4. Plug the link connector of each unit into the link connector of the next unit.

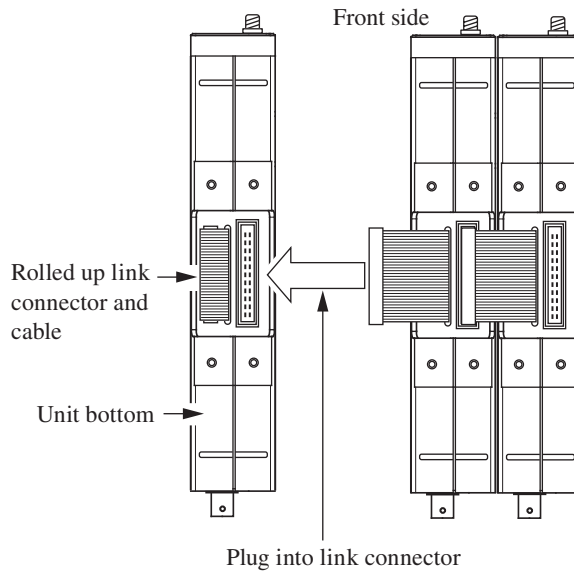

5. After plugging in the link connectors, use the link plates and screws to provisionally join the units as shown below.

Use the screws removed in step 1.

Why not to use other screws:

Too short screws will not properly secure the plate.

Too long screws may damage parts inside the unit.

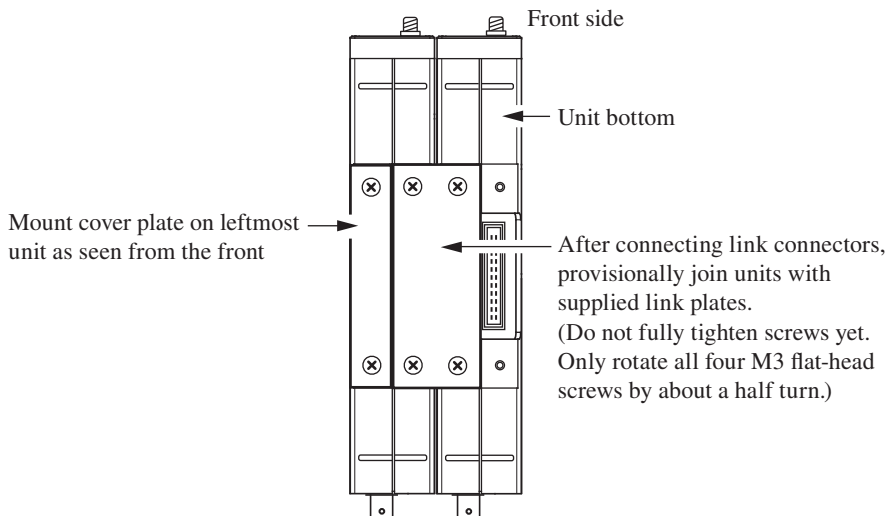



- Attach the link hooks removed in step 2 to the unit tops, so that the units are locked together.

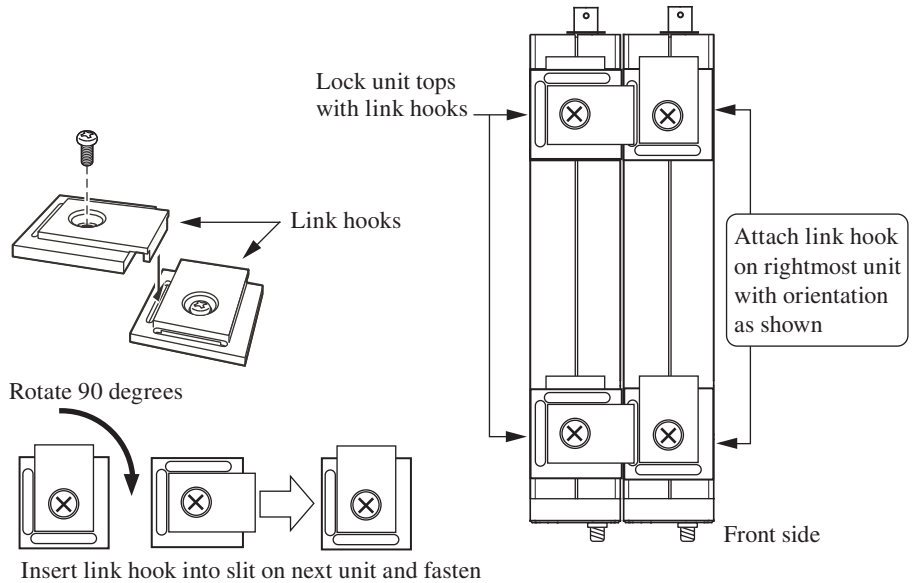

- Make sure that all link connectors are plugged in, and sequentially link the units with the supplied link plates.

Attach the cover plates to the leftmost and rightmost unit.

Securely tighten all flat-head screws.

Use the screws removed in step 1 to fasten the plates.

Why not to use other screws:

Too short screws will not properly secure the plate.

Too long screws may damage parts inside the unit.

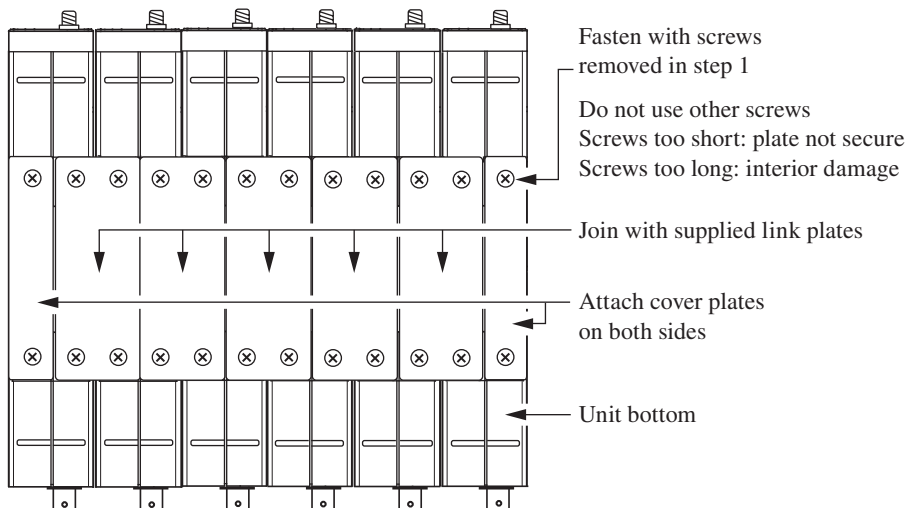

8. Attach the link hooks to the unit tops, so that the units are locked together.

Securely tighten all screws.

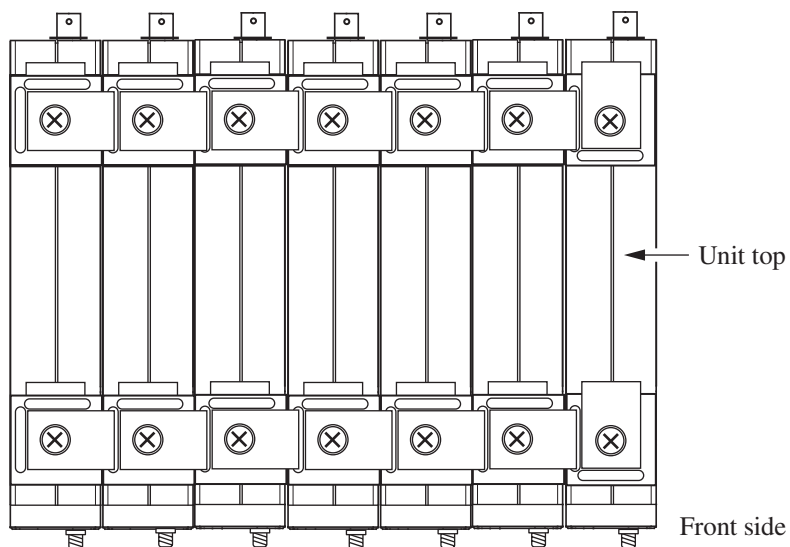

#### Note

If you have lost the original screws, refer to the information about maintenance parts on page 62. Commercially available screws can also be used, provided that exact specifications are met.

Fastening screw for link hook on unit top

Truss-head screw

M4 × 8 (screw length 8 mm)

Fastening screw for link plate on unit bottom

Flat-head screw

M3 × 10 (screw length 10 mm)

Screw types listed according to JIS B 1111.

## Removing the cable from the link connector

To unplug the link connector, grasp the tag as shown in the illustration below and carefully pull the connector out.

### Important

Be sure to grasp the side with the "3M" lettering. If you pull on the other side, the tag may break.

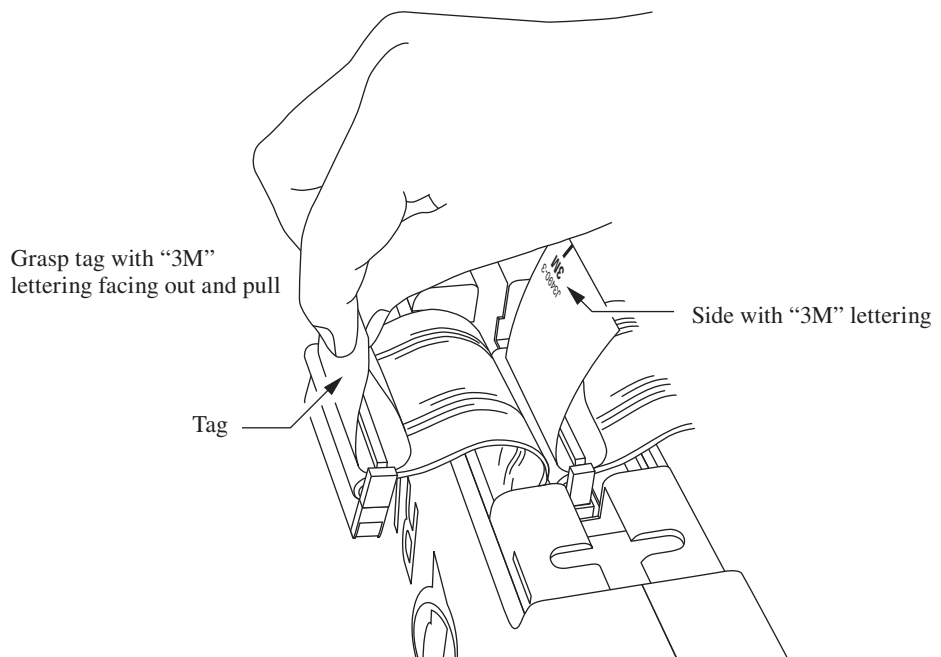

## Linking with Battery Unit BP-17

Install the Battery Unit BP-17 as the rightmost unit of the system as seen from the front.

The cover of the battery compartment in the Battery Unit BP-17 is located on the right side. When installed in this way, the cover can be opened to access the compartment and insert/remove batteries.

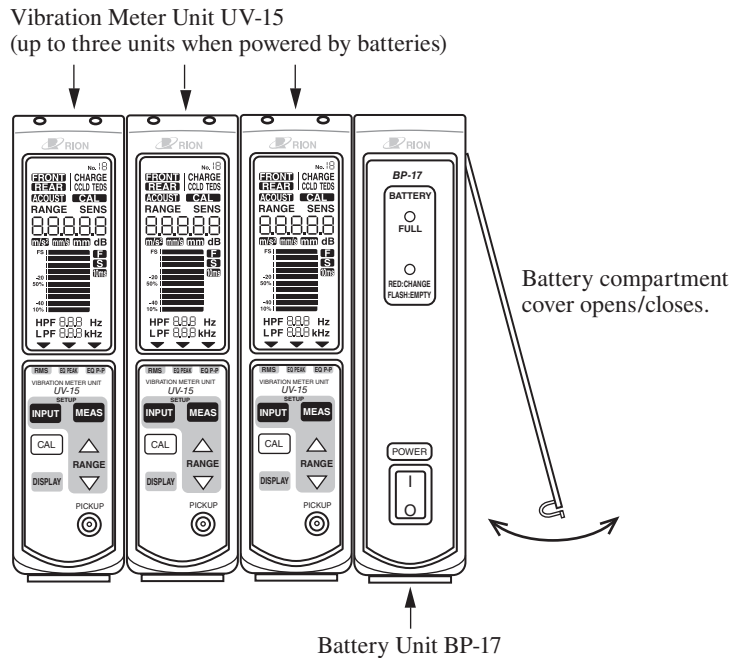

### Note

The AC adapter NC-99 series can power up to 16 linked units.

## Linking with Interface Unit UV-22

Install the Interface Unit UV-22 as the leftmost unit as seen from the front.

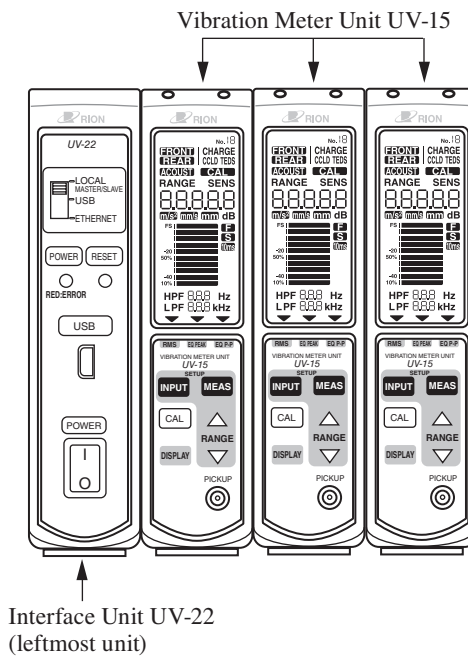

## Using a single UV-15 unit

Attach the supplied link plate to the bottom of the unit as shown below, to stabilize the unit when it is used in a free-standing configuration.

Use the screws removed from the unit.

Why not to use other screws:

Screws too short will not properly secure the plate.

Screws too long may damage parts inside the unit.

1. Remove two screws from the cover plates on the bottom of the unit (the two screws that are nearer to the front side). Refer to the left-side illustration (Fig. 1) below.
2. Use the screws removed in step 1 to fasten the supplied link plate sideways. Refer to the right-side illustration (Fig. 2) below.

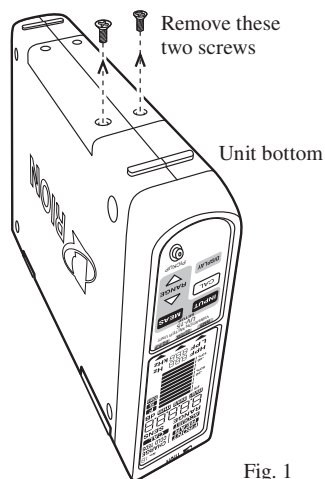

Fig. 1

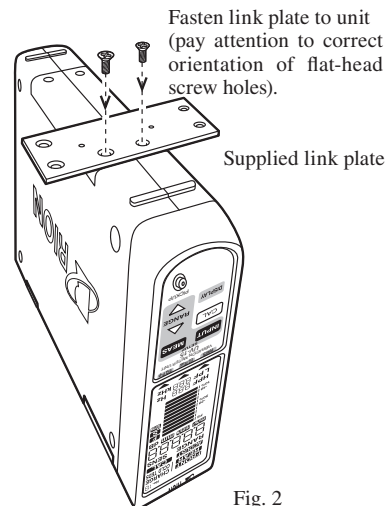
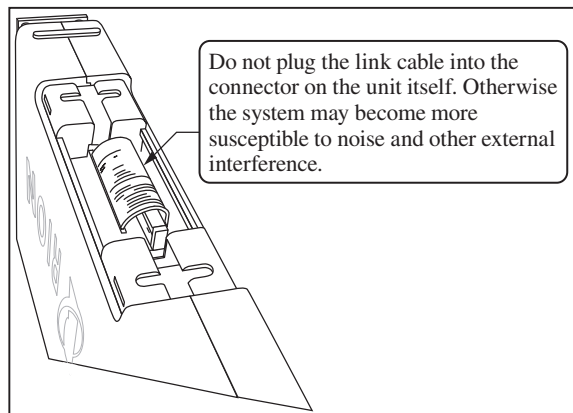
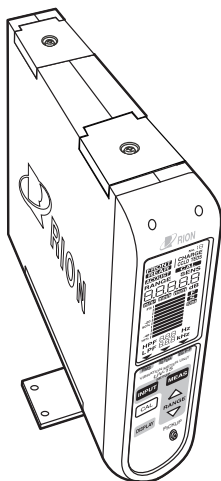

Fig. 2



# Power Supply Connection

The UV-15 can be powered from an AC adapter (option), the Battery Unit BP-17 (option), or a car battery (12 V).

The UV-15 does not have a power switch. It will start to operate when power is supplied.

The Battery Unit BP-17 (option) and Interface Unit UV-22 have a power switch which allows shutting down the system.

## Important

When using multiple units in a linked configuration, make sure that system assembly is fully completed before supplying power.

Power supply limitations		
Power supply type	Max. number of units	
AC adapter (option)	NC-99 series	Up to 16 units
Battery Unit BP-17 (option)	IEC R14 (size C) battery × 8	Up to 3 units

## Note

The display backlight is always on when the unit is powered from an AC adapter. When the unit is powered from batteries using the Battery Unit BP-17, the display backlight is activated for 10 seconds when any key is pressed.

If a system which includes the UV-15 and the Battery Unit BP-17 is to be powered by an AC adapter, be sure to connect the AC adapter to the BP-17.

The UV-15 does not have a power switch. It will start to operate when power is supplied.

## Using an AC adapter

### ⚠ Caution

Be sure to use only a single AC adapter to power a linked system consisting of multiple UV-15 Vibration Meter Units.

### Important

Do not use any AC adapter other than the specified models. Otherwise malfunction and damage may occur.

If no Battery Unit BP-17 or Interface Unit UV-22 is installed in the system, the AC adapter may be connected to any UV-15 unit.

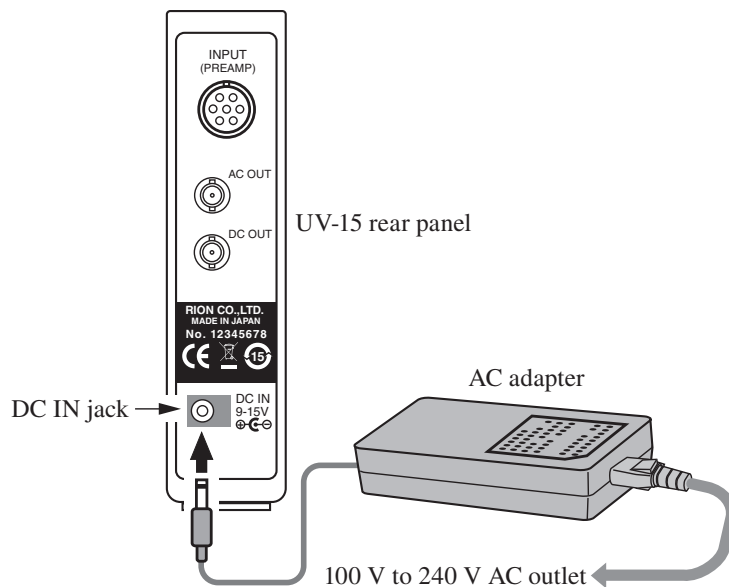

### Note

If the system includes an Interface Unit UV-22 but no Battery Unit BP-17, connect the AC adapter to the UV-22.



## Using the Battery Unit BP-17

### Battery life

Figures for approximate battery life when using the Battery Unit BP-17 are given below.

These figures are for using three UV-15 units.

Manganese batteries	Alkaline batteries
Approx. 2 hours	Approx. 8 hours

Continuous operation at ambient temperature of 25°C, with CHARGE setting\*, normal operation mode

\* With CCLD setting, battery life will be about 30 percent shorter.

For details on how to insert batteries and for other information, please refer to the documentation of the BP-17.

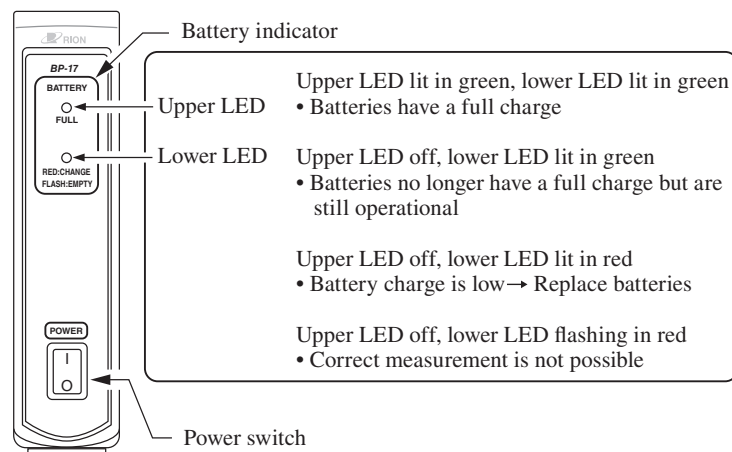

Battery Unit BP-17

### Important

When the upper LED is off and the lower LED lights up in red, you should replace the batteries with a fresh set.

When the lower LED is flashing in red, correct measurement is no longer possible.

Before replacing the batteries, be sure to set the power switch to OFF (press O side).

When inserting batteries, take care not to mix up “+” and “-” polarity.

Always replace all eight batteries together. Using a mixture of old and new batteries or batteries of a different type can lead to malfunction and damage.

When not using the unit, remove the batteries to guard against the risk of damage by leaking battery fluid.

When powering a system from batteries using the BP-17, the maximum number of UV-15 units that can be linked is three.

The Battery Unit BP-17 has a DC IN jack on the rear panel. To power the system from an optional AC adapter, connect the adapter to this jack.

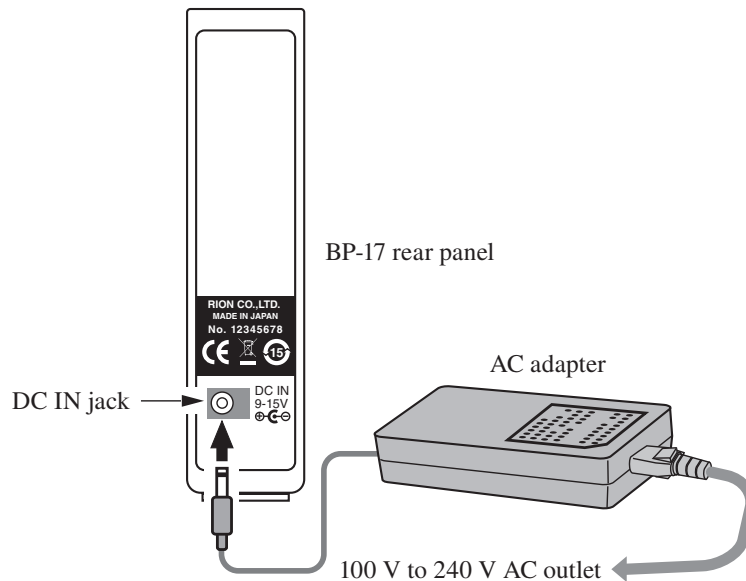

### Important

Do not use any AC adapter other than the specified models. Otherwise malfunction and damage may occur.

If the unit is powered from the AC adapter, continued operation during a power failure is not assured.

### Note

The Battery Unit BP-17 does not have a charging function.

If a system which includes the UV-15 and the Battery Unit BP-17 is to be powered by an AC adapter, be sure to connect the AC adapter to the BP-17.

# Accelerometer Selection and Connection

The following types of accelerometers can be connected to the UV-15.

Accelerometer type	Sensitivity setting range
Piezoelectric accelerometer	0.100 to 99.9 (pC/(m/s <sup>2</sup> ))
Accelerometer with integrated preamplifier	0.100 to 99.9 (mV/(m/s <sup>2</sup> ))
TEDS compliant accelerometer with integrated preamplifier	0.100 to 99.9 (mV/(m/s <sup>2</sup> ))

## Important

Before connecting or disconnecting an accelerometer, be sure to turn off the power supply to the system.

Major piezoelectric accelerometers from Rion (representative values)

	Compact, lightweight	General	High-output	High-temperature	3-axis	
Model	PV-90B	PV-85	PV-87	PV-65	PV-97C	PV-93
Mass (g)	1.2	23	115	26	4.7	30
Typ. sensitivity (pC/(m/s <sup>2</sup> ))	0.18	6.42	40	7.14	0.12	0.831
Frequency range (Hz)*1	1 to 25000	1 to 7000	1 to 3000	1 to 9000	1 to 10000 (X/Y) 1 to 15000 (Z)	1 to 8000 (axis 2) 1 to 4000 (axis 1/axis 3)
Mounting resonance frequency (kHz)*2	70	24	9	25	---	---
Connection cable*3	VP-51L	VP-51A	VP-51A	VP-51B	VP-51L × 3	VP-51C × 3

Major accelerometers with integrated preamplifier from Rion (representative values)

	Compact, lightweight	
Model	PV-91C	PV-91CH
Mass (g)	1.8	3
Typ. sensitivity (mV/(m/s <sup>2</sup> ))*1	1	11
Frequency range (Hz) *2	1 to 20000 *4	1 to 15000 *5
Mounting resonance frequency (kHz) *2	55	50
Connection cable *3	VP-51LC	VP-51LC

\*1 For actual sensitivity values, see sensitivity chart supplied with accelerometer.

\*2 Representative value when mounted on a flat surface using standard mounting method

\*3 Supplied with accelerometer

\*4 At 150°C to 170°C, 1 Hz to 2 Hz (±15%)

\*5 0.6 Hz to 20 kHz, 0.5 Hz to 20 kHz (±30%)

## Accelerometer connection

Connect the accelerometer to the PICKUP connector on the front panel of the UV-15, as shown in the illustration below.

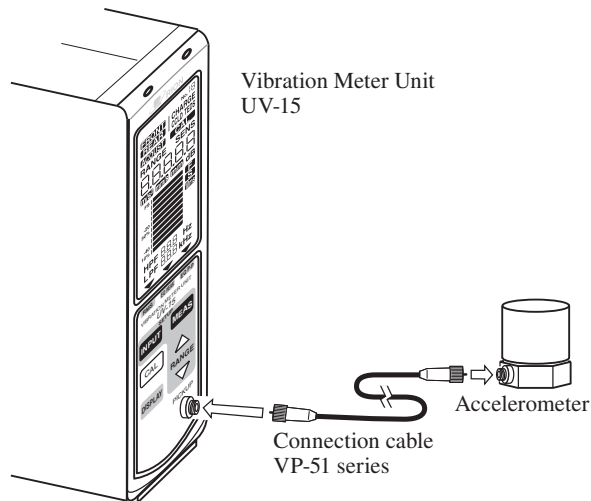

Connect the accelerometer to the INPUT (PREAMP) connector on the rear panel of the UV-15, as shown in the illustration below.

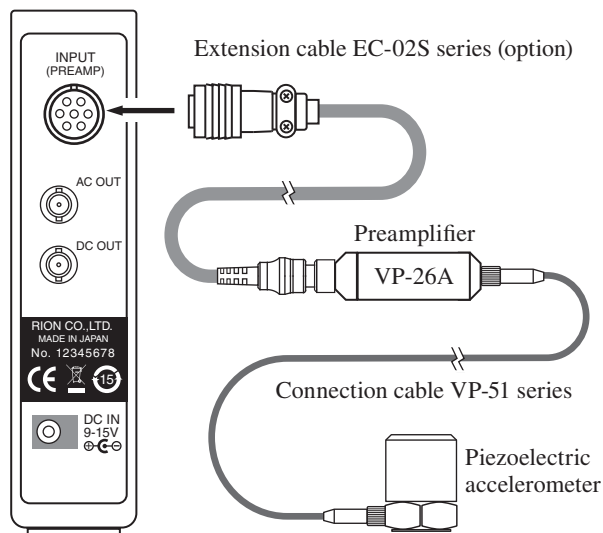

## INPUT (PREAMP) connector wiring diagram

The INPUT (PREAMP) connector is wired as shown below.

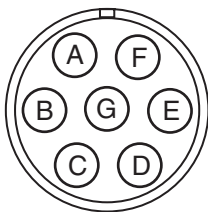

A: +12 V (preamplifier power supply)

B: -12 V (preamplifier power supply)

C: Signal input

D: NC

E: Ground

F: Ground

G: NC

NC: Not connected

(Do not use these pins.)

## Accelerometer mounting

The UV-15 is a vibration meter designed for use with piezoelectric accelerometers or accelerometers with integrated preamplifier. Other types of accelerometers such as electrokinetic accelerometers cannot be used with this product due to different structure. Choose a suitable accelerometer according to the measurement requirements including measurement range, frequency range, and environmental conditions. The accelerometer mounting method has a significant effect on the reliability of measurement data, and it will greatly affect the contact resonance frequency. The advantages and disadvantages of various mounting methods are outlined below. Refer to this information when making your selection.

### Rigid screw mounting

This mounting principle assures optimum frequency response characteristics. The mounting surface should be perfectly smooth, and the screw holes must be drilled in such a way as to assure perfect perpendicularity of the accelerometer.

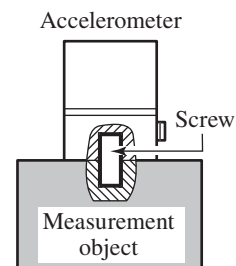

### Insulation attachment mounting

This mounting principle is used when electrical insulation between accelerometer and measurement object is required. The contact resonance frequency will be lower than with rigid screw mounting. Regarding the mounting surface and the screw holes, the same precautions as for rigid screw mounting apply.

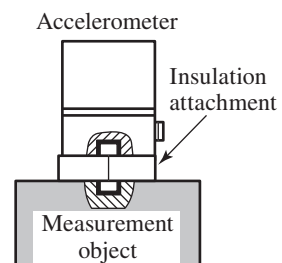

### Magnet attachment mounting

Because the contact resonance frequency will be quite low, this principle is mainly suited for vibration measurements in the medium to low frequency range. The maximum acceleration that can be measured depends on the accelerometer mass.

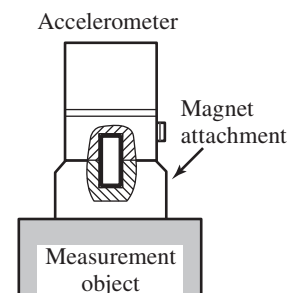

## Rod attachment mounting

Pressing the accelerometer against the measurement object with a rod is the simplest method, but the measurement frequency range would be about several hundred Hz, because the contact resonance frequency will be very low. This method should only be used if none of the other three mounting methods are feasible.

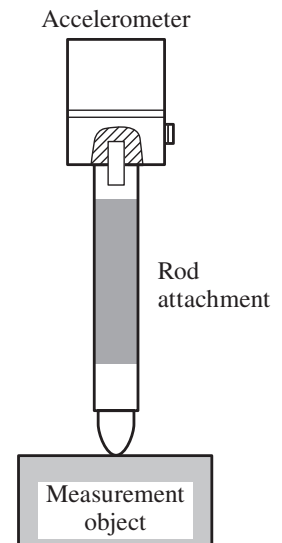

### **⚠ WARNING**

When performing measurements on machinery with exposed rotating parts or drive train parts, proceed with utmost caution to avoid the risk of getting caught in the machinery.

### **Note**

Tighten the M6 screw first on the piezoelectric accelerometer side and then mount the rod attachment.

# Output Connections

The rear panel of the UV-15 provides one AC output connector and one DC output connector. These can be used to supply a signal for example to an oscilloscope for waveform observation, to a data recorder for recording, or to an FFT analyzer for analysis. The calibration signal (see page 38) is also output from these connectors.

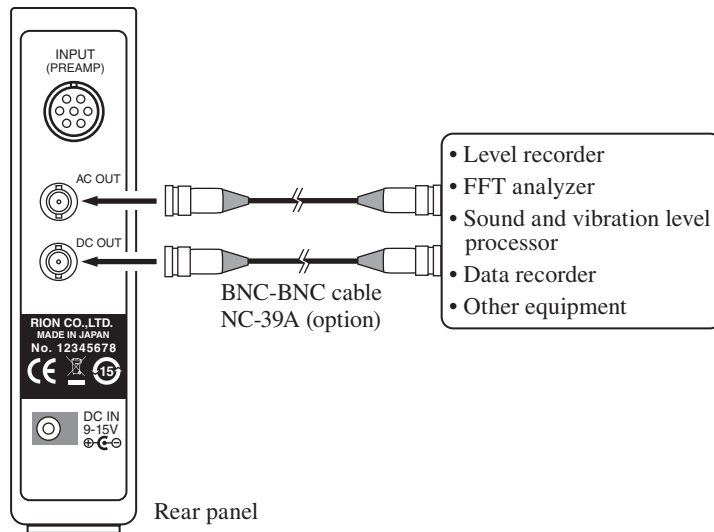

Output type	AC OUT	DC OUT
Connector type	BNC	BNC
Output impedance	Approx. 50 $\Omega$	Approx. 50 $\Omega$
Max. output voltage	Approx. $\pm 10$ V (peak) (no-load condition)	Approx. +10 V (peak) (no-load condition)
Load impedance	10 k $\Omega$ or higher	10 k $\Omega$ or higher



# Operation Modes

The UV-15 has the following operation modes.

Operation mode	Function outline
Input setup mode	Make settings for input (connector, sensitivity) and ID number
TEDS communication mode	Receive sensitivity data and other information from TEDS compliant accelerometer with integrated preamplifier
Measurement setup mode	Make settings for acceleration, velocity, displacement, display characteristics, HPF, and LPF
Calibration mode	Supply CAL signal for calibration of external equipment
UV-22 communication mode	Control UV-15 from connected Interface Unit UV-22
Measurement mode	Make measurements
Check mode	Check the software version of the UV-15

## Input setup mode

This serves to make settings for the connected accelerometer and select an ID number for the UV-15. Be sure to make or check these settings before starting a measurement.

Input setup mode functions	
Item	Settings
Input selection	FRONT CHARGE FRONT CCLD FRONT CCLD TEDS REAR
Sensitivity	0.100 to 0.999 in 0.001 steps 1.00 to 9.99 in 0.01 steps 10.0 to 99.9 in 0.1 steps
ID number	1 to 16

## Setup procedure

1. Pressing the INPUT key in measurement mode activates the input setup mode. The current input setting flashes on the display. In this condition, you can change the setting. Select the appropriate setting for the connected accelerometer and the input that is used.

- **FRONT CHARGE:**  
Piezoelectric accelerometer connected to Microdot connector on front panel
- **FRONT CCLD:**  
Accelerometer with integrated preamplifier connected to Microdot connector on front panel
- **FRONT CCLD TEDS:**  
TEDS compliant accelerometer with integrated preamplifier connected to Microdot connector on front panel
- **REAR:**  
Preamplifier VP-26A connected to 7-pin connector on rear panel

Use the RANGE keys to change and select the setting. The indicator for the selected setting flashes.

When the setting is as required, press the INPUT key.

If FRONT CCLD TEDS was selected, the unit switches to TEDS communication mode when you press the INPUT key. (See page 34.)

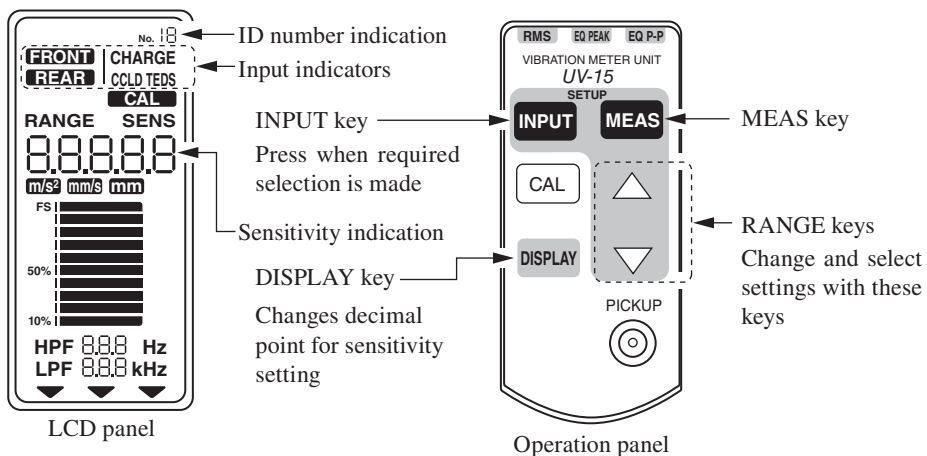

2. When you press the INPUT key, the unit switches to the sensitivity (SENS) setting screen. Use the RANGE keys to make a setting in the range from 0.100 to 0.999, 1.00 to 9.99, or 10.0 to 99.9.

With the DISPLAY key, you can change the decimal point of the sensitivity setting. Holding down a RANGE key changes the numeric value more quickly.

When the setting is as required, press the INPUT key.

3. When you press the INPUT key, the unit switches to the ID number setting screen.

The ID number setting is required for unit identification when multiple UN-14 and UV-15 units are used. For details, see page 35.

The setting range is 1 to 16. Use the RANGE keys to select the number. Holding down a RANGE key changes the numeric value more quickly. For multi-channel configurations, each unit must have a unique ID number.

When the setting is as required, press the INPUT key.

All changed settings will become active. The input setup mode is terminated and the unit switches to measurement mode.

If you press the MEAS key at any point during steps 1 to 3, the settings will become active and the unit switches to measurement mode immediately.

Note
<p>About the ID number</p> <p>When several UN-14 and UV-15 units are used in a multi-channel configuration, the ID number is required for identification.</p> <p>When using the UV-22, make sure that each unit has a unique ID number. If there is more than one unit with the same number, communication with the UV-22 will not function correctly.</p>
<p>Sensitivity setting units</p> <p>pC/(m/s<sup>2</sup>): FRONT CHARGE</p> <p>mV/(m/s<sup>2</sup>): FRONT CCLD FRONT CCLD TEDS REAR</p>

## TEDS communication mode

In this mode, the UV-15 communicates with the TEDS sensor to receive sensitivity information and set the sensitivity accordingly.

TEDS communication can also be carried out in the input setup mode. If a TEDS sensor was used previously, TEDS communication will also be carried out when power is supplied the next time.

### TEDS sensor support

The following types of TEDS sensors are supported.

Template ID: 24, 25

IEEE 1451.4-2000

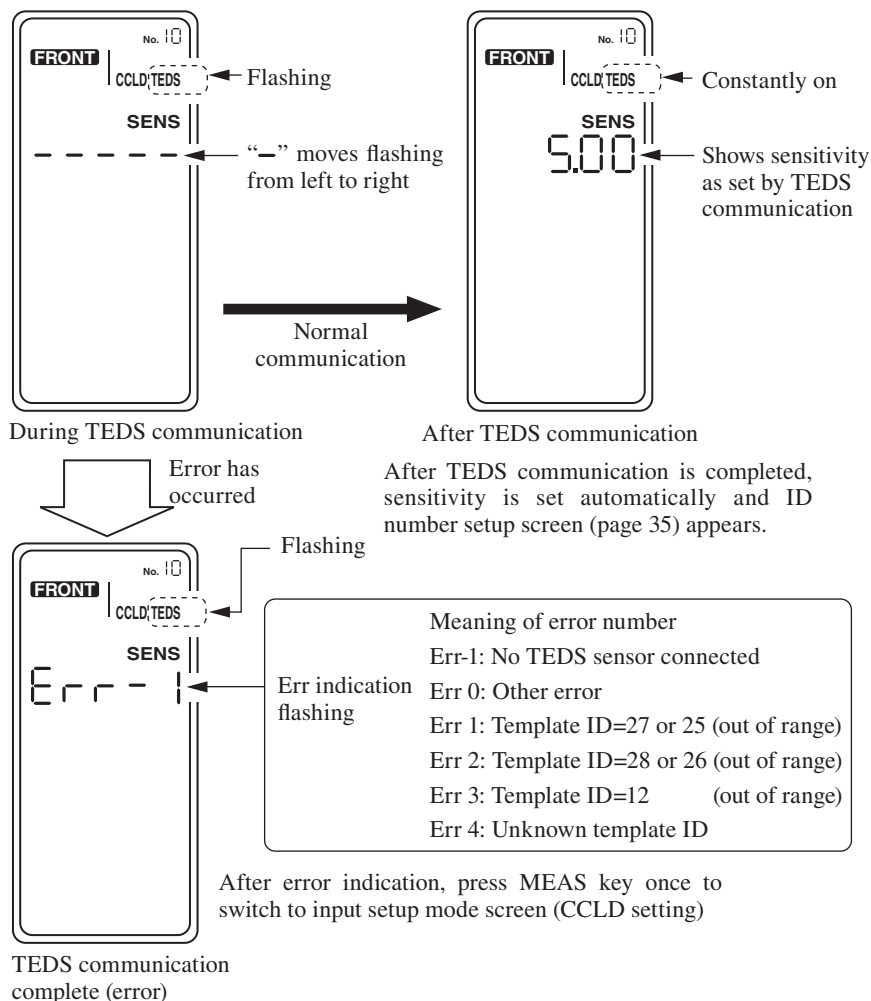

## Setting the ID number

When the UV-15 is used in conjunction with the Interface Unit UV-22, an ID number for the UV-15 must be set first.

To set the ID number, the keys on the operational panel of the respective UV-15 unit must be used.

The default setting for the ID number is No. 1. Be sure to change the setting when there is more than one unit. The setting range is No. 1 to No. 16.

The ID number is used to identify the unit for communication. If there is more than one unit in the same system with the same ID number, correct communication will not be possible.

See illustration below

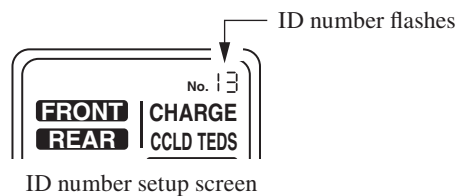

1. When you press the INPUT key on the operation panel of the UV-15 three times in succession, the ID number starts to flash.
2. Use the RANGE keys to set the number. When the setting is complete, press the MEAS key to return to the measurement screen.

Make the setting for each unit individually, so that each unit has a unique ID number.

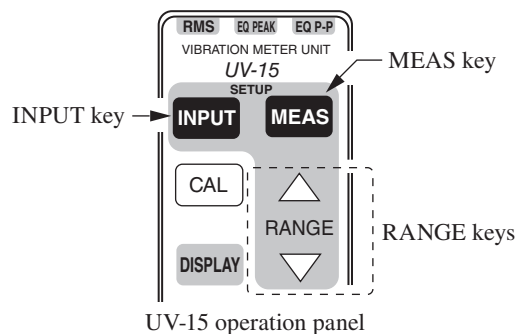

### Note

When a TEDS sensor is connected and the FRONT CCLD TEDS setting is selected, pressing the INPUT key will automatically set the sensitivity. The ID number setup screen then appears.

## Measurement setup mode

This mode serves for selecting the measurement mode (unit), display characteristics, HPF (high-pass filter), and LPF (low-pass filter) settings.

Be sure to make or check these settings before starting a measurement.

Measurement setup mode functions	
	Settings
Select measurement mode (unit)	m/s <sup>2</sup> (Acceleration: ACC), mm/s (Velocity: VEL), mm (Displacement: DISP)
Display characteristics	RMS, EQ PEAK, EQ P-P
HPF setting	OFF (---), 3 Hz, 5 Hz, 10 Hz, 15 Hz, 20 Hz, 30 Hz, 50 Hz, 100 Hz, 150 Hz, 200 Hz
LPF setting	300 Hz, 500 Hz, 1 kHz, 1.5 kHz, 2 kHz, 3 kHz, 5 kHz, 10 kHz, 15 kHz, 20 kHz, OFF (---)

### Setup procedure

1. Pressing the MEAS key in measurement mode activates the measurement setup mode, and allows you to set the measurement mode (unit).

You can change the setting with the RANGE keys.

m/s<sup>2</sup>: Acceleration (ACC)

mm/s: Velocity (VEL)

mm: Displacement (DISP)

When the setting is as required, press the MEAS key.

2. When you press the MEAS key, the display characteristics setup screen appears.

You can change the setting with the RANGE keys.

RMS: Effective value

EQ PEAK: Equivalent peak value ( $\text{RMS} \times \sqrt{2}$ )

EQ P-P: Equivalent peak-to-peak value ( $\text{EQPEAK} \times 2$ )

When the setting is as required, press the MEAS key.

3. When you press the MEAS key, the HPF (high-pass filter) setup screen appears.

You can change the setting with the RANGE keys.

OFF, 3 Hz, 5 Hz, 10 Hz, 15 Hz, 20 Hz, 30 Hz, 50 Hz, 100 Hz, 150 Hz, 200 Hz

The OFF setting is shown as “---”.

When the setting is as required, press the MEAS key.

- When you press the MEAS key, the LPF (low-pass filter) setup screen appears.

You can change the setting with the RANGE keys.

OFF, 300 Hz, 500 Hz, 1 kHz, 1.5 kHz, 2 kHz, 3 kHz, 5 kHz, 10 kHz, 15 kHz, 20 kHz

The OFF setting is shown as “---”.

When the setting is as required, press the MEAS key.

- When you press the MEAS key, the changed settings become active and the setup procedure is completed.

If you press the INPUT key at any point during steps 1 to 4, the settings will become active and the unit switches to measurement mode immediately.

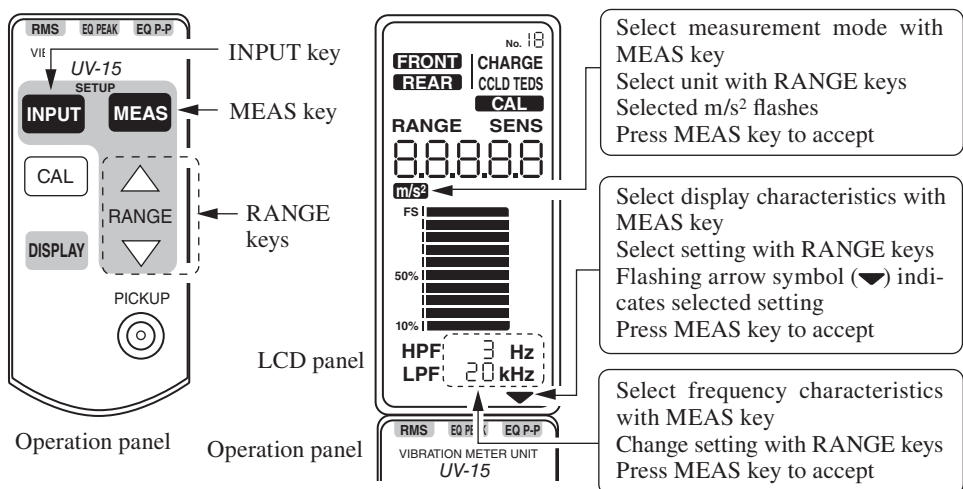

### Note

Range and display characteristics settings are memorized separately for acceleration (ACC), velocity (VEL), and displacement (DISP).

For example, when you change from acceleration (ACC) to velocity (VEL) measurement, the range and display characteristics settings previously selected for velocity (VEL) will be active.

When a user filter setting has been input, the HPF and LPF setup screens will show the user filter frequency as an additional item.

## Calibration mode (OUTPUT CAL)

This mode serves for electrical calibration of external equipment connected to the BNC connectors on the rear panel. A reference signal corresponding to the range full-scale condition is supplied from both connectors.

### Calibration procedure

1. Press the CAL key while the unit is in measurement mode.
2. While the CAL key is being held down, the AC OUT and DC OUT connectors on the rear panel supply a reference signal corresponding to the range full-scale condition.

CAL signal (for calibration of external equipment)

AC OUT: Sinusoidal wave 80 Hz

Display characteristics RMS: 1 V (RMS)  $\pm 2\%$

Display characteristics EQ PEAK:

1 V (PEAK)  $\pm 2\%$

Display characteristics EQ P-P:

1 V (P-P)  $\pm 2\%$

DC OUT:

1 V  $\pm 2\%$

3. Press the CAL key again to return to the measurement mode.

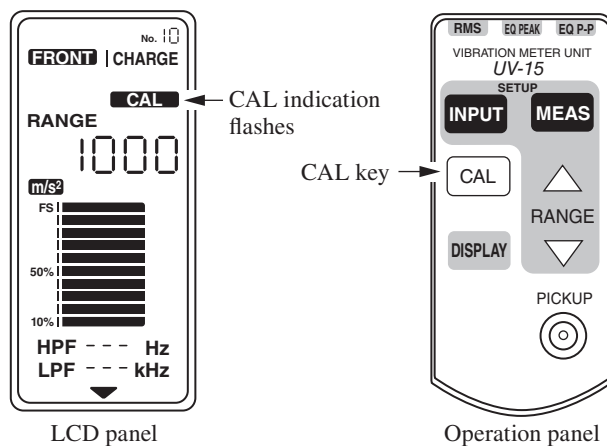

### Note

When the range setting is 0.03, 0.3, 3, 30, 300, or 3000, the range full-scale value is 0.0316, 0.316, 3.16, 31.6, 316, and 3162 respectively.



## Measurement mode

This is the operation mode for performing vibration measurements.

The measurement value corresponding to the vibration magnitude is shown as a numeric indication and as a bar graph on the LCD panel. A corresponding AC signal and DC signal is also output from the respective connectors on the rear panel.

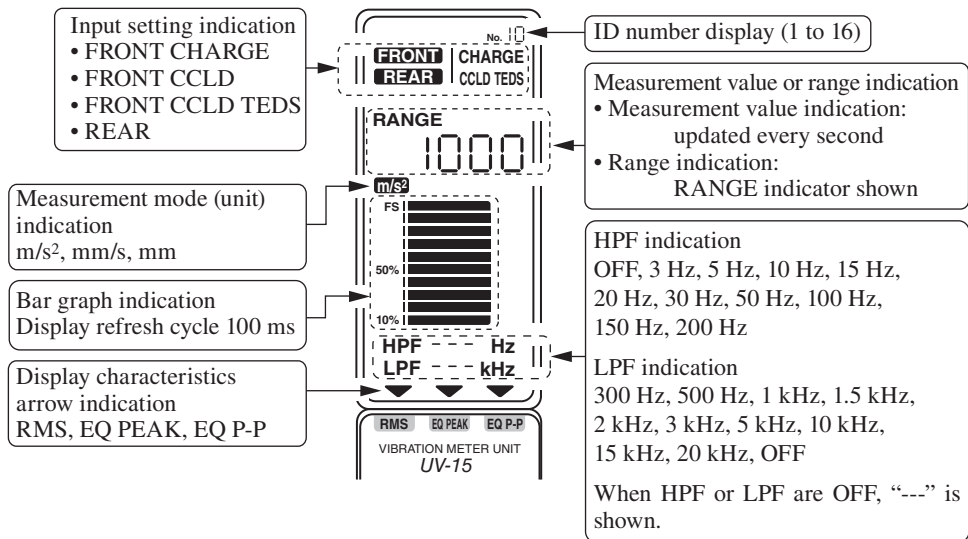

### Bar graph indication

The bar graph indicator has 10 segments.

The refresh cycle of the bar graph is 100 milliseconds.

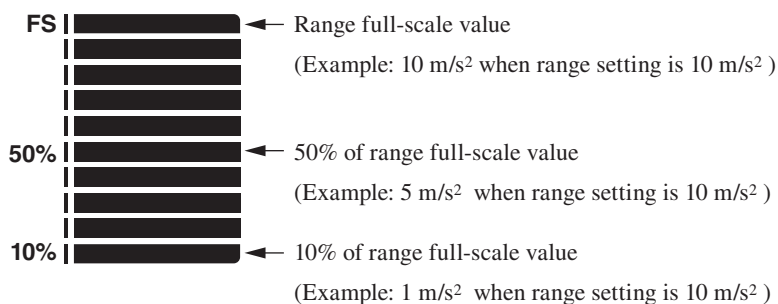

## Changing the range

The RANGE keys can be used to change the range setting.

If the vibration signal is too high for the currently selected range, the internal amplification circuits will saturate, causing the red overload indicator LED to light up. In such a case, correct measurement is not possible, and you should increase the range setting.

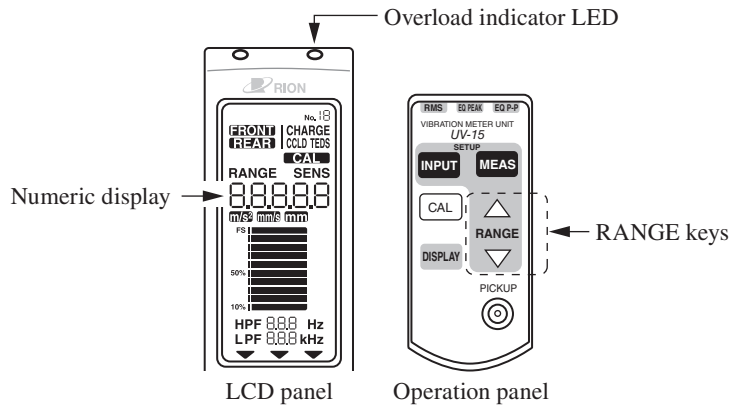

**Note**

If you change the range setting while the numeric display shows the measurement value, the new range setting will be shown for about 10 seconds.

## Range settings

The available range settings are shown below.

### Range settings

Sensitivity	Acceleration/Velocity/Displacement	Range setting
0.100 to 0.999	Acceleration (m/s <sup>2</sup> )	10 to 10000
	Velocity (mm/s)	10 to 10000
	Displacement (mm)	1 to 1000
1.00 to 9.99	Acceleration (m/s <sup>2</sup> )	1 to 1000
	Velocity (mm/s)	1 to 1000
	Displacement (mm)	0.1 to 100
10.0 to 99.9	Acceleration (m/s <sup>2</sup> )	0.1 to 100
	Velocity (mm/s)	0.1 to 100
	Displacement (mm)	0.01 to 10

**Note**

When the range setting is 0.03, 0.3, 3, 30, 300, or 3000, the range full-scale value is 0.0316, 0.316, 3.16, 31.6, 316, and 3162 respectively.

## Measurement range

The measurable frequency range and measurement upper and lower limits depend on the accelerometer in use and the measurement mode.

If the overload indicator LED lights up, the measurement upper limit is being exceeded.

## Frequency range

The frequency range for measurement depends on the measurement mode, as listed below.

Measurement mode and measurement frequency range

Acceleration (m/s <sup>2</sup> )	1 Hz to 15 kHz ( $\pm 5\%$ )
	0.5 Hz to 30 kHz ( $\pm 10\%$ )
Velocity (mm/s)	3 Hz to 3 kHz ( $\pm 5\%$ )
Displacement (mm)	3 Hz to 500 Hz ( $\pm 10\%$ )

## Measurement upper limit

The upper limit for acceleration measurement (maximum input acceleration) depends on the input sensitivity setting.

- When using the PICKUP connector  
Measurement up to 10 times\* the maximum range can be carried out.  
\* Depends to a certain extent on display characteristics.

Sensitivity setting and upper limit for acceleration measurement

Sensitivity setting	Acceleration measurement upper limit
0.1 to 0.999 pC/(m/s <sup>2</sup> )	100000 m/s <sup>2</sup> (PEAK)
1 to 9.99 pC/(m/s <sup>2</sup> )	10000 m/s <sup>2</sup> (PEAK)
10 to 99.9 pC/(m/s <sup>2</sup> )	1000 m/s <sup>2</sup> (PEAK)

- When using the PICKUP connector on the panel  
The maximum input acceleration depends on the connected preamplifier. The maximum input voltage is  $\pm 10$  V (PEAK).
- Upper limit for velocity and displacement  
Because velocity and displacement are calculated by using integration from the acceleration value, the upper measurement limit for these quantities is determined by the upper measurement limit for acceleration and the frequency.

## Measurement lower limit

The lower limit for measurement is determined by the noise level.

This is the level that is indicated when a dummy load of 1000 pF is connected to the PICKUP connector and the sensitivity switch is set to 5.00 pC/(m/s<sup>2</sup>). In order to limit the influence of noise upon the measurement to no more than 1 dB (approx. 10%), the lower limit is set to a point two times higher than the noise level.

Input	Acceleration/Velocity/Displacement	HPF/LPF	Inherent noise (20°C 40% RH)
1000 pF dummy	Acceleration	OFF/OFF	0.01 m/s <sup>2</sup> (RMS)
	Velocity	OFF/OFF	0.1 mm/s (RMS)
	Displacement	OFF/OFF	0.0015 mm (RMS)
PV-87	Acceleration	OFF/OFF	0.0013 m/s <sup>2</sup> (RMS)
	Velocity	OFF/OFF	0.013 mm/s (RMS)
	Displacement	OFF/OFF	0.00025 mm (RMS)
PV-85	Acceleration	OFF/OFF	0.008 m/s <sup>2</sup> (RMS)
	Velocity	OFF/OFF	0.08 mm/s (RMS)
	Displacement	OFF/OFF	0.0013 mm (RMS)
PV-90B	Acceleration	OFF/OFF	0.25 m/s <sup>2</sup> (RMS)
	Velocity	OFF/OFF	2.5 mm/s (RMS)
	Displacement	OFF/OFF	0.05 mm (RMS)
PV-91C *1	Acceleration	OFF/OFF	0.02 m/s <sup>2</sup> (RMS)
	Velocity	OFF/OFF	0.53 mm/s (RMS)
	Displacement	OFF/OFF	0.024 mm (RMS)
PV-91CH *2	Acceleration	OFF/OFF	0.007 m/s <sup>2</sup> (RMS)
	Velocity	OFF/OFF	0.117 mm/s (RMS)
	Displacement	OFF/OFF	0.0068 mm (RMS)

Measurement conditions: temperature 20°C, unit powered from batteries using BP-17

\*1 PV-91C Inherent noise standard value :

0.02 m/s<sup>2</sup> (TYP), 0.04 m/s<sup>2</sup> (MAX.), 1 Hz to 20 kHz.

\*2 PV-91CH Inherent noise standard value :

0.007 m/s<sup>2</sup> (TYP), 0.009 m/s<sup>2</sup> (MAX.), 1 Hz to 15 kHz.

## AC OUT signal

The AC signal supplied at the AC OUT connector on the rear panel corresponds to the selected measurement mode (acceleration/velocity/displacement) and HPF and LPF settings.

The amplitude of the signal can be calculated from the selected range and the voltage value.

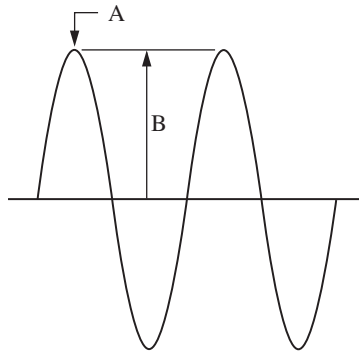

Waveform peak value at point A = B (unit: V) × range full-scale

Example: Range 10, measurement mode m/s<sup>2</sup>

Range	Voltage B	Peak value
10 m/s <sup>2</sup>	10 V	100 m/s <sup>2</sup>
10 m/s <sup>2</sup>	1 V	10 m/s <sup>2</sup>
10 m/s <sup>2</sup>	0.5 V	5 m/s <sup>2</sup>
10 m/s <sup>2</sup>	0.1 V	1 m/s <sup>2</sup>

### Note

When the range setting is 0.03, 0.3, 3, 30, 300, or 3000, the range full-scale value is 0.0316, 0.316, 3.16, 31.6, 316, and 3162 respectively.

## DC OUT signal

The DC signal supplied at the DC OUT connector on the rear panel is obtained by rms conversion of the AC signal with a time constant of 1 second.  
 Range full-scale value: 1 V

The measurement value can be calculated from the selected range and the voltage, according to the diagram below.

Example: Range 100, measurement mode  $m/s^2$

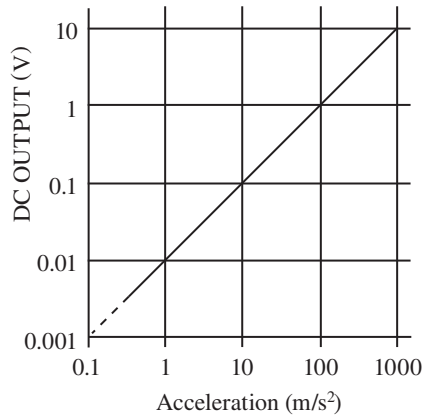

## Overload indicator LED

At each range setting, measurement is possible up to a point about ten times (+20 dB)\* higher than the range full-scale point.

\* Dependent on display characteristics

For example, if the range setting is  $10 m/s^2$ , measurement is possible up to about  $100 m/s^2$  without saturation.

Because velocity and displacement are calculated by integration from the acceleration value, the upper measurement limit for these quantities is determined by the upper measurement limit for acceleration and the frequency. When saturation of the internal circuits occurs, the red overload indicator LED lights up. In this case, correct measurement is not possible.

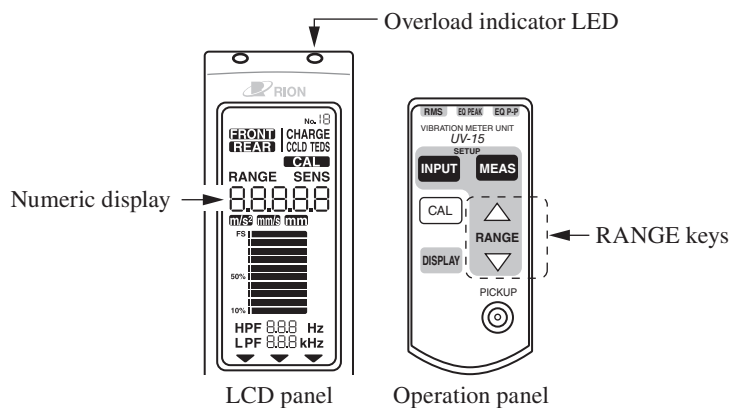

## Check mode

You can check the software version of the UV-15 as follows.

1. Press the CAL key while the unit is in measurement mode.
2. Hold down the RANGE  $\triangle$  key for at least 2 seconds, until the version number is shown on the LCD panel.
3. Press the MEAS key to return to the measurement mode.

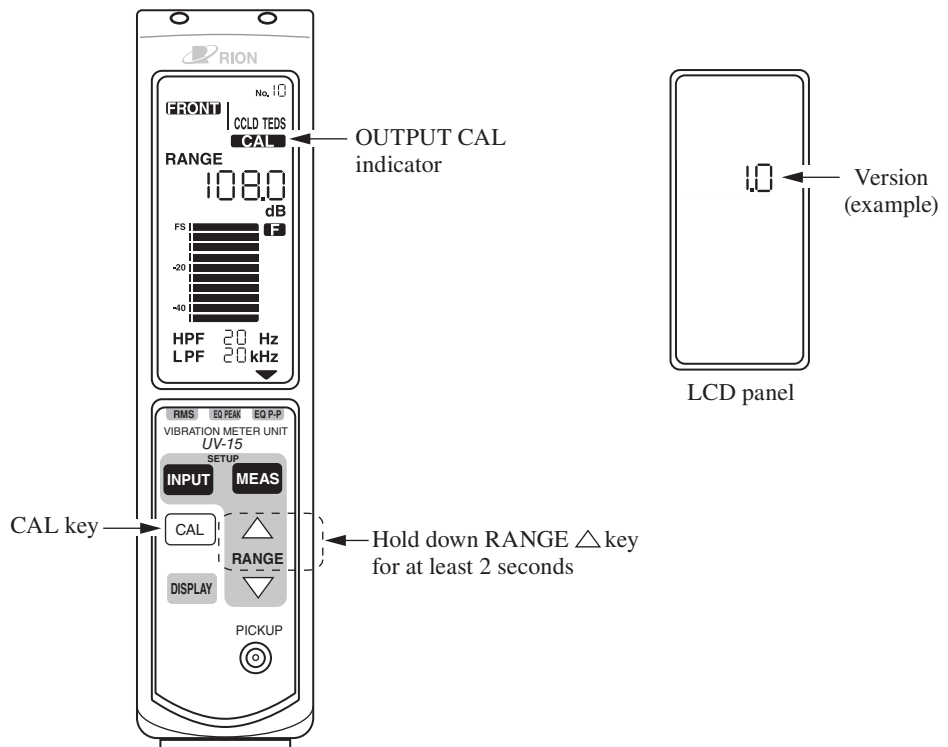

## Using the Interface Unit UV-22 (option)

When the UV-22 is connected, the sound and vibration measurement system can be controlled by sending commands from a computer, and measurement values can be transferred to the computer.

Both USB and Ethernet connections are supported. A Software UV-22Viewer is also supplied to the UV-22.

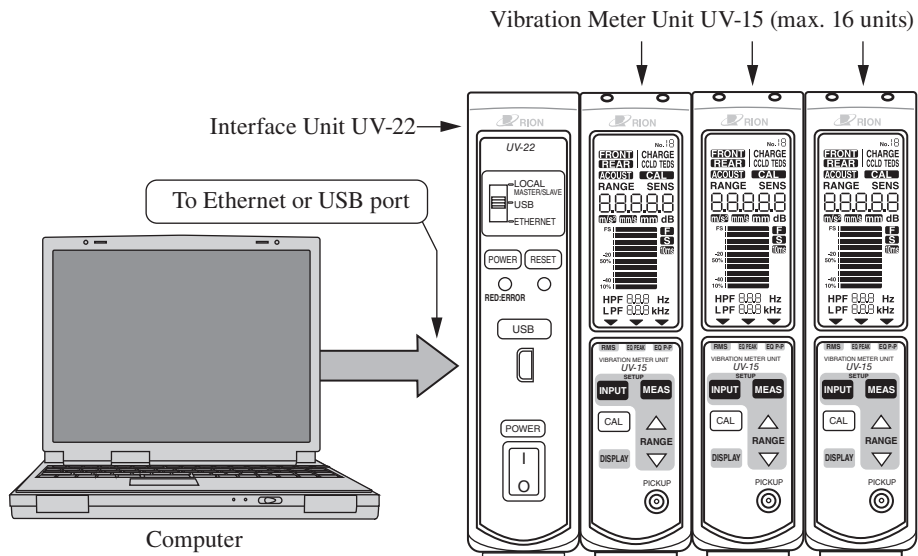

### Main functions with UV-22 connected

- Setup control from computer  
System setup can be performed from a computer, via a USB or Ethernet connection.
  - USB: USB 1.1    One-on-one connection between computer and UV-22
  - Ethernet:        10/100 Base-TX  
One-on-one connection between computer and UV-22
  
- Data transfer to computer  
Measurement data can be sent to a computer, via a USB or Ethernet connection.
  - Measurement data:
    - 100 ms instantaneous value, maximum value, ± peak



- User filter settings

One cutoff frequency as specified below can be added to the HPF and LPF settings.

For information on user filter frequencies, see pages 60 and 61 in the “Reference Material” section.

HPF cutoff frequency (attenuation  $-18$  dB/oct):

Any center frequency from 3.15 Hz to 160 Hz can be specified, in 1/3 octave steps.

LPF cutoff frequency (attenuation  $-18$  dB/oct):

Any center frequency from 315 Hz to 20 kHz can be specified, in 1/3 octave steps.

- Master/Slave function

When not connected to a computer, the settings of multiple units in a system can be changed from one unit using this function. This is useful to make the settings of multiple units identical.

## Restoring the factory default settings

Turning power to the unit on while holding down the MEAS key will clear the resume information and return the unit to the factory default condition.

### Input settings

INPUT:	FRONT CHARGE
Sensitivity:	5.00
ID number:	1
Range:	100
Numeric display:	Numeric indication
Measurement mode (unit):	m/s <sup>2</sup>
Display characteristics:	RMS
HPF:	OFF
LPF:	OFF

# Performance Characteristics

The high-pass filter (HPF) and low-pass filter (LPF) frequency response characteristics are shown below.

The filter cutoff frequency is defined as the point with a  $-10\%$  ( $-1$  dB) drop.

## HPF (high-pass filter) characteristics

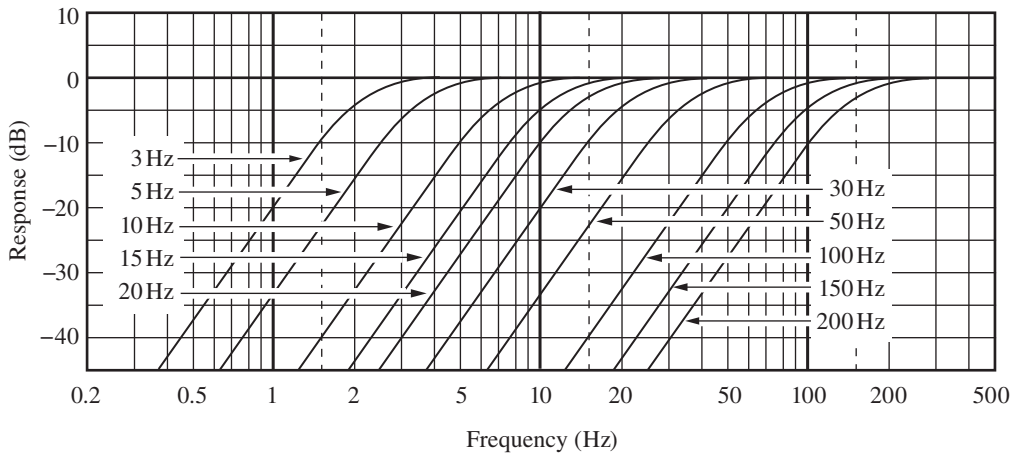

UV-15 HPF frequency response characteristics

## LPF (low-pass filter) characteristics

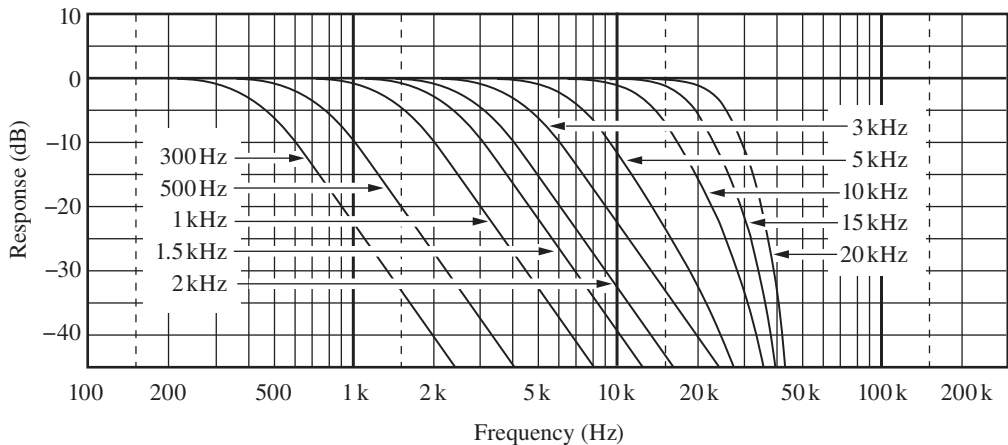

UV-15 LPF frequency response characteristics

### VEL (velocity) and DISP (displacement) characteristics

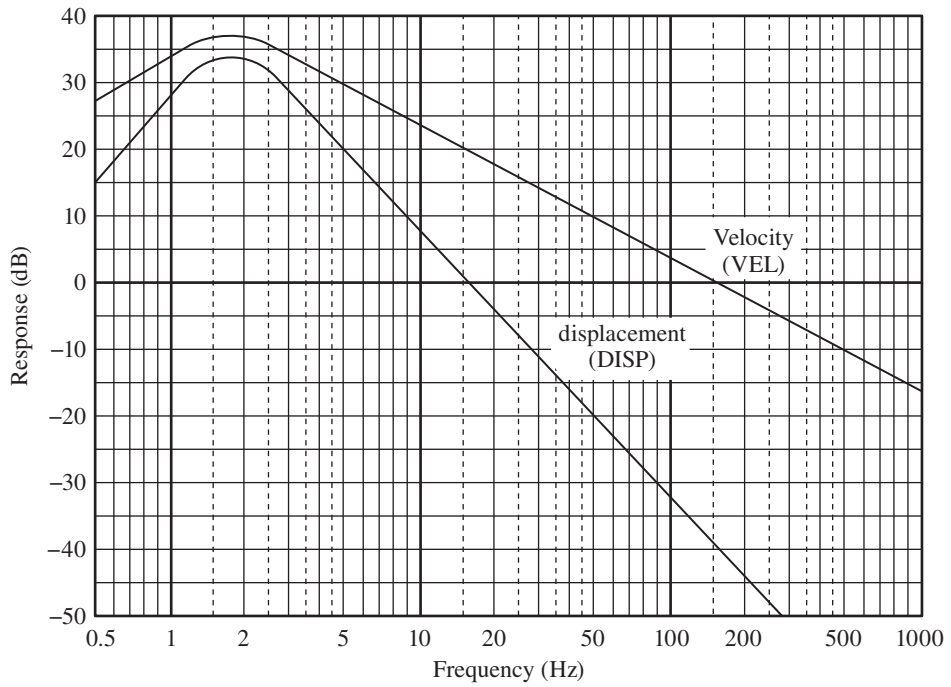

Velocity (VEL) and displacement (DISP) frequency response characteristics

# Specifications

Applicable standards CE marking, UKCA marking, China RoHS

## Inputs

Number of measurement channels

1

Connectors

Microdot connector

For piezoelectric accelerometer

Max. input charge 100,000 pC

For accelerometer with integrated preamplifier

CCLD 24 V 4 mA

For TEDS compliant accelerometer with integrated preamplifier

CCLD 24 V 4 mA

7-pin preamplifier connector

For connection of piezoelectric accelerometer via preamplifier (VP-26A)

Max. input voltage  $\pm 10$  V

## Measurement modes and units

Acceleration/velocity/displacement (selectable)

ACC (acceleration): m/s<sup>2</sup>

VEL (velocity): mm/s

DISP (displacement): mm

Display characteristics

Selectable from:

RMS

EQ PEAK ( $\text{RMS} \times \sqrt{2}$ )

EQ P-P ( $\text{EQ PEAK} \times 2$ )

Range selection

7 settings (range changes with sensitivity setting)

Sensitivity 0.100 to 0.999

ACC (acceleration):

10, 30, 100, 300, 1000, 3000, 10000

VEL (velocity):

10, 30, 100, 300, 1000, 3000, 10000

DISP (displacement):

1, 3, 10, 30, 100, 300, 1000

## Sensitivity 1.00 to 9.99

ACC (acceleration):

1, 3, 10, 30, 100, 300, 1000

VEL (velocity):

1, 3, 10, 30, 100, 300, 1000

DISP (displacement):

0.1, 0.3, 1, 3, 10, 30, 100

## Sensitivity 10.0 to 99.9

ACC (acceleration):

0.1, 0.3, 1, 3, 10, 30, 100

VEL (velocity):

0.1, 0.3, 1, 3, 10, 30, 100

DISP (displacement):

0.01, 0.03, 0.1, 0.3, 1, 3, 10

## Sensitivity settings

Setting range

0.100 to 0.999 in 0.001 increments

1.00 to 9.99 in 0.01 increments

10.0 to 99.9 in 0.1 increments

Units

pC/(m/s<sup>2</sup>) (Piezoelectric accelerometer)mV/(m/s<sup>2</sup>) (Accelerometer with integrated preamplifier)

(Accelerometer with integrated TEDS compliant preamplifier)

(Piezoelectric accelerometer connected via preamplifier [VP-26A])

## Frequency range

ACC (acceleration)

1 Hz to 15 kHz (AC output tolerance  $\pm 5\%$ )0.5 Hz to 30 kHz (AC output tolerance  $\pm 10\%$ )

VEL (velocity)

3 Hz to 3 kHz (AC output tolerance  $\pm 5\%$ )

DISP (displacement)

3 Hz to 500 Hz (AC output tolerance  $\pm 10\%$ )

Filters	<p>HPF (attenuation <math>-18</math> dB/oct, <math>-10\%</math> dB drop)</p> <p>3 Hz, 5 Hz, 10 Hz, 15 Hz, 20 Hz, 30 Hz, 50 Hz, 100 Hz, 150 Hz, 200 Hz, OFF</p> <p>LPF (attenuation <math>-18</math> dB/oct, <math>-10\%</math> dB drop)</p> <p>300 Hz, 500 Hz, 1 kHz, 1.5 kHz, 2 kHz, 3 kHz, 5 kHz, 10 kHz, 15 kHz, 20 kHz, OFF</p>
Display	<p>Segment-type LCD with backlight (constantly on)</p> <p>Display contents Unit settings, measurement value (1-s refresh cycle), bar graph (100-ms refresh cycle)</p> <p>Alarm indication LED <math>\times</math> 2</p> <p>Right-side LED</p> <p>Normally off. Lights up in red to indicate overload.</p> <p>Left-side LED</p> <p>Master/Slave indication (when linked to UV-22). Normally off. Lights up to indicate Master operation.</p>
Calibration signal output (for calibration of subsequent equipment)	
AC output	<p>Sinusoidal wave 80 Hz <math>\pm 2\%</math></p> <p>Output signal</p> <p>1 V (rms) <math>\pm 2\%</math> (RMS indication)</p> <p>1 V (peak) <math>\pm 2\%</math> (EQ PEAK indication)</p> <p>1 V (peak-to-peak) <math>\pm 2\%</math> (EQ P-P indication)</p>
DC output	1 V $\pm 2\%$

## Outputs

BNC connector × 2

### AC output

Output impedance 50 Ω

Output voltage accuracy (80 Hz full-scale)

ACC (acceleration) 1 V ±2%

VEL (velocity) 1 V ±3%

DISP (displacement) 1 V ±5%

Maximum output voltage

approx. ±10 V  
(peak)

### DC output

Output impedance 50 Ω

Output voltage accuracy

ACC (acceleration) 1 V ±2%

VEL (velocity) 1 V ±3%

DISP (displacement) 1 V ±5%

Maximum output voltage

approx. 10 V

## Inherent noise

Input capacitance 1000 pF, sensitivity 5.00 pC/(m/s<sup>2</sup>), piezoelectric accelerometer, HPF OFF, LPF OFF, minimum range

ACC (acceleration) 0.01 m/s<sup>2</sup> (rms) or less

VEL (velocity) 0.1 mm/s (rms) or less

DISP (displacement) 0.0015 mm (rms) or less



Power supply	9 V to 15 V DC Power consumption Approx. 140 mA (Using piezoelectric accelerometer: FRONT CHARGE setting, 12 V DC) Approx. 170 mA (Using accelerometer with integrated preamplifier : FRONT CCLD setting, 12 V DC )
Suitable AC adapter	NC-99 series (up to sixteen UV-15 units and one UV-22 unit) 80 VA or less when using sixteen UV-15 units (100 V AC)
Battery Unit	BP-17
Automotive 12 V battery	CC-82 (Car battery adapter)
Resume function	Memorizes all settings at power-off and restores the settings at the next power-on.
ID number	Serves to uniquely identify the unit in a system with up to 16 units, used in conjunction with UV-22.
Temperature and humidity conditions for use	-10°C to +50°C, max. 90% RH (no condensation)
Dimensions, Mass	150 mm (H) × 36 mm (W) × 179 mm (D) (without protruding part) Approx. 500 g

## Supplied accessories

Instruction manual	1
Link plate	1
Inspection certificate	1

## Optional accessories

Sound level Meter Unit	UN-14
Interface Unit	UV-22
AC adapter	NC-99 series (up to 16 units)
Battery Unit	BP-17
Piezoelectric accelerometer	Various
Accelerometer cable	Various
BNC-BNC cable	NC-39A
Rack Mounting Base	CF-27
Vibration meter preamplifier	VP-26A
Car battery adapter	CC-82

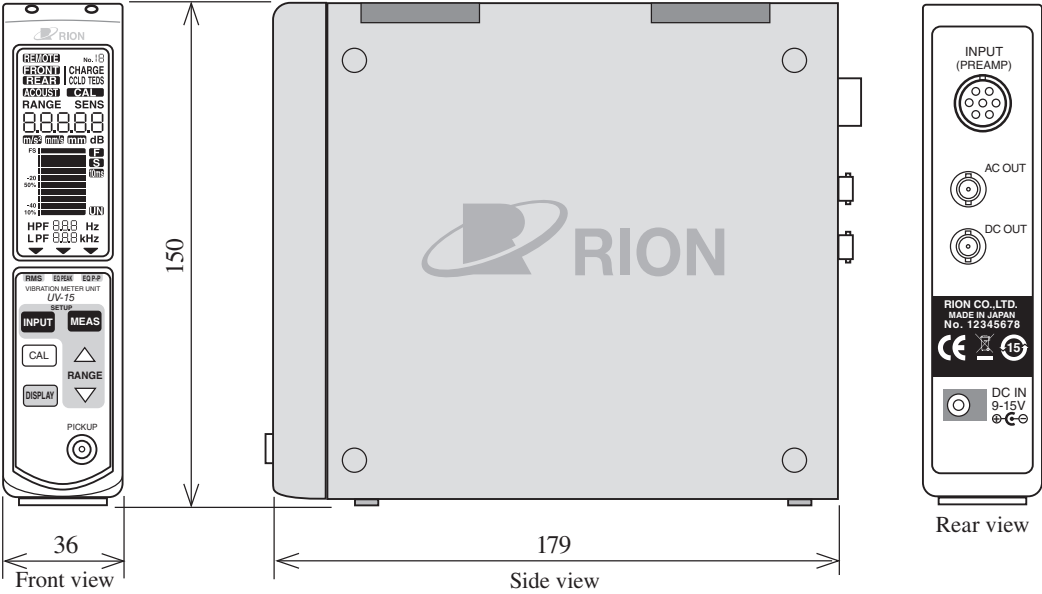

Unit: mm

Dimensional Drawings

# Rack Mounting Base

The dimensional drawing of the optional accessory, rack mounting base CF-27 is shown below.

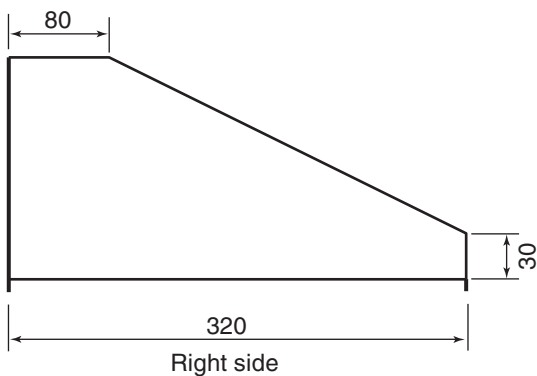
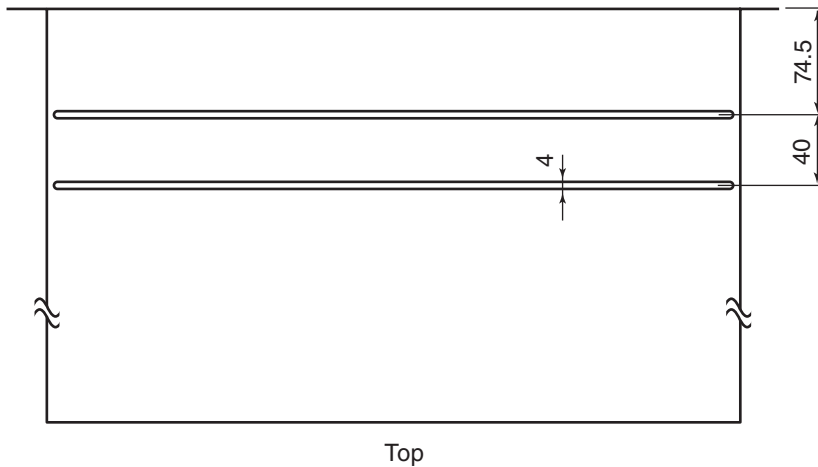
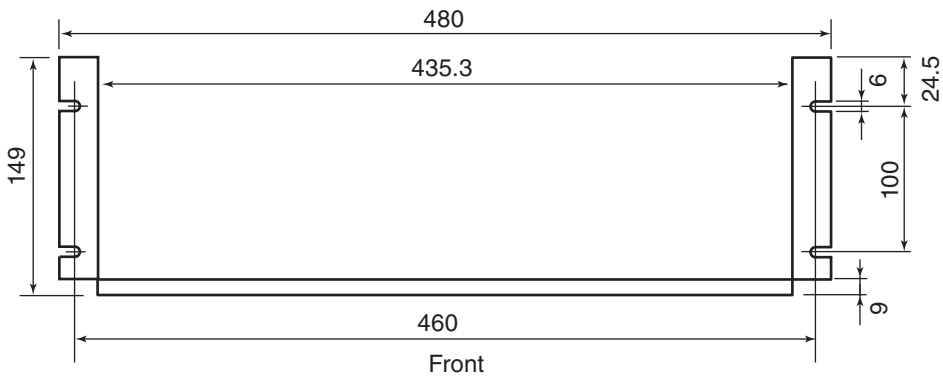

Board thickness: 1.6

Material: SPCC (cold rolled sheets)  
with rust prevention treatment

Painting color: Munsell N 7.5

Unit: mm

# Reference Material

## Delay of output signal

The UV-15 incorporates an A/D converter which converts the vibration input signal into digital format for processing by a DSP chip. The result is then returned to analog format by a D/A converter and output as an AC and DC signal. Due to this process, the output signal has a constant delay with regard to the vibration input signal, as shown below. This should be taken into consideration when using the unit.

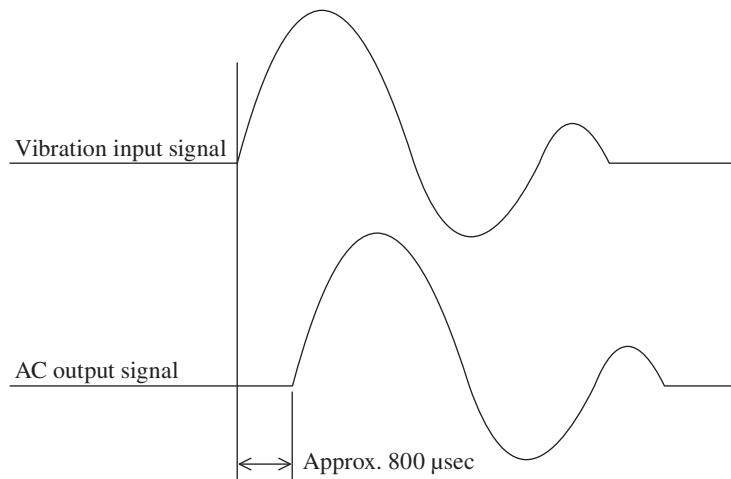

## User Filter

When used in conjunction with the UV-22, one each of the HPF and LPF characteristics shown below can be added as a user filter.

Available user filter frequency characteristics are as follows.

### UV-15 user filter characteristics for HPF

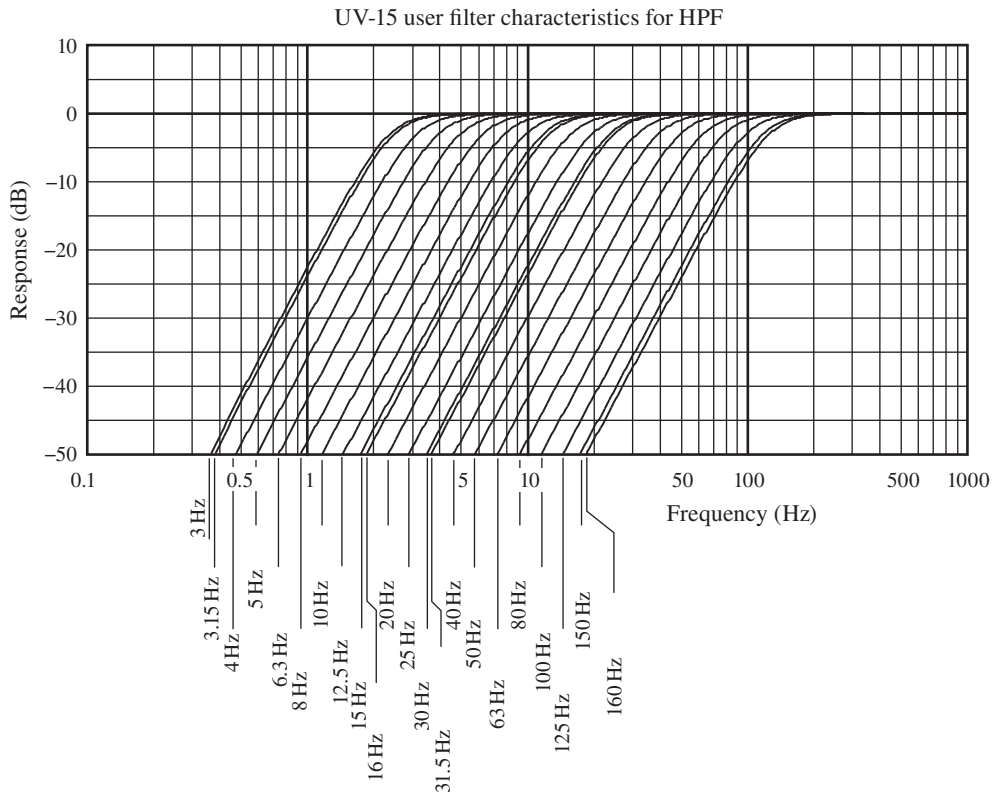

HPF (high-pass filter cutoff frequency:  $-10\%$  drop)

3 Hz, 3.15 Hz, 4 Hz, 5 Hz, 6.3 Hz, 8 Hz, 10 Hz, 12.5 Hz, 15 Hz, 16 Hz,  
20 Hz, 25 Hz, 30 Hz, 31.5 Hz, 40 Hz, 50 Hz, 63 Hz, 80 Hz, 100 Hz,  
125 Hz, 150 Hz, 160 Hz

Attenuation:  $-18$  dB/oct

## UV-15 user filter characteristics for LPF

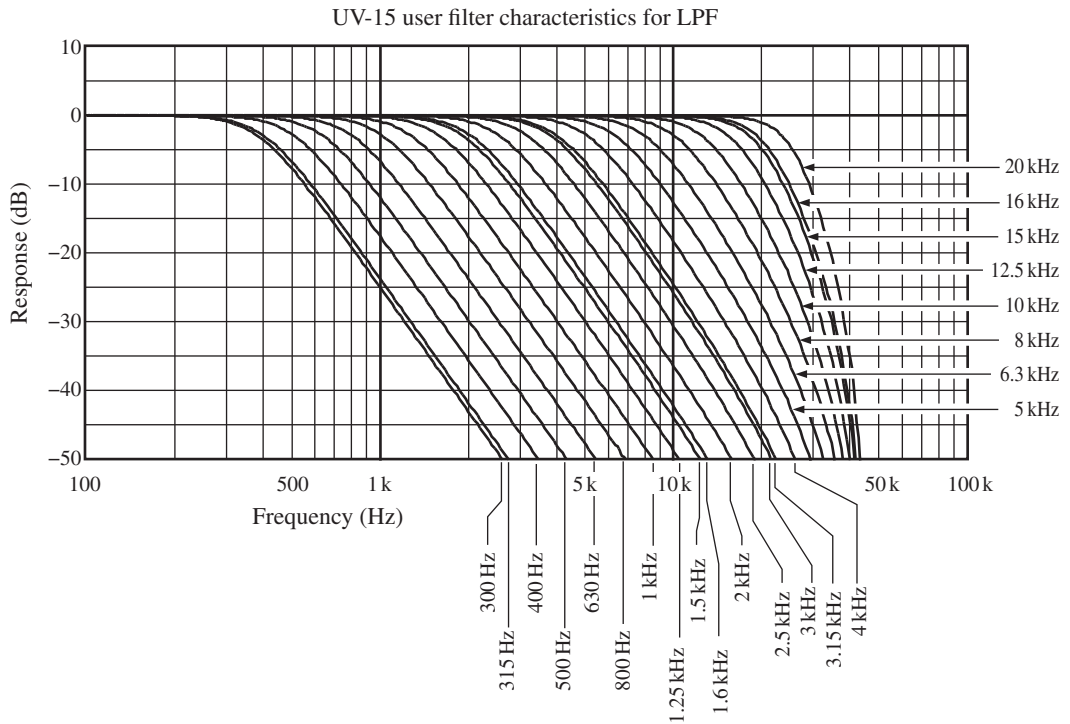

LPF (low-pass filter cutoff frequency:  $-10\%$  drop)

300 Hz, 315 Hz, 400 Hz, 500 Hz, 630 Hz, 800 Hz, 1 kHz, 1.25 kHz,  
1.5 kHz, 1.6 kHz, 2 kHz, 2.5 kHz, 3 kHz, 3.15 kHz, 4 kHz, 5 kHz, 6.3 kHz,  
8 kHz, 10 kHz, 12.5 kHz, 15 kHz, 16 kHz, 20 kHz

Attenuation:  $-18$  dB/oct

## Maintenance parts

If parts such as link hook, cover plate, or screws were lost by mistake, contact the supplier to obtain replacements.

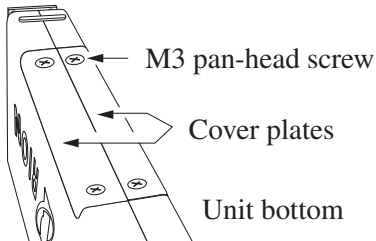

Part name: Cover plate  
Part number: UV-16-008

Part name: M3 pan-head screw  
Rion designation: KS 3 × 10  
Conventional market designation:  
pan-head screw M3 × 10  
Screw length 10 mm

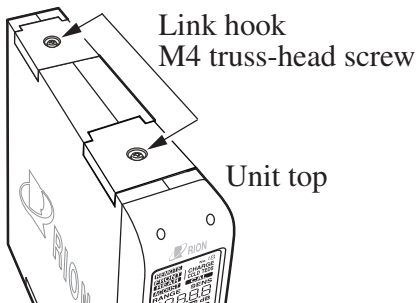

Part name: Link hook  
Part number: UV-16-004

Part name: M4 truss-head screw  
Rion designation: KT 4 × 8  
Conventional market designation:  
truss-head screw M4 × 8  
Screw length 8 mm

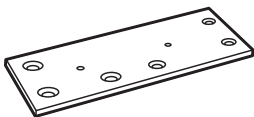

Link plate

Part name: Link plate  
Part number: UV-16-007





