

INSTRUCTION MANUAL

4 channel Data Recorder

DA-21



3-20-41 Higashimotomachi, Kokubunji, Tokyo 185-8533, Japan

<https://www.rion.co.jp/english/>

Organization of this manual

This manual describes the features, operation and other aspects of the 4 channel Data Recorder DA-21. If the unit is used together with other equipment to configure a measurement system, consult the documentation of all other components as well. The section starting on page iii contains important information and precautions about safety. Be sure to read and observe these in full.

This manual contains the following sections.

Outline

Gives basic information on the unit.

Controls and Functions

Explains the keys, indicators, connectors, and all other parts on the panels of the unit.

Power On/Off

Explains how to turn the unit on and off.

Display Explanation

Explains the various items that are shown on the display panel.

Menu Operations and Setting Items

Lists the basic steps that are common to all menus, and explains the individual setting items.

Preparations

Explains checks and other steps to take before starting to record. Sensor connection and setup as well as other functions are also explained here.

Recording

Explains the recording process as well the voice memo and marker functions.

Recall/Playback of Recorded Data

Explains how to recall and delete recorded data.

Messages

Explains the meaning of messages that appear on the display and countermeasures to take in response to such messages.

Filter Characteristics

Shows the high-pass filter and low-pass filter characteristics.

Settings and Other Information

For convenient reference, this section lists all menu settings, data recording operation types, and other relevant information.

WAVE File Format

Provides information about the WAVE file format used by the unit.

Specifications

Lists the technical specifications of the unit.

- * Company names and product names mentioned in this manual are usually trademarks or registered trademarks of their respective owners.



The product described in this manual is in conformity with the following European standards;

Conforming Standards

CE Marking

Low Voltage Directive: 2014/35/EU EN61010-1:2010

EMC Directive: 2014/30/EU EN61326-1:2013

RoHS Directive: 2011/65/EU EN50581:2012

This product can be used in any areas including residential areas.

To conform to the EU requirement of the Directive on Waste Electrical and Electronic Equipment, the symbol mark on the right is shown on the instrument.



FOR SAFETY

In this manual, important safety instructions are specially marked as shown below. To prevent the risk of death or injury to persons and severe damage to the unit or peripheral equipment, make sure that all instructions are fully understood and observed.

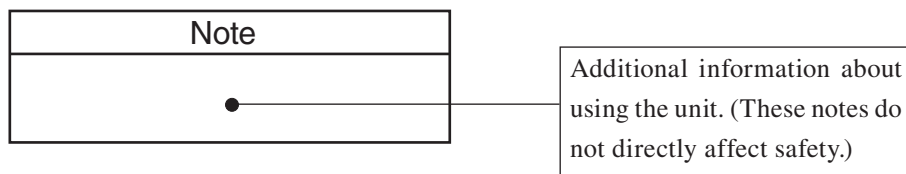
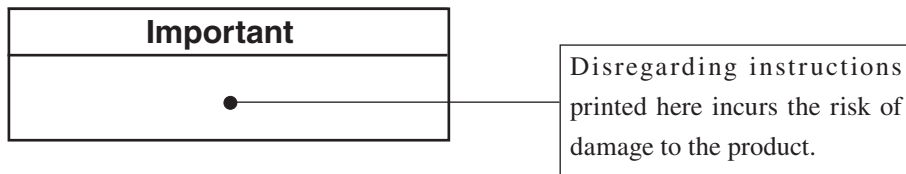
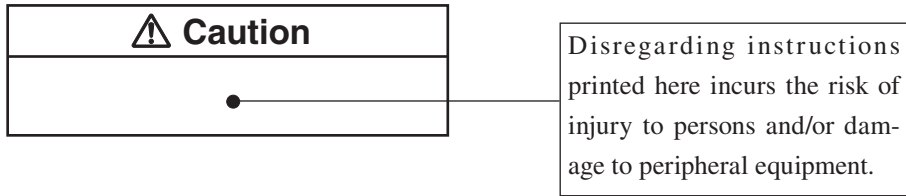

Caution

When using earphones, beware of excessive volume levels

When connecting earphones to the Monitor Out connector of this unit, use only earphones with a volume adjustment function, because there is a risk of excessive volume levels.

Do not play the supplied disc in a CD player

The supplied viewer software installation disc is not a music CD. Inserting this disc in a CD player poses the risk of excessive volume levels that can cause hearing damage and damage to the CD player.

Be careful around rotating machinery

When using the unit near rotating machinery, take care that cables cannot be caught in the machinery.

Avoid excessive force and abrupt operation

Applying strong force to the keys or card slot cover of the unit can lead to damage and injury. When connecting or disconnecting cables and opening or closing the card slot cover, take care not to pinch your fingers.

Important

Check the install CD before installation

Before inserting the supplied viewer software install CD in the CD-ROM drive of a computer, be sure to visually check the disc. If there are any cracks or scratches or if the disc is deformed, do not insert the disc in the CD-ROM drive. Otherwise there is a risk of damage to the CD-ROM drive.

Handle batteries correctly

If batteries are inserted with wrong polarity or otherwise mishandled, battery fluid may leak and overheating may occur.

Do not apply excessive voltage

Make sure that voltage applied to the power supply connector (DC IN), to the Input connectors, and to the external trigger (Ext. Trig.) connector does not exceed the specified values. Otherwise there is a risk of damage to the unit.

Usage Precautions

- Operate the unit only as described in this manual.
- Observe the following conditions with regard to locations for use and storage of the unit:
 - Do not use or store the unit in locations where the specified permissible range for temperature and humidity may be exceeded (–10°C to +50°C, max. 90% RH).
 - Do not use or store the unit in locations where there are rapid and drastic changes in temperature or where there is a possibility of condensation.
 - Do not use or store the unit in locations that may be subject to splashes of water or other liquids.
 - Do not use or store the unit for an extended time in locations that may be exposed to direct sunlight.
 - Do not use or store the unit in locations that may be subject to air with high salt or sulphur content, or subject to the influence of gases and other chemicals.
 - Do not use or store the unit in slanted or instable locations.
 - Do not use or store the unit in locations that may be subject to vibrations or shock.
- If batteries are inserted with wrong polarity or otherwise mishandled, battery fluid may leak and overheating may occur.
- Make sure that voltage applied to the power supply connector (DC IN) and to the signal Input connectors does not exceed the specified values.
- Take care that cables and other parts cannot be caught in rotating machinery.
- Do not apply strong force to the keys or card slot cover of the unit. Otherwise there is a risk of damage to the unit or injury to fingers etc. When connecting or disconnecting cables and opening or closing the card slot cover, take care not to pinch your fingers.
- Use only earphones with volume control function at the Monitor Out connector of this unit, and beware of excessive volume levels.
- Use only SD memory cards supplied by Rion. Other commercially available cards may not operate properly with the unit.

- Verify before use that all cables are correctly and safely connected. Do not bend cables sharply or subject them to pressure. When removing cables, always grasp the plug or connector and do not pull the cable.
- Do not apply strong shock to the connected cables to the unit. Otherwise the cables may remove from the unit.
- If it starts raining while using the unit outside, stop the measurement and protect the unit from getting wet. In case the unit gets wet, wipe it with a dry cloth and let it dry in a well-ventilated place.
- Always turn the unit off after use. Remove the batteries from the unit if it is not to be used for a long time. Otherwise battery fluid may leak, posing a risk of corrosion and damage. Also disconnect the AC adapter or battery pack.
- Do not tap the LCD panel or other surfaces of the unit with a pointed object such as a pencil, screwdriver, etc.
- Take care that no conductive objects such as wire, metal scraps, conductive plastics etc. can get into the unit.
- Do not disassemble the unit or attempt internal alterations. In case of malfunction, do not attempt any repairs. Note the condition of the unit clearly and contact your supplier.
- Clean the unit only by wiping it with a soft, dry cloth or, when necessary, with a cloth lightly moistened with water. Do not use any solvents, cleaning alcohol or chemical cleaning agents.
- When returning the unit for maintenance or servicing, use the original packing to protect it from shocks and vibration.
- The life of the backup battery for the internal clock of the unit is limited. You should have the battery replaced about once every five years. Regarding replacement of the battery, please contact your supplier.
- Please note that this product is warranted up to the product purchase price against defects in material.
- Dispose of the unit and of batteries only according to national and local regulations at the place of use.

AC adapter precautions

- Use only the specified AC adapter available as an option for the DA-21 (NC-98 series). Use of any other adapter can lead to damage or unexpected accident. Take care not to mix up the AC adapter with the AC adapter of another product.

Open source software

This product contains the open source software of the following licenses.

- (1) GPL
- (2) GPL v 2
- (3) GPL v 3
- (4) Boost Software License

Those source codes of the open source software according to the license agreement will be given. Those source codes are available for download from the Rion Support Room (<https://svmeas.rion.co.jp/>).

Note that we assume no responsibility for the source code.

Note that we are not responsible for exact details of the source code.

For details on the license, click [Manual] - [Open Source License] folder in the supplied CD-ROM.

이 기기는 가정용(B급) 전자파적합기기로서 주로 가정에서 사용하는 것을 목적으로 하며, 모든 지역에서 사용할 수 있습니다.

Contents

FOR SAFETY.....	iii
Outline	1
Controls and Functions.....	5
Front panel.....	5
Top panel	10
Right side panel	12
Bottom panel	13
Power On/Off.....	14
Display Explanation	17
Display screen	17
Menu Operations and Setting Items	30
General menu operation steps	30
Menu Items	39
<Input> menu.....	39
<Rec.Parameters> menu.....	44
<Trigger> menu.....	46
<Bar Graph> menu.....	50
<System> menu.....	51
<Synchronization> menu.....	55
Preparations	56
Preparations and checks before recording.....	57
Power supply	57
SD memory card preparations	61
External equipment (sensor etc.) connections	64
Input settings.....	65
Recording parameter settings.....	70
Input range setting.....	70
Sampling	73
Recording process	74
Auxiliary function setup.....	84
Device index number (<System> menu: Index).....	84
Voice memo/marker	85

Preventing inadvertent operation (key lock and menu lock)	87
Remote control operation	89
Connection to a computer	90
Inter-unit synchronization	91
Tachometer signal input	93
Recording.....	94
Recording steps	94
1. Checks before recording	94
2. Input range setting / Calibration signal recording	96
3. Recording	98
Using the voice memo/marker function.....	102
Data recording example	105
Recall/Playback of Recorded Data	108
Activating recall mode.....	108
Playback of recorded data	111
Canceling recall mode	115
Other information	115
Messages.....	119
Filter Characteristics	128
Settings and Other Information	129
Approximate recording times	129
Menu items	130
Data recording	133
Representative value of inherent noise	138
Power save settings	138
WAVE File Format.....	139
Basic structure	139
Basic WAVE file structure.....	139
File structure and size	140
Invalid values.....	141
Data types.....	142
Chunks	143
Specifications	152

Outline

The DA-21 is a compact, lightweight data recorder designed for waveform recording. The unit can be powered from batteries, for convenient use in the field.

To record sound or vibration waveforms, microphones or accelerometers can be connected easily. The capability for sensor drive power supply (CCLD) is also provided. Unlike with conventional units having only general-purpose connectors, the design of the DA-21 eliminates the need to set up additional connection equipment, allowing quick and uncomplicated recording start.

Features

The unit has the following features.

- Simultaneous recording of electrical signals in up to 4 channels. Compact and lightweight body ensures easy portability. A set of four IEC LR6 (size AA) alkaline batteries will power the unit for about 8 hours of continuous use (at 23°C, frequency range setting 100 Hz, 4-channel input, CCLD off, backlight off).
- CCLD support allows easy hookup of sensors including microphones and accelerometers.
- A wide range of sensors for converting sound pressure, vibrations, rotation, temperature or other measurement quantities into an electrical signal (AC or DC) is supported. Measurement quantities measured by sensors are displayed in units “V”, “V/EU”, “mV/(m/s²)” or “dB” with a user selectable setting range.
- Frequency range from DC to 20 kHz allows recording of a wide range of phenomena.
- Recorded data are stored on SD memory card in the commonly used WAVE format. When using an empty 32 GB card for example, the maximum available recording time with the 20 kHz frequency range setting and continuous recording in 4 input channels is about 23 hours. Depending on the setting for recording data, multiple WAVE files may be created.
- Voice memo and marker information can also be recorded, to facilitate later data management.

- Accurate playback of data is possible, making it easy for example to check the reliability of data in the field. The playback signal can also be output to an analyzer or similar equipment.
- The supplied viewer software may be used to import recorded data (including voice memos and marker information) from the SD card to check aspects such as waveform, frequency weighting characteristics, and time weighting characteristics. This software requires a Windows computer to run.
- Synchronize two DA-21 units to record signals simultaneously up to 8 channels.

System configuration

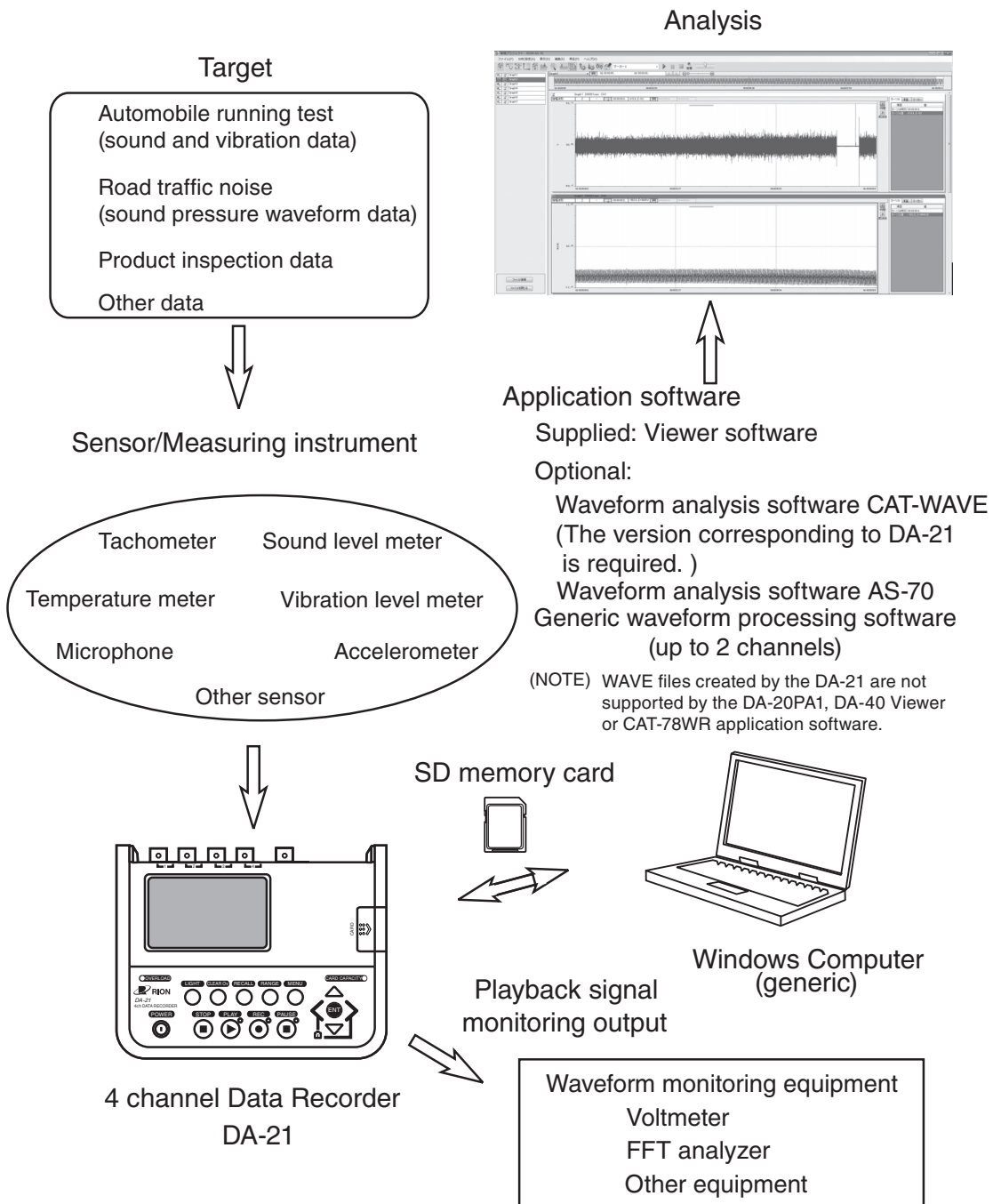

Operation environment

The DA-21 allows various operations for recording data. The general concept of the basic functions is as shown in the diagram below.

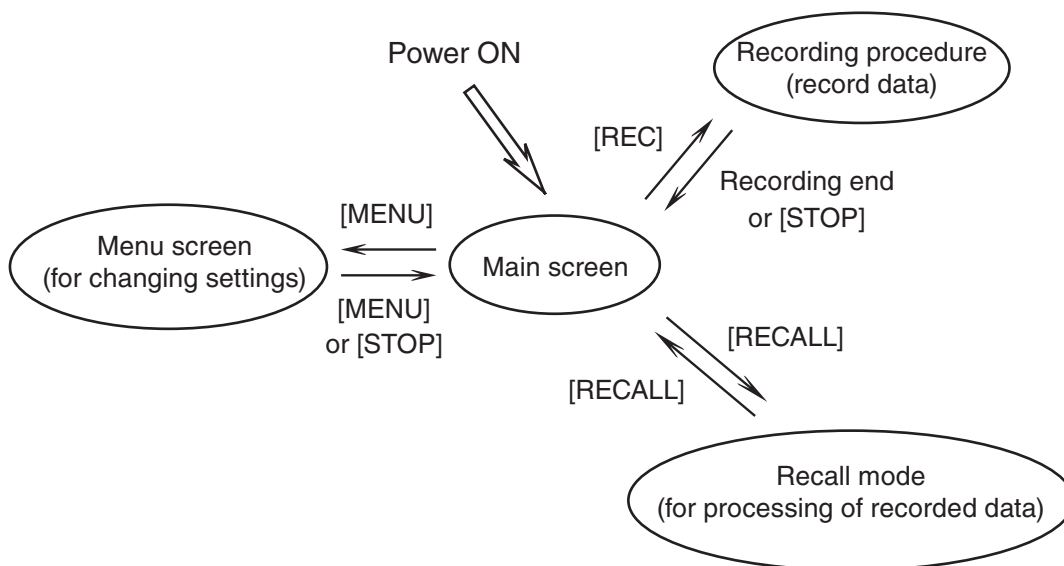

Main screen	This screen appears as the first screen, a short while after power to the unit is turned on. The menu screens, recording procedure, and recall mode are all accessed from the main screen. Input range selection is also possible from this screen.
Menu screen	Pressing the [MENU] key at the main screen brings up a menu screen. There are a number of menu screens that give access to recording parameters, input settings, and various other settings (see page 30).
Recording procedure	Pressing the [REC] key at the main screen initiates the recording procedure. This encompasses all steps required to record data (see page 94).
Recall mode	Pressing the [RECALL] key at the main screen activates the recall mode. In this mode, you can check, playback and delete recorded data (see page 108).

Controls and Functions

Front panel

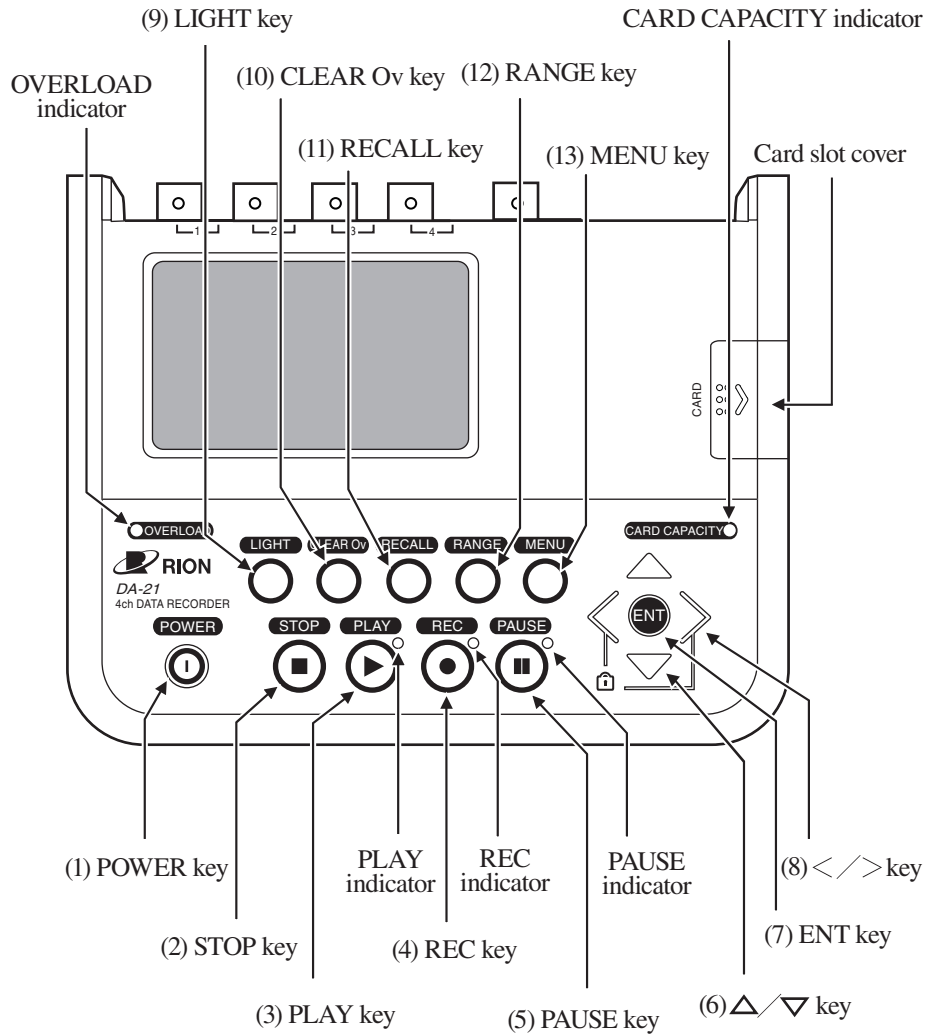

Display panel

Shows input data, recorded data, menus for changing settings, etc.

Key names and functions

The DA-21 has some dedicated keys that perform only a specific function, and some keys that perform various functions depending on the current operating state.

(1) [POWER] key

Serves to turn the unit on and off. The key must be kept depressed for about 2 seconds.

(2) [STOP] key

Serves to stop data recording or data playback. The key is also used for menu operations and other functions.

(3) [PLAY] key

Serves to start data playback.

(4) [REC] key

Serves to start data recording.

(5) [PAUSE] key

Serves to pause and resume data playback.

(6) [\triangle]/[∇] keys

These keys serve to switch the input range, select a monitor channel, and perform menu operations.

(7) [ENT] key

This key serves to confirm an item to be changed and accept a setting that has been made. It is used when setting the input range, performing menu operations, etc.

(8) [<]/[>] keys

These keys serve to change the data display format, change the file number, perform fast reverse/forward during playback, and perform menu operations.

(9) [LIGHT] key

Serves to control backlighting of the LCD screen. The backlight is turned on or off depending on the key press timing. When the LCD backlight has been activated, it will automatically turn itself off if there has been no key activity for a certain period. (The duration of this period can be changed with a menu setting.)

Note
When the remaining battery capacity is low and the battery icon (page 23) is flashing, the backlight does not operate.

(10) [CLEAR Ov] key

Serves to clear the overload history display. This display indicates if there has been any overload condition between the point when the key was last pressed and the current time (see page 24).

(11) [RECALL] key

Serves to activate the recall mode and to cancel the recall mode and return to the main screen.

(12) [RANGE] key

Serves to activate and cancel the input range setting condition. In recall mode, the key serves to delete the recording data selected by cursor.

(13) [MENU] key

Serves to bring up a menu screen or return to the main screen.

There are a number of menu screens which allow changing the settings of the unit. Menu screens are organized by function category, such as input settings, recording parameters, etc.

Key lock

Pressing and holding the [<] and [>] keys together for a few seconds activates the key lock condition. In this condition, all keys except the [<]/>] keys and the [LIGHT] key are inactive. The condition is indicated by a key lock icon that appears on the display (page 87).

To cancel the key lock condition, press and hold the [<] and [>] keys together once more.

Indicator names and functions

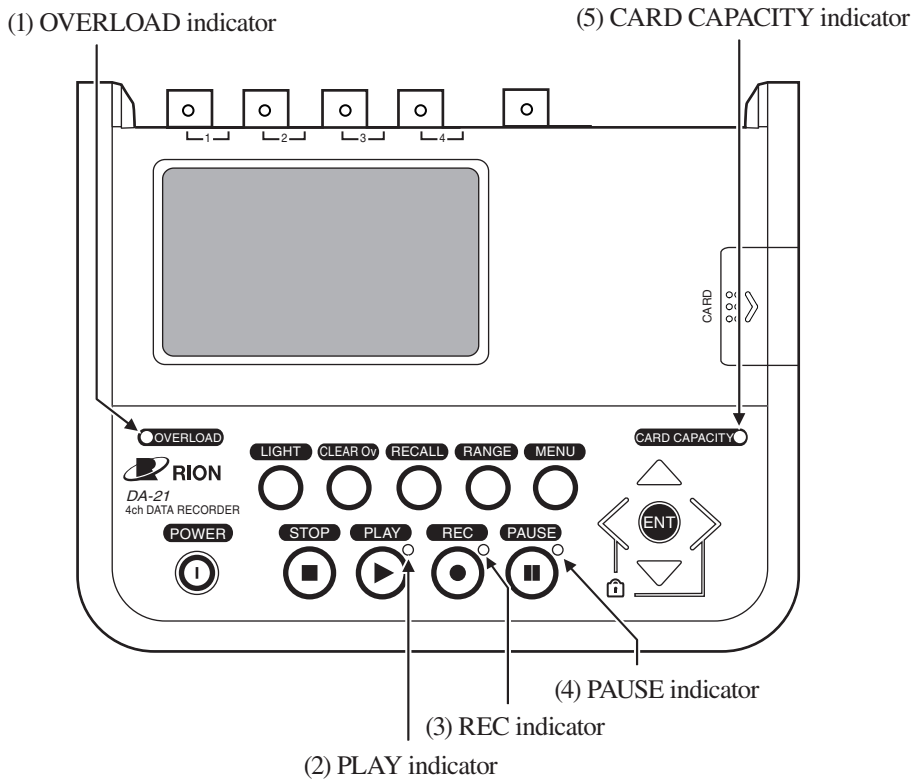

(1) OVERLOAD indicator

Indicates that the input signal level in a channel is excessive. While the indicator is lit, correct recording is not possible for that channel.

Lit in red: While the input signal is causing overload and for 1 second after the overload condition ceases, the indicator is lit.

(2) PLAY indicator

Indicates that recorded data are being played back.

Flashing in green: Recorded data are being played back.

(3) REC indicator

Indicates the operating condition during data recording.

Flashing in red: Data are being recorded.

Flashing in green: Unit is in trigger standby condition.

(4) PAUSE indicator

Indicates that data playback is being paused.

Flashing in blue: Data playback is being paused.

(5) CARD CAPACITY indicator

Indicates that the remaining data recording time on the SD memory card is less than 10 minutes.

Flashing in red: Data recording will stop within 10 minutes.

Also while the indicator is not flashing, the currently available recording time is shown on the display in the format “XXX:XX:XX”. Before starting to record, you should check this indication to make sure that the intended data can be recorded. If the remaining recording time will be about 10 seconds, recording stops.



Display example for available recording time shown on the second line from the bottom of LCD screen (Hours : Minutes : Seconds)

Top panel

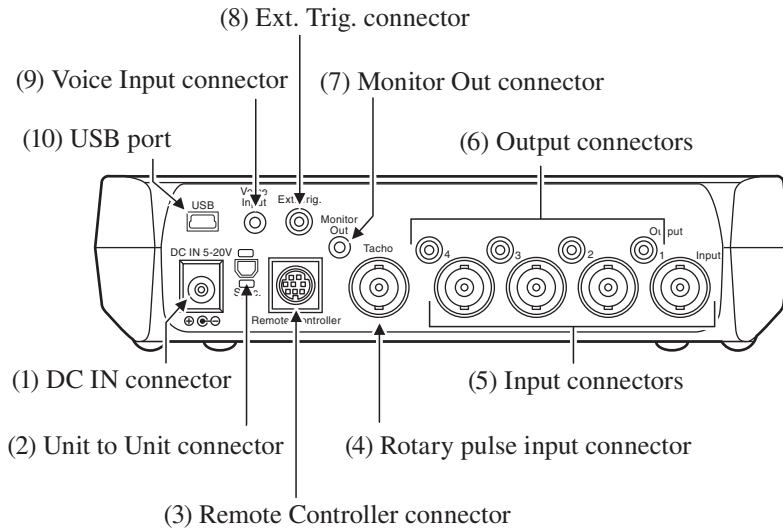

(1) DC IN connector

An optional AC adapter NC-98 series, car battery adapter CC-82, or battery pack BP-21A can be connected here.

Important
Do not connect any AC adapter or car battery adapter except for the specified models. Otherwise the unit may be damaged.
The optional car battery adapter is only for use in cars with a 12-V electrical system. If the adapter is used in a car with a 24-V electrical system to supply power to the DC IN connector of the unit, the unit will be damaged.
When connecting an external DC source to the DC IN connector, pay close attention to voltage rating and polarity. The allowable voltage range is 5 V to 20 V.
Even when using the battery pack BP-21A, please insert four usable batteries in the battery compartment.

(2) Unit to Unit connector

Use this connector to synchronize two DA-21 units.

(3) Remote Controller connector

Serves to connect the optional remote controller.

(4) Rotary pulse input connector

A rotary pulse signal (Tacho signal) of a fan, a motor etc. can be input here.

(5) Input connectors

These connectors are used to supply the input signal for recording.

(6) Output connectors

While recorded data are being played back in recall mode, the playback signal is available at these connectors.

(7) Monitor Out connector

The input signal or playback signal of the channel selected for monitor operation is output from this connector.

(8) Ext. Trig. connector

Accepts an external trigger signal.

(9) Voice Input connector

Serves to connect the optional microphone for the voice memo function.

(10) USB port

Serves for connection to a computer.

Right side panel

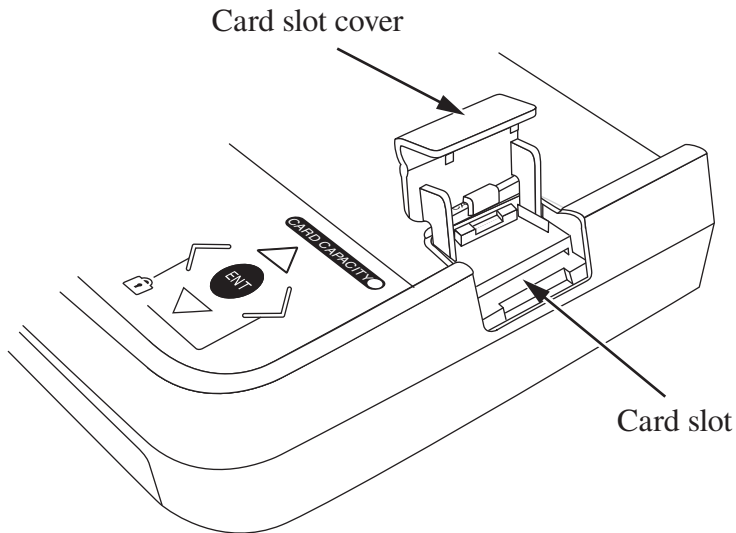

Card slot cover

Open this cover to access the SD memory card slot.

Card slot

The SD memory card is inserted here. The card allows storing data and exporting data to a computer. The card slot is also used for upgrading the system firmware etc.

Note
Use only RION supplied SD memory cards certified for operation in the DA-21. This unit supports SD memory cards and SDHC memory cards, but not SDXC memory cards.
When an SD memory card with a large number of files is inserted in the DA-21, the unit may take some time to recognize the card.

Bottom panel

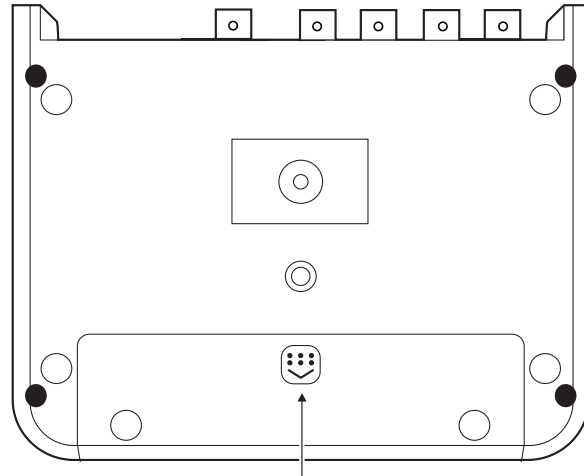

Battery compartment

Battery compartment

Accepts four alkaline batteries (IEC LR6 [size AA]).

Menu lock mode (see page 88):

When the [MENU] switch inside the battery compartment is set to “LOCK”, changing settings and deleting data via the menus is not possible.

Wake-up-on-power mode (see page 60):

When the [WAKE UP ON POWER] switch inside the battery compartment is set to “ON”, the unit is switched on and off in conjunction with the power supplied to the DC IN connector on the DA-21. In this case, the [POWER] key has no effect.

Important
Take care not to reverse the (+) and (–) polarity when inserting the batteries (see page 57).
When using the wake-up-on-power mode, there should be no batteries inserted in the unit.
Remove the batteries from the unit if it is to be stored for a long time with the [POWER] key set to OFF to prevent possible damage caused by battery leakage.
Even when using the battery pack BP-21A, please insert four usable batteries in the battery compartment.

Note
Before changing the position of these switches, disconnect any external power that is being supplied to the DC IN connector and remove all batteries from the battery compartment. Otherwise operation of the unit will become unstable. If this has happened (not a defect of the unit), disconnect the external power, remove all batteries, after a few seconds, reconnect the power and turn the unit on.

Power On/Off

Turning the power on

When you keep the [POWER] key depressed, the startup screen as shown below appears on the display. After a while, the main screen will be shown. If there is a setting file on the SD memory card, the main screen does not appear straight away. Instead, a message screen is shown asking whether you want to load the settings from the card, or use the settings that were established before power was last turned off.

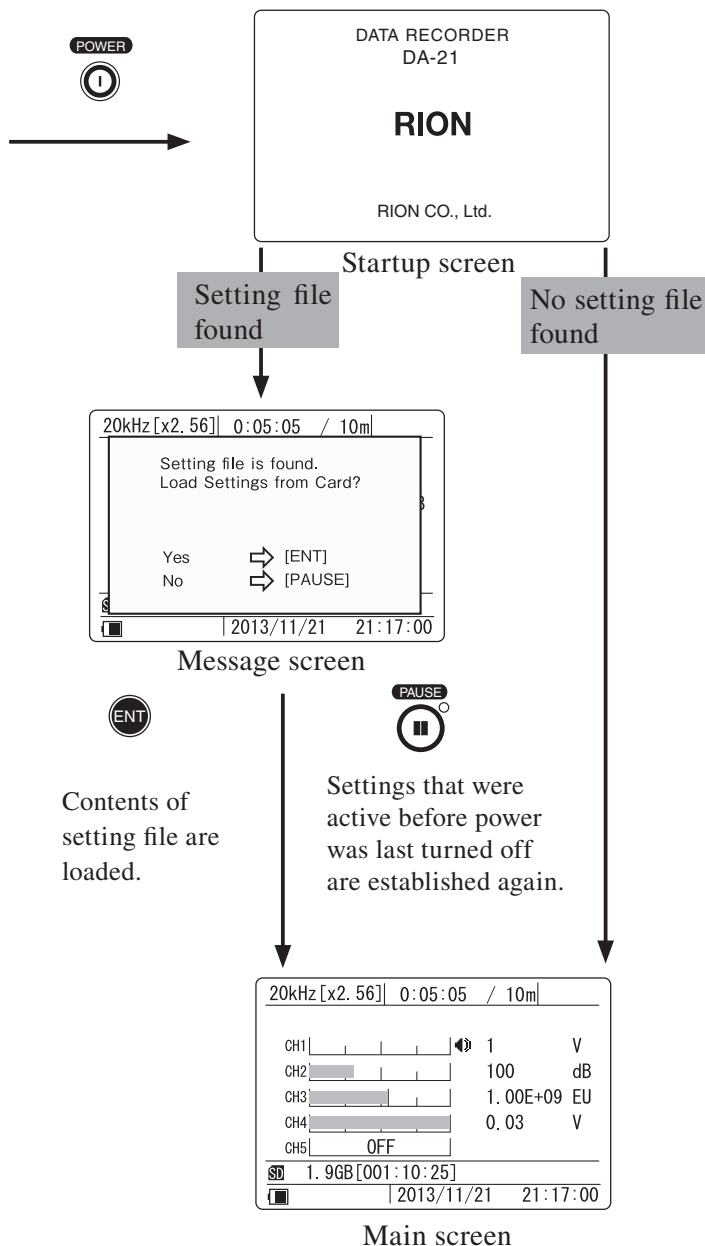

Note

The input range and menu settings etc. at power-on will be the same as the settings that were active before the unit was last turned off.

When the contents of a setting file are loaded at power-on, a channel selected for CCLD will be supplied with constant current. To prevent problems due to unsuitable connections, it is recommended to disconnect sensors before loading a setting file.

Turning the power off

When you keep the [POWER] key depressed, the shutdown screen as shown below appears on the display, and the unit is turned off.



Shutdown screen

Note that if a  icon is shown at the bottom of the display, the operation keys including the [POWER] key are locked. The power cannot be turned off in this condition. (For information on the key lock feature, see page 87.)

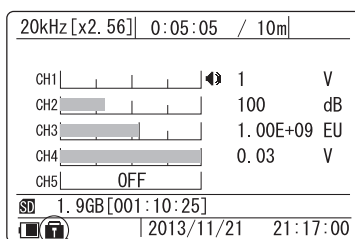

Indicates the key lock condition

Note

After turning the unit off, do not turn the unit on again immediately. Wait at least a few seconds.

In case key lock is activated, pressing and holding [POWER] key for 10 seconds or more will turn the unit off.
--

About the setting file

You can store all setting values and parameters of the unit on the SD memory card as a setting file (DA21.INI).

This capability allows you for example to store the optimum settings for a certain recording task and then quickly re-establish these settings at power-on. This reduces the time required for startup and the risk of making setup errors. To create a setting file, use the “Read / Save Settings” item on <System> menu. (see page 51)

Note
When the contents of a setting file are loaded at power-on, a channel selected for CCLD will be supplied with constant current. To prevent problems due to unsuitable connections, it is recommended to disconnect sensors before loading a setting file.

Display Explanation

Display screen

Recording/operation mode indication (page 20)

Recording parameter indication (page 18)

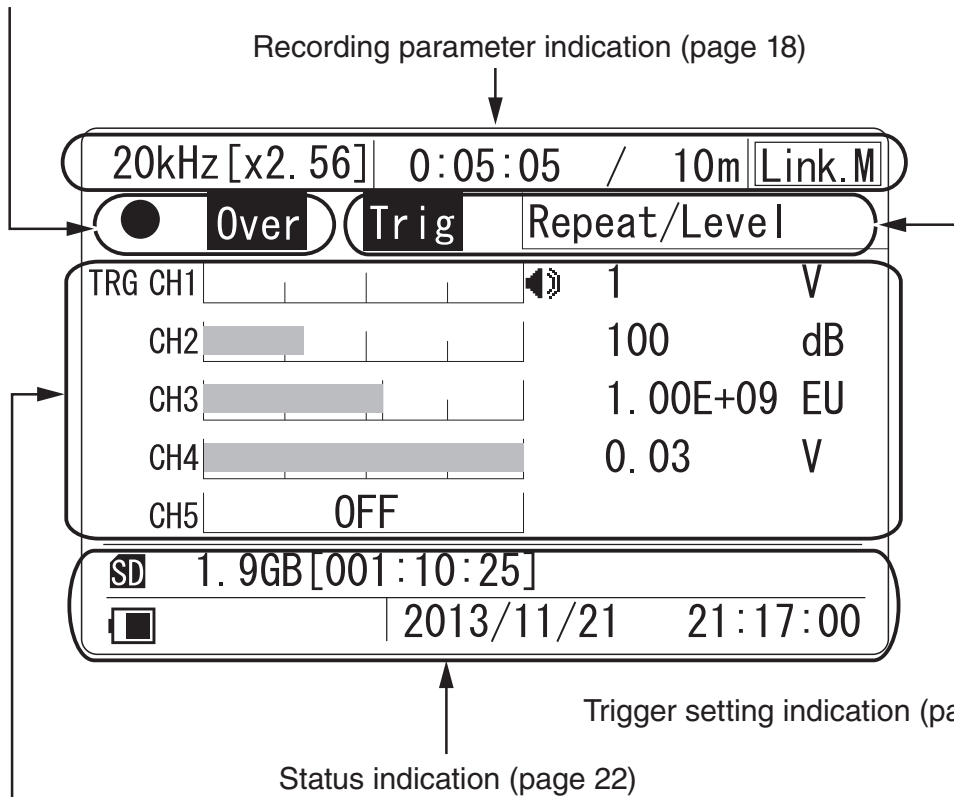

Trigger setting indication (page 21)

Status indication (page 22)

Channel data (page 24)

Recording parameter indication

From left, the display shows the frequency range [sampling frequency], elapsed recording time, recording time, and synchronization information.

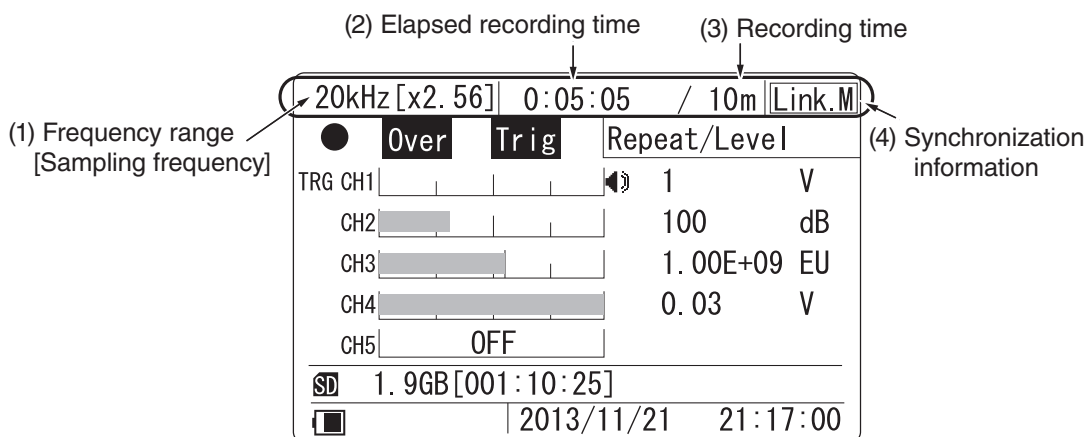

(1) Frequency range [Sampling frequency]

Shows the setting made with <Rec.Parameters> menu, items “Frequency Range” and “Sampling Frequency”. The relationship between frequency range and sampling frequency is as shown in the table below.

Frequency range	Sampling frequency	
	[x2.56]	[x2.4]
100 Hz	256 Hz	240 Hz
500 Hz	1.28 kHz	1.2 kHz
1 kHz	2.56kHz	2.4 kHz
5 kHz	12.8 kHz	12 kHz
10 kHz	25.6 kHz	24 kHz
20 kHz	51.2 kHz	48 kHz

(2) Elapsed recording time (Format: “0000:00:00”)

In recording mode, the elapsed time since the start of recording (including pre-recording time) is displayed. The recording time indication is retained until a new recording is started.

(3) Recording time (Format: “/ xx s [m, h]” or “/ Man”)

Shows the setting made with <Rec.Parameters> menu, item “Recording Time”. When the manual setting has been selected, the indication shows “/ Man”.

When the [STOP] key is pressed or the SD memory card runs out of space, recording stops. In this case, the actual recorded data time will be shorter than the recording time setting. (The recording time also includes the pre-recording time of 1 second or 5 seconds.)

(4) Synchronization information

If you synchronize two DA-21 units, the unit used as master shows “Link. M” and the unit used as slave shows “Link. S” (see page 90).

Recording/operation mode indication

This field shows recording and operation status information as well as all-channel overload information.

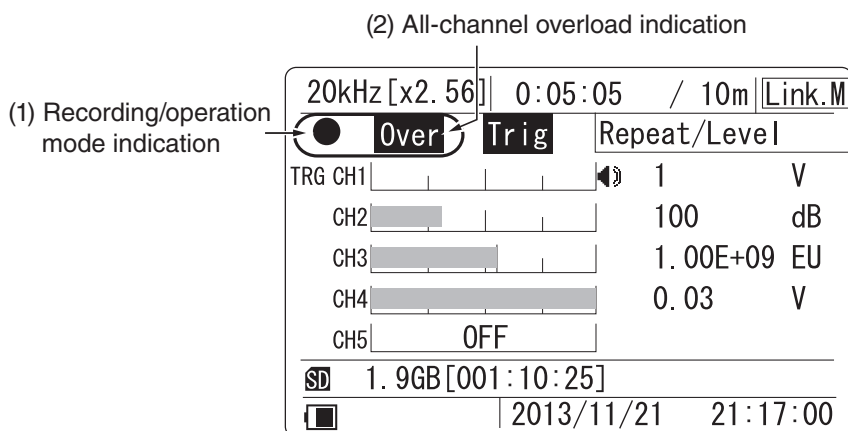

(1) Recording/operation mode indication

An icon indicates the current recording condition.

None	Normal condition
▶	Playback in progress (recall mode only), flashing
●	Recording in progress, flashing Trigger standby, permanently on
	Playback paused, flashing
◀◀	Rewind (recall mode only), flashing
▶▶	Fast-forward (recall mode only), flashing

(2) All-channel overload indication

This indication appears if there has been an overload condition in any channel. There are two types of indications, for instantaneous overload and overload history. The display method is the same as explained in the section on overload information (page 24).

Trigger setting indication

The trigger setting and type are shown here. When the trigger is set to OFF (Free), nothing is shown.

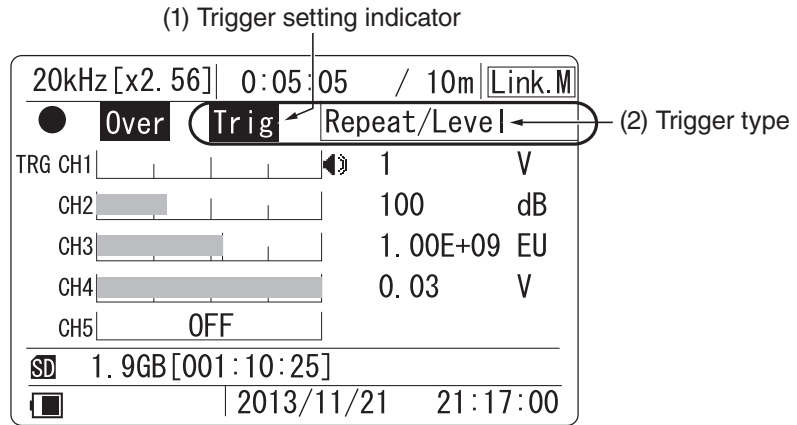

(1) Trigger setting indicator

This indicator appears if any trigger (except Free) has been set.

(2) Trigger type

None	Free trigger (no trigger setting)
“Single/Level”	Single level trigger
“Repeat/Level”	Repeat level trigger
“Single/Time”	Single time trigger
“Repeat/Time”	Repeat time trigger
“Single/Ext”	Single external trigger
“Repeat/Ext”	Repeat external trigger
“Single/Ext-Gate”	Single external gate trigger
“Repeat/Ext-Gate”	Repeat external gate trigger
“Master”	Master trigger

When a level trigger has been set, information about the trigger channel and trigger level is shown in the channel data area. For details on the channel data area, see the section starting on page 24.

Status indication

In the second line from the bottom, the display shows the card icon, card capacity (size/available recording time), and in the bottom line, the icon and clock (date/time).

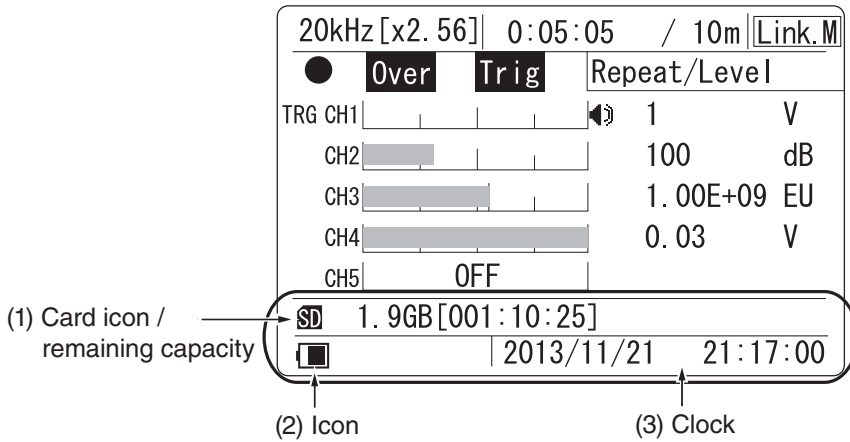

(1) Card icon/remaining capacity

The remaining card capacity is shown here in data size and the remaining recording time as calculated from the currently selected sampling frequency and number of active channels.

When no card is inserted, the card icon and remaining capacity indication are not shown, and the remaining recording time indication shows “---:--:--”.

(2) Icon

A graphic symbol representing the power supply status, key lock status, or menu lock status is shown here.

 : Shown when unit is being powered from an external source.

 : Shows the approximate remaining battery capacity when the unit is being powered from batteries. The number of black segments decreases as the batteries get depleted. When the indication starts to flash, replace the batteries with a fresh set.

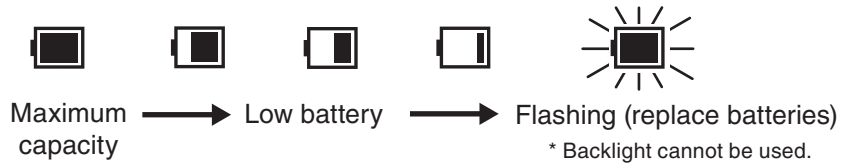

 : Indicates the key lock condition where the operation keys except for [LIGHT], [<], and [>] are disabled. (For details on the key lock function, see page 86.)

The condition is activated by pressing and holding the [<] and [>] keys together for a few seconds. Repeating the procedure cancels key lock and causes the icon to disappear.

The keys on the Remote Controller are not affected by the key lock function.

 : Indicates the menu lock condition where the menus cannot be used. (For details on the menu lock function, see page 88.)

 : Indicates the display backlight has been lit up.

(3) Clock

Shows the current date and time, using 24-hour format.

Channel data

From left, the display shows the level trigger target channel, channel number/overload information, bar graph, trigger level, monitor icon and range full-scale value.

The data for four channels are shown simultaneously on the display.

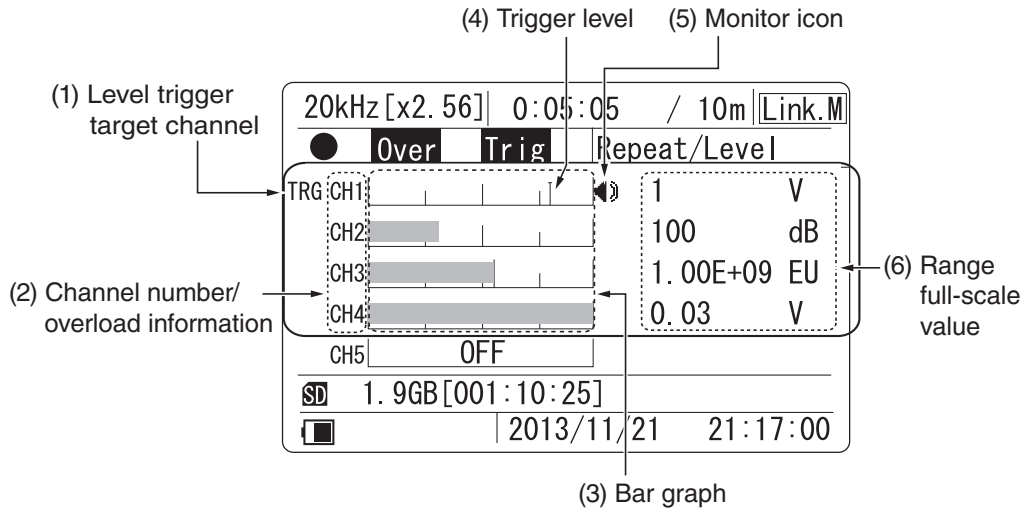

(1) Level trigger target channel

When the level trigger function is used, the indication “TRG” is shown to the left of the channel indication.

(2) Channel number/overload information

The channel number (CH1 to CH4) is shown here. If an overload signal is input, the channel number switches to the overload information.

There are two types of overload indications: instantaneous overload and overload history.

OVER	Shown when instantaneous overload has occurred.
OVER	Shown when overload has occurred at least once during recording (overload history).

The overload history indication is cleared in the following cases:

- Power-on
- [CLEAR Ov] key pressed
- Recording settings changed:
 - Frequency range
 - Sampling frequency
 - Input range
 - Channel setting (type, HPF, LPF, sensor type, scaling)
- Recording start
- When recall mode is canceled

(3) Bar graph

Shows the magnitude of the input signal, using one of the following three methods:

- Linear value display

This is used when “Linear” has been selected in the <Bar Graph> menu (see page 50). If the sensor type for the channel has been set to “SLM/VM” in the <INPUT> menu (see page 39), this mode cannot be selected.



- Logarithmic value display (bar graph covers about 80 dB)

This is used when “Log” has been selected in the <Bar Graph> menu. If the sensor type for the channel has been set to “SLM/VM”, this mode cannot be selected.



- dB value display (bar graph covers about 80 dB)

When the sensor type for the channel has been set to “SLM/VM”, this mode is always used, regardless of the <Bar Graph> menu setting.



- Channel OFF

This indication is shown when the respective channel is set to OFF.



(4) Trigger level

When level trigger is used, a vertical line on the bar graph for the respective channel shows the level trigger position.

(5) Monitor icon

The  icon is shown to the right of the bar graph for the channel selected for monitor output.

The monitor channel can be changed using the [Δ]/[∇] keys.

(6) Range full-scale value

Depending on the “Sens” and “Sensitivity” settings in the <Input> menu, the value corresponding to the bar graph full range point is shown here.

A list of the menu settings and values/units is shown in the table below.

<Input> menu “Sens” setting	Numeric range (number of digits)	Unit
V	0.01, 0.03, 0.1, 0.3, 1, 3, 10	“V”
EU	9.99E \pm 99	“V/EU”
MIC	-0.1 to -99.9 (5 digits, 0.1 dB step)	“dB”
PICK	9.99E \pm 99 (8 digits)	“mV/(m/s ²)”
SLM	40 to 140 (3 digits, 10 dB step)	“dB”
VM	40 to 140 (3 digits, 10 dB step)	“dB”

For information on changing the input range setting, see page 70.

CH5 data

The CH5 field either shows tachometer signal information or information about the use of the voice memo and marker function.

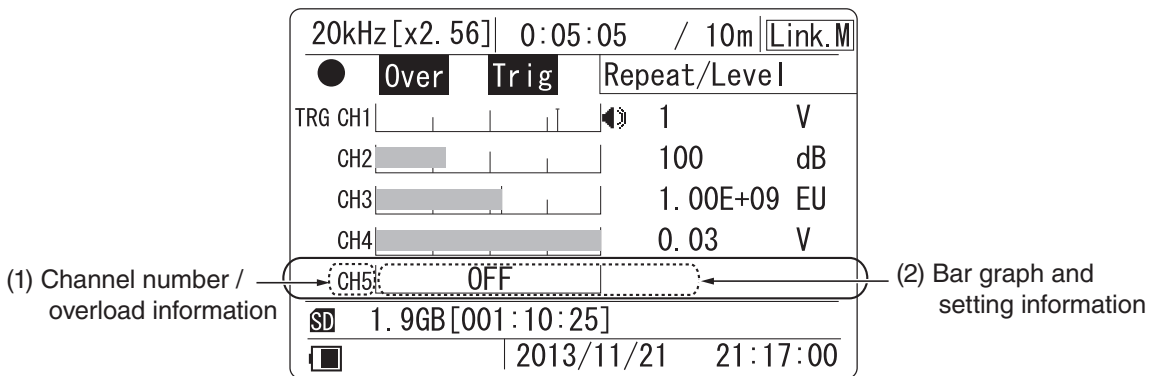

(1) Channel number/overload information

The channel number (CH5) is shown here. If an overload signal is input, the channel number switches to the overload information (see page 24).

(2) Bar graph and setting information

Depending on the setting made for “CH5” in the <Input> menu (see page 39), the display is switched as follows.

- “OFF” setting

“OFF” is shown in the bar graph area.

OFF

- “Tacho” setting

The rpm value of the input tachometer signal is shown.

--- r/min TC

When “Tacho” is selected, the overload/underload evaluation conditions are as follows.

Overload signal evaluation

- “Over” is shown when revolution speed reaches or exceeds 600,000 rpm.
- Above the upper limit of 630,000 rpm, the invalid indication “---” is shown.

Underload signal evaluation

- “Under” is shown when revolution speed is 200 rpm or lower.
- Under the lower limit of 190 rpm, the invalid indication “---” is shown.

- “Voice Memo” setting

The level of the voice memo input is shown in the bar graph area.



- “Marker” setting

“OFF” is shown in the bar graph area, and the icon flashes when the marker function is used.

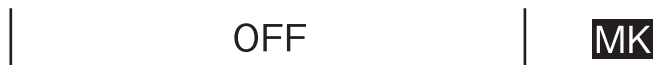

History display

Besides the bar graph format, the data display can also show a history graph of waveform data absolute values. (This is not available in recall mode.) To switch between the bar graph and history display, use the [>] or [<] key.

The data shown on the history display are the data of the monitor channel. The horizontal axis is the time (up to 20 seconds before), and the vertical axis is the level. Also during history display, you can switch the monitor channel with the [△]/[▽] keys.

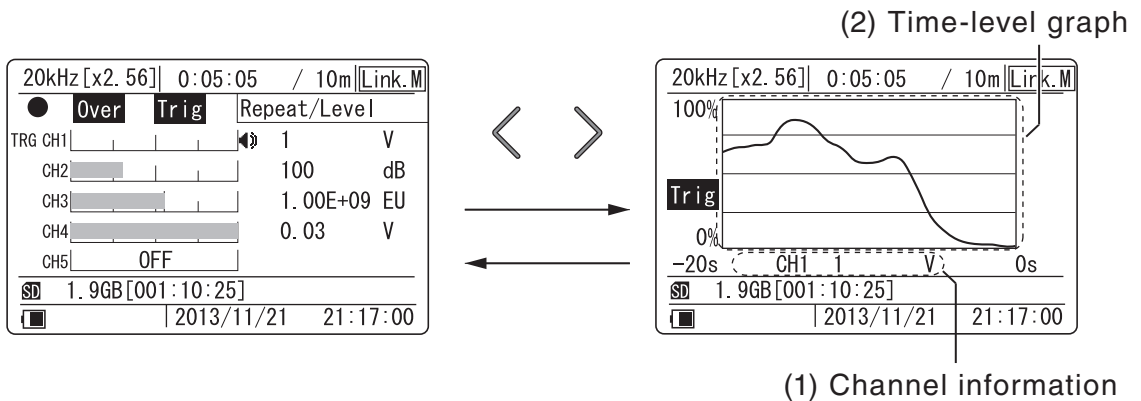

(1) Channel information

From left, the display shows the voice memo, tacho, or marker icon (when channel 5 is used), the channel number, and range full-scale.

(2) Time-level graph

The time-level graph shows a history graph for waveform data of the last 20 seconds in the monitor channel.

The graph is based on the approximate absolute (not the root mean square) values of the input waveform.

Menu Operations and Setting Items

General menu operation steps

Almost all settings of the DA-21 except for the input range setting are made via menus.

To make a setting, you call up the menu from the menu list page. When a menu has been selected, the screen with the individual settings of that menu appears.

There are a total of six menu pages, divided by category such as input related settings, recording settings etc. A detailed description of menu operation steps follows.

1. Call up the menu list

Press the [MENU] key. The menu list appears.

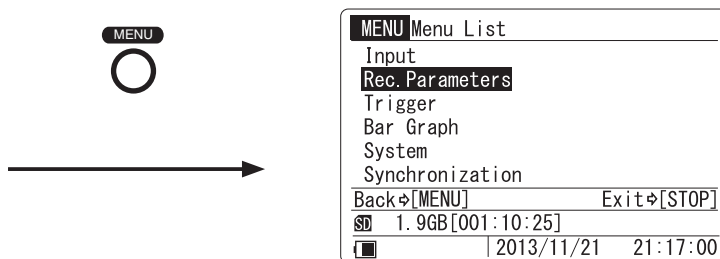

2. Select a menu page

Use the [△]/[▽] keys to move the cursor to the desired menu page.

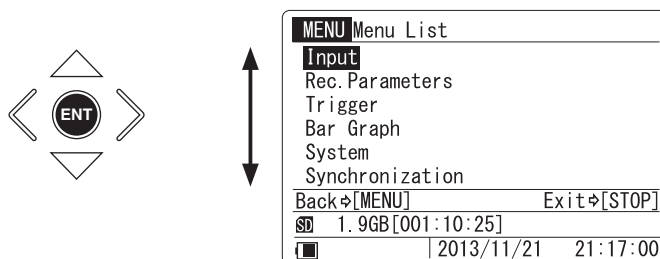

3. Open the menu page

Press the [ENT] key. The items on the selected menu page appear.

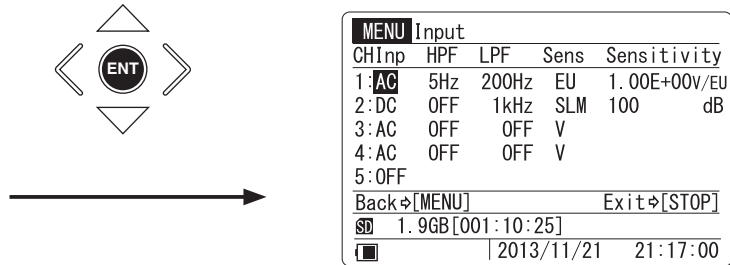

4. Select an item

Use the [Δ]/[∇] /[<]/[>] keys to move the cursor to the desired setting item.

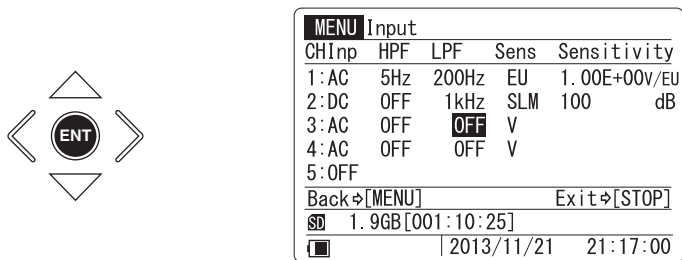

5. Initiate the change

Press the [ENT] key to start changing the selected item.

There are three ways of changing a setting, as follows.

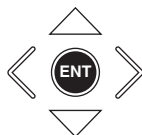

- A : Select setting item on sub menu
- B : Change setting value on sub menu
- C : Execute (process) selected item

6. Detailed explanation of methods A, B, C

A: Select setting item on sub menu

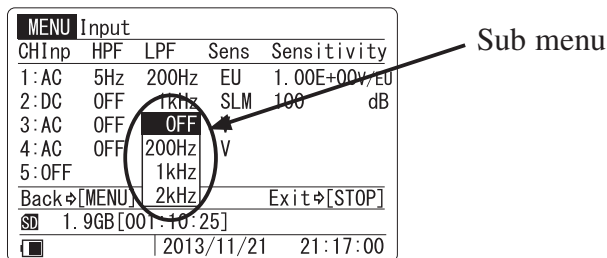

The sub menu appears when the [ENT] key is pressed. Select the setting from the sub menu. The following setting items have this type of sub menu.

- <Input> (Sensor signal type, High pass filter, Low pass filter, Sensor type)
- <Rec.Parameters> (Frequency Range, Sampling Frequency, etc.)
- <Trigger> (Trigger Mode, Trigger Type, etc.)
- <Bar Graph> Bar Graph Display Type
- <System> (Play Signal Output, Backlight Brightness, etc.)
- <Synchronization> (Master or slave selection)

The explanation below uses the channel 3 LPF setting on the <Input> menu as an example. The procedure is the same for other items.

A-1 Use the [Δ]/[∇] keys to move the cursor in the sub menu to the desired setting.

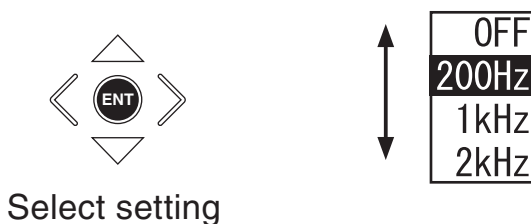

A-2 Press the [ENT] key. The change is accepted and the sub menu disappears.

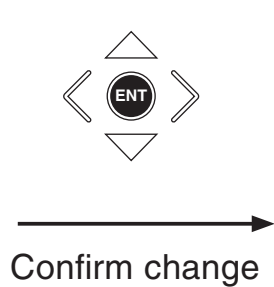

Confirm change

MENU Input				
CHInp	HPF	LPF	Sens	Sensitivity
1: AC	5Hz	200Hz	EU	1.00E+00V/EU
2: DC	OFF	1kHz	SLM	100 dB
3: AC	OFF	200Hz	V	
4: AC	OFF	OFF	V	
5: OFF				
Back⇨[MENU]		Exit⇨[STOP]		
SD 1.9GB[001:10:25]				
		2013/11/21 21:17:00		

LPF OFF setting has changed to 200 Hz

A-2' By pressing the [MENU] key or [STOP] key instead of the [ENT] key, you can cancel the sub menu without changing the setting. In this case, the indication is as shown below.

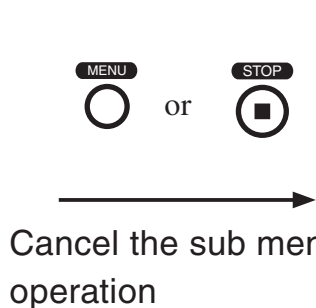

Cancel the sub menu operation

MENU Input				
CHInp	HPF	LPF	Sens	Sensitivity
1: AC	5Hz	200Hz	EU	1.00E+00V/EU
2: DC	OFF	1kHz	SLM	100 dB
3: AC	OFF	OFF	V	
4: AC	OFF	OFF	V	
5: OFF				
Back⇨[MENU]		Exit⇨[STOP]		
SD 1.9GB[001:10:25]				
		2013/11/21 21:17:00		

Setting remains OFF

B: Change setting value on sub menu

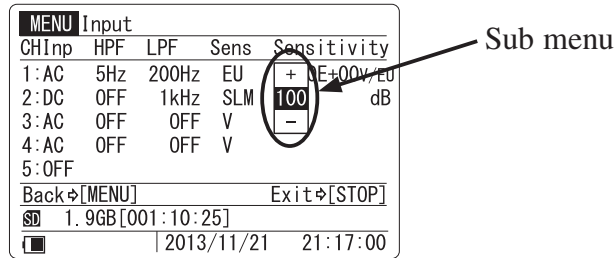

The sub menu appears when the [ENT] key is pressed. Change the setting value on the sub menu. The following setting items have this type of sub menu.

- <Input> (Sensitivity)
- <Rec.Parameters> (Recording time, Pre-recording time)
- <Trigger> (Trigger level, Recording start time, Recording stop time)
- <System> (Device index number, clock setting)

The explanation below uses the CH2 Sensitivity setting on the <Input> menu as an example. The procedure is the same for other items.

- B-1 Use the [Δ]/[∇] keys to change the value or unit of the item in the sub menu. Holding down a key causes a faster change.



Change setting value

B-2 Press the [ENT] key. The change is accepted and the sub menu disappears.

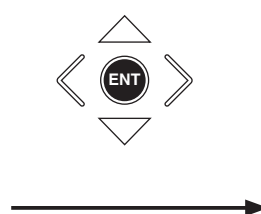

Confirm change

MENU Input				
CHInp	HPF	LPF	Sens	Sensitivity
1:AC	5Hz	200Hz	EU	1.00E+00/EU
2:DC	OFF	1kHz	SLM	130 dB
3:AC	OFF	OFF	V	
4:AC	OFF	OFF	V	
5:OFF				
Back⇨[MENU]			Exit⇨[STOP]	
SD 1.9GB [001:10:25]				
2013/11/21 21:17:00				

Sensitivity setting has changed to 130 dB from 100 dB

B-2' By pressing the [MENU] key or [STOP] key instead of the [ENT] key, you can cancel the sub menu without changing the setting. In this case, the indication is as shown below.

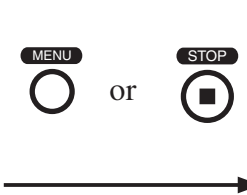

Cancel the sub menu operation

MENU Input				
CHInp	HPF	LPF	Sens	Sensitivity
1:AC	5Hz	200Hz	EU	1.00E+00/EU
2:DC	OFF	1kHz	SLM	100 dB
3:AC	OFF	OFF	V	
4:AC	OFF	OFF	V	
5:OFF				
Back⇨[MENU]			Exit⇨[STOP]	
SD 1.9GB [001:10:25]				
2013/11/21 21:17:00				

Setting remains 100 dB

C: Execute (process) selected item

This type of setting procedure applies to items such as “Card Format” and “Read / Save Settings” on the <System> menu. To execute the process, press the key corresponding to “Yes”. To cancel the process, press the key corresponding to “No”. When the process is completed, the original menu page appears again.

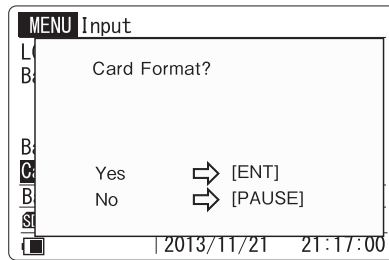

Execution choice example

This concludes the description of the three ways of changing a menu setting.

7. Changing an item on another menu page

Press the [MENU] key to bring up the menu list.

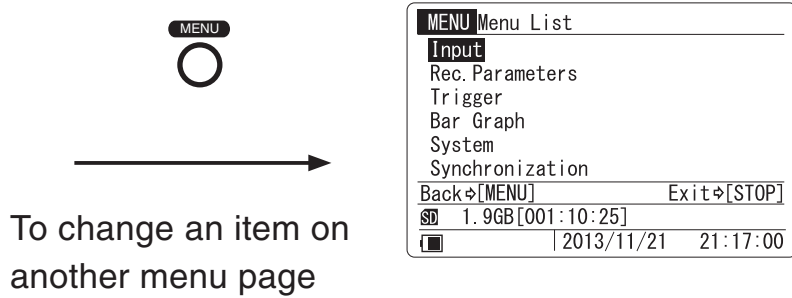

8. Return to main screen

Press the [MENU] key or [STOP] key to return to the main screen.

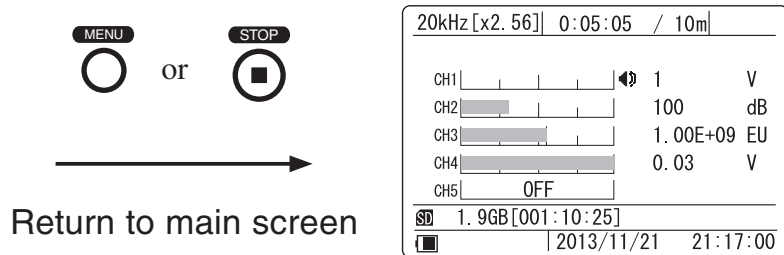

Menu flow diagram

The organization of all menu operations is shown in the diagram below. Note that you always have to use the menu list to go to a menu page.

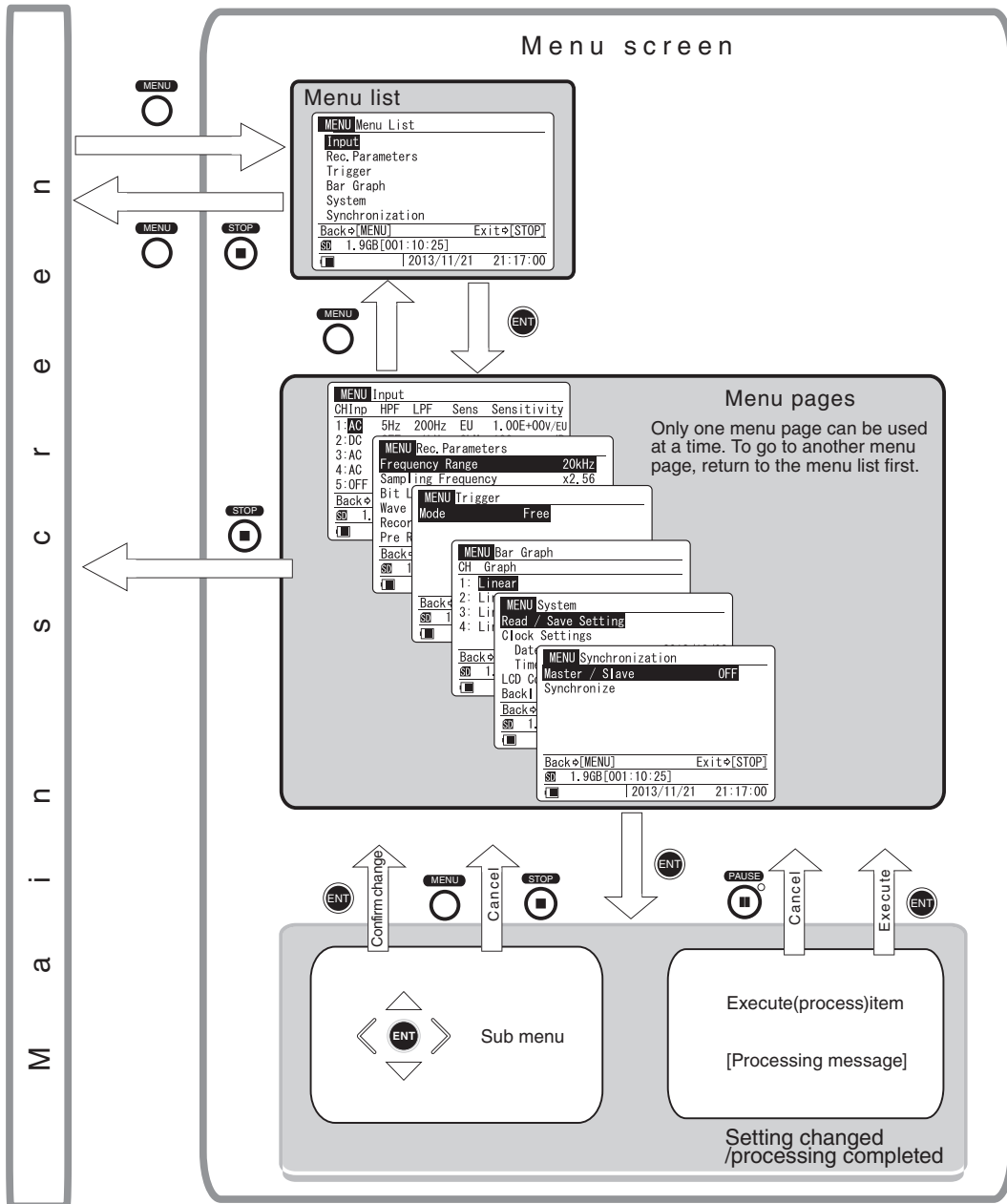

Menu Items

Setting items are organized in six pages, with related items appearing together on one page. The contents of each menu page are described below.

<Input> menu

Allows you to select the sensor (signal) type, input signal filtering, sensor sensitivity level and units for each channel.

MENU Input					
CH	Inp	HPF	LPF	Sens	Sensitivity
1:	AC	5Hz	200Hz	EU	1.00E+00V/EU
2:	DC	OFF	1kHz	SLM	100 dB
3:	AC	OFF	OFF	V	
4:	AC	OFF	OFF	V	
5:	OFF				
Back ↵ [MENU]			Exit ↵ [STOP]		
SD 1.9GB [001:10:25]					
[]			2013/11/21 21:17:00		

Inp Sensor (signal) type setting (CH1 to CH4)

Controls the input on/off setting and sensor (signal) type.

- OFF Select this setting when the input is not to be used.
- DC This setting is for input of an electrical signal, with the recording to include DC components. This is suitable for environment sensors (temperature, wind speed, pressure, etc.) and sound level meters that output the measurement value as a DC signal. The setting should also be used when recording a signal (such as from a vibration level meter) that comprises frequency components below 1 Hz.
- AC This setting is for input of a normal electrical signal, with the recording to exclude DC components. This is suitable for sound level meters, vibration meters and similar equipment that outputs the measurement value as an AC signal. The cutoff frequency is about 0.3 Hz.

Note

When Input is set to AC, a high-pass filter with a cutoff frequency of 0.3 Hz is applied. However, if the input signal contains high-level DC components that exceed the input range, overload may occur in the DA-21.

CCLD This setting is for microphones, accelerometers and other sensors that require a sensor drive power supply. (See the section starting on page 63.)

(CCLD: Constant Current Line Drive)

Note
<p>If the unit is operated on battery power, take the following points into account when setting the Inp to CCLD.</p> <p>When quitting the menu, if battery capacity is too low for supporting CCLD operation, the unit will switch itself off automatically.</p> <p>In such a case, replace all batteries with fresh ones, or connect an AC adapter or other external power supply.</p>

VP4x Select this setting when the accelerometer is connected to the unit via the charge converter VP-40 etc. (see page 63).

Inp Tachometer signal, voice memo, marker setting (CH5)

This setting determines which signal type information is shown in the CH5 area during recording.

OFF Select this setting if no signal assigned to CH5 is input.

Tacho Select this setting if a rotary pulse signal (tacho signal) is supplied to the rotary pulse input connector.

Voice Memo

Select this setting if the optional voice memo microphone is connected to the Voice Input connector and used for recording voice memos.

Marker Select this setting if the switch of the connected voice memo microphone is used for the marker function.

Voice memo recording is possible at the main screen, except when the setting is “OFF”.

HPF High-pass filter frequency setting

Enables a high-pass filter for the input signal. The HPF frequency indicates the cutoff frequency.

Available settings are OFF and 5 Hz.

When the Inp setting is DC, only the OFF setting is available for the high-pass filter.

OFF / 5 Hz

LPF Low-pass filter frequency setting

Enables a low-pass filter for the input signal. The LPF frequency indicates the cutoff frequency.

Available settings are OFF, 200 Hz, 1 kHz, and 2 kHz, but only selections that are within the frequency range setting are allowed.

OFF / 200 Hz / 1 kHz / 2 kHz

Available parameter list

Frequency range LPF	100 Hz	500 Hz	1 kHz	5 kHz	10 kHz	20 kHz
200 Hz	×	○	○	○	○	○
1 kHz	×	×	○	○	○	○
2 kHz	×	×	×	○	○	○

○ • • • Available

× • • • Not available

Sens Sensor type setting

Lets you select the sensor type and make other sensor related settings.
Available options depend on the Inp setting.

Inp setting	Available Sensor settings (depending on Inp) and description	
	Sens	Description
OFF	—	No setting available
AC/DC	V	Record input voltage from sensor or measuring instrument as is.
	EU	Convert input voltage from sensor or measuring instrument into EU for recording.
	SLM	Sound level meter (with AC or DC output) is connected.
	VM	Vibration level meter (with AC or DC output) is connected.
CCLD	V	Constant Current Line Drive compatible sensor is connected. Record input voltage from sensor as is.
	EU	Constant Current Line Drive compatible sensor is connected. Convert input voltage from sensor into EU for recording.
	MIC	Constant Current Line Drive compatible microphone is connected.
	PICK	Accelerometer with built-in preamplifier is connected.
VP4x	PICK	Accelerometer via charge converter VP-40 etc. is connected.

EU (Engineering Units) is a unit symbol for expressing various physical quantities detected by a sensor.

Sensitivity Unit conversion value setting

Specifies the relationship between input signal voltage and measurement value, according to the preceding Sensor type setting (Sens).

Sens setting	Sensitivity setting (depending on Sens)
V	No setting
EU	Voltage per EU (V/EU) (Note that the EU setting value is the inverse of that used in the DA-20.)
MIC	Constant Current Line Drive compatible microphone sensitivity level (dB)
PICK (CCLD)	Voltage sensitivity of accelerometer with built-in preamplifier [mV/(m/s ²)]
PICK (VP4x)	Charge sensitivity of accelerometer [pC/(m/s ²)]
SLM	Sound level meter level range (dB)
VM	Vibration level meter level range (dB)

For additional information on the Inp, Sens, and Sensitivity settings, see also pages 65 to 69.

<Rec.Parameters> menu

This menu comprises settings for recording and auxiliary functions.

MENU Rec. Parameters	
Frequency Range	20kHz
Sampling Frequency	x2.56
Bit Length	16 bit
Wave Splitting Interval	1 h
Recording Time	Manual
Pre Recording Time	0 s
Back⇐[MENU]	Exit⇐[STOP]
SD 1.9GB[001:10:25]	
2013/11/21 21:17:00	

Frequency Range Frequency range setting

The value selected as the frequency range setting represents the highest effective frequency that can be included in the recorded data.

Available settings are 100 Hz, 500 Hz, 1 kHz, 5 kHz, 10 kHz, and 20 kHz.

100 Hz / 500 Hz / 1 kHz / 5 kHz / 10 kHz / 20 kHz

Sampling Frequency Sampling frequency setting

The DA-21 provides a choice of two sampling frequency settings commonly used for frequency analyzers and voice processing: 2.4 times or 2.56 times the frequency range. FFT analyzers generally use 2.56 times.

x2.4 / x2.56

Bit Length Bit length setting

Select the recording data bit length. Increased accuracy of analysis and better sound quality can be obtained as the value increases. Available settings are 16 bit and 24 bit.

16 bit / 24 bit

Wave Splitting Interval Set splitting interval for recording data

Select the time interval at which the WAVE files recorded for channel 1 to 4 are to be split. The maximum number of WAVE files per recorded data set is 1000. Available settings are 10 minutes and 1 hour.

10 min / 1 h

Note

Rotary speed data and voice memo data recorded in channel 5 are not split.

Recording Time

Recording time setting

The recording time can be set in hours, minutes, or seconds, and a Manual setting is also available. When Manual is selected, the recording time is not preset, allowing the operator to press the [STOP] key whenever required. With the Manual setting, recording will automatically stop after 1000 hours have elapsed. A recording time that is longer than that available with the inserted SD memory card cannot be set.

The sub menu moves in the following order for the recording time (1 to 59 / 1 to 24 / Manual) and the unit (s, m, h).

When data for the preset recording time have been collected, recording stops automatically. However, if the [STOP] key is pressed before that, or if the SD memory card becomes full, recording stops at that point.

1 s to 59 s (seconds) / 1 m to 59 m (minutes) / 1 h to 24 h (hours) / Manual

Pre Recording Time

Pre-recording time setting

When recording is started by pressing the [REC] key or by a trigger event, the pre-recording function allows data from a range before the actual start point to be included in the recording. The Pre Recording Time value determines the duration of the range for such data. Available settings are 0 s, 1 s, and 5 s (seconds). To disable the function, select the “0 s” setting. For more information, refer also to page 76.

0 s / 1 s / 5 s

Note
After changing the frequency range or channel setting, the [REC] key will be inactive for the Pre Recording Time interval, and recording cannot be started during this interval.

<Trigger> menu

Comprises trigger related items (see pages 77 to 83).

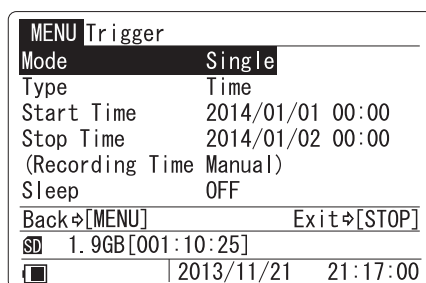
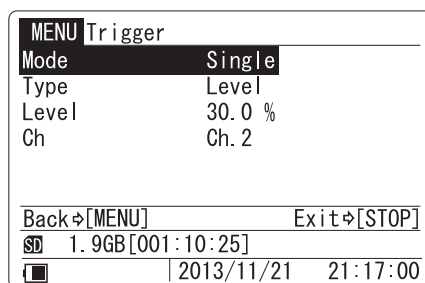
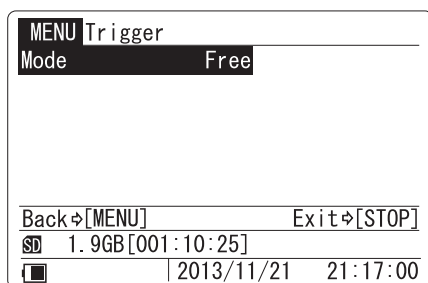

Mode Trigger operation mode setting

Determines the basic operation when a trigger event occurs. If trigger operation is not required, choose the “Free” setting.

- Free Trigger is not active. Recording starts immediately when the [REC] key is pressed.
- Single The unit goes into trigger standby mode when the [REC] key is pressed. When a trigger event occurs, recording starts. When the amount of data corresponding to the recording time has been recorded, recording stops.
- Repeat The unit goes into trigger standby mode when the [REC] key is pressed. When a trigger event occurs, recording starts. When the amount of data corresponding to the recording time has been recorded, the unit again goes into trigger standby mode. This is repeated with every trigger event until the [STOP] key is pressed or the SD memory card becomes full.
- Master If you synchronize two DA-21 units, the unit used as slave is selected this mode automatically.

Type Trigger signal type setting

Determines the type of trigger signal. When the “Mode” item is set to “Free”, this item does not appear.

Level A trigger event occurs and recording is started when the level of the input signal in the specified channel (trigger channel) becomes a preset value (trigger level) or higher.

External

A trigger event occurs and recording is started when the Ext. Trig. connector is shorted.

External Gate

Recording is carried out only while the Ext. Trig. connector is shorted (gate trigger operation). When the Ext. Trig. connector goes open, recording will stop after a delay of 5 seconds (post-recording).

Time Recording is carried out from the specified Start Time to the specified Stop Time, at intervals as specified by the Interval setting.

Level Trigger level setting

When the trigger signal type is “Level”, a trigger event occurs when the absolute value of the input signal waveform exceeds the trigger level. The trigger level is a threshold set as a relative percentage [%] correlated to the full-scale value of the input range setting that is active at the time of recording.

Consequently, the actual trigger level (input signal waveform value) will change when the input range setting is changed.

The trigger level is indicated on the bar graph for the trigger channel (see page 26).

Ch Trigger channel setting

When the trigger signal type is “Level”, a channel (1 to 4) must be specified for monitoring. This is called the trigger channel.

Start Time/Stop Time **Recording start time/stop time setting**

Lets you specify a start time and stop time for recording. These settings can span two different calendar years.

When the start time setting is before the current time, the setting automatically becomes “current time + 5 minutes”. When the stop time setting is before the current time, the setting automatically becomes “Start Time + 24 hours”.

Interval **Recording interval setting**

When the trigger signal type has been set to “Time” and the trigger mode to “Repeat”, the recording interval can be set here. The following settings are available.

5 m / 10 m / 15 m / 30 m / 1 h / 8 h / 24 h

Note
The interval setting must be longer than the “Recording Time” as set in <Rec.Parameters> menu.

Sleep Sleep function setting

When the trigger signal type is set to “Time”, this setting controls the use of sleep mode during recording.

OFF/ON

When sleep mode is ON, the unit goes into the power save state about 60 seconds after standby was activated by pressing the [REC] key. When Mode is set to “Repeat”, the unit will enter the power save state also between recording intervals.

In the power save state, the LCD screen is off.

About 90 seconds before recording start, the unit wakes up and goes into standby until the actual start.

Pressing the LIGHT key in the power save state temporarily turns on the LCD screen. If no further key is pressed, the unit will return to the power save state.

Operation example for sleep mode

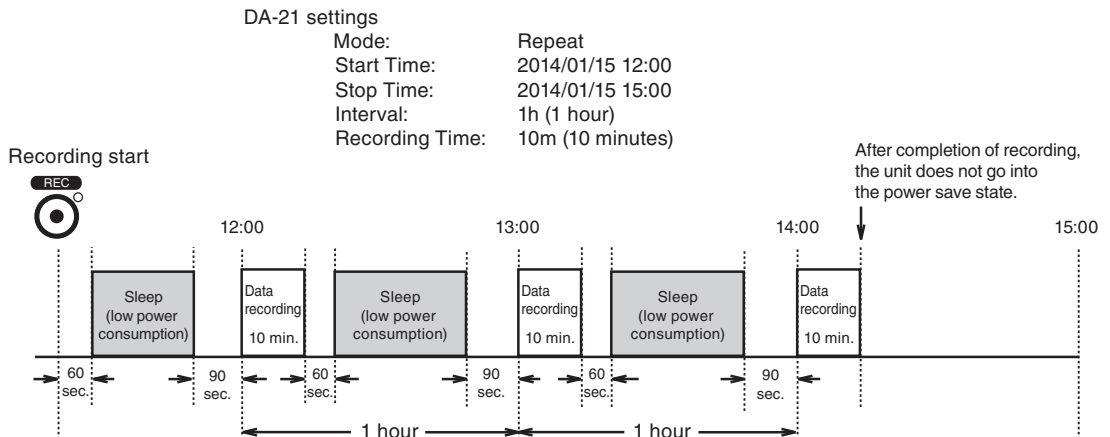

<Bar Graph> menu

This menu serves for making bar graph display settings.

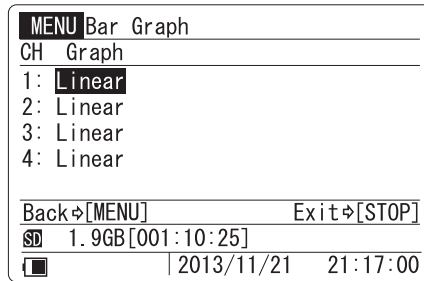

Graph Bar graph display method

Lets you select linear value display (Linear) or logarithmic value display (Log) for each channel.

For details on the bar graph display method, see page 27.

Linear / Log

Note

The Graph menu will be blank for channels whose “Sensitivity” has been set to MIC, SLM, or VM with <Input> menu. The bar graph indication for such channels is fixed to dB.

<System> menu

This menu comprises general items such as display backlight brightness and SD memory card data deleting.

MENU System	
Read / Save Setting	
Clock Settings	
Date	2013/12/03
Time	11:46:51
Backlight Settings	
Brightness	2
Back◀[MENU]	Exit▶[STOP]
SD 1.9GB[001:10:25]	
▣	2013/11/21 21:17:00

MENU System	
Backlight Settings	
Brightness	2
Auto Off	Continue
Battery Type	Alkaline
Card Format	
USB Storage	OFF
Back◀[MENU]	Exit▶[STOP]
SD 1.9GB[001:10:25]	
▣	2013/11/21 21:17:00

MENU System	
Battery Type	Alkaline
Card Format	
USB Storage	OFF
Monitor Out	ON
Index	1
Version	1.0
Back◀[MENU]	Exit▶[STOP]
SD 1.9GB[001:10:25]	
▣	2013/11/21 21:17:00

Read / Save Setting Read setting values from unit or SD memory card/Save setting values in unit or on SD memory card

MENU Read / Save Setting	
Load Default Settings	
Internal Memory	
No. 1	
No. 2	
No. 3	
No. 4	
Back◀[MENU]	Exit▶[STOP]
SD 1.9GB[001:10:25]	
▣	2013/11/21 21:17:00

MENU Read / Save Setting	
No. 1	
No. 2	
No. 3	
No. 4	
No. 5	
SD CARD	
Back◀[MENU]	Exit▶[STOP]
SD 1.9GB[001:10:25]	
▣	2013/11/21 21:17:00

Load Default Settings

Returns all unit settings to the initial (factory default) condition. In the <Read / Save Setting> menu, select “Load Default Settings” and press the [ENT] key. The execution choice screen appears.

Internal Memory (No. 1 to No. 5)

Input range and other settings made with the menus can be saved in the internal memory of the unit, allowing them to be easily read (reloaded) later. Five sets of settings identified as No. 1 to No. 5 can be saved. In the <Read / Save Setting> menu, select No. 1 to No. 5 for “Internal Memory” and press the [ENT] key. A screen to save or read settings appears. Use the [Δ]/[∇] keys to select the desired action and press the [ENT] key. The execution choice screen appears.

SD CARD

The input range and other settings made with the menus can be saved on an SD memory card for later use. Only one set of settings can be saved. The steps for saving and reading are the same as for “Internal Memory” described above. The setting file saved on the SD memory card can also be used as startup file for loading when the unit is turned on (see page 14). If the message “Card Error.” appears when you press the [ENT] key to update the setting file, the SD memory card may be defective.

Important

Changes to settings made with the menus will be saved on the SD memory card by the “Save Settings” function, but for the unit, the settings will only be activated at the point where you return to the main screen.

If you turn the power off before returning to the main screen, the changed settings will not be active the next time you turn the unit on.

Note

When a setting file is loaded which contains a CCLD setting for the Inp item of <Input> menu, the channels for which CCLD is selected will be supplied with a constant current.

If the unit is operated on battery power and the remaining capacity of the batteries is low, a forced power-down will occur when a CCLD setting is selected (see page 40).

Clock Settings**Current date and time setting****Date**

Select “Date” and press the [ENT] key. Set the year (to 2037), month, and day separately on the displayed sub menu.

Time

Select “Time” and press the [ENT] key. Set the hours, minutes, and seconds separately on the displayed sub menu.

Backlight Settings**Backlight brightness and auto off time setting****Brightness**

Select the grade of backlight brightness from the number of 1 to 4.

Auto-Off

When no key is operated for the period set here, the backlight will be automatically turned off. Available settings are 30 s (seconds), 3 m (minutes), and Continue. To have the backlight continuously on, select Continue.

Battery Type**Used battery type setting**

Displays the sub menu to select the type of battery used for the unit. The remaining battery capacity corresponding to the selected battery is displayed on the main screen. Available settings are Alkaline and Ni-MH (nickel-metal hydride).

Alkaline / Ni-MH

Card Format**SD card formatting**

Formats the inserted SD memory card.

Select “Card Format” and press the [ENT] key. The execution choice screen appears.

USB Storage**Function setting for connection to computer**

When set to “ON”, connecting the unit to a computer via USB will cause the SD memory card inserted in the unit to be recognized as a removable disk. Data recording and data recall operation cannot be performed when the state of “USB Storage” is set to “ON”.

Monitor Out **Function setting for Monitor Out connector**

When set to “ON”, a playback signal for the monitor channel is output from the Monitor Out connector.

For details about playback, refer to the section beginning on page 111.

Index **Device index number setting**

Using this setting, you can assign a unique number to each DA-21 device. The setting range is 1 to 255. Because the index number information is recorded along with the data, it can be used to identify multiple DA-21 units or data recording conditions.

The index number setting has no influence on performance or functions of the unit.

Version **Version information**

Displays the firmware version of the unit.

<Synchronization> menu

Contains settings for operating two connected DA-21 units as a synchronized system.

For additional information on DA-21 synchronized operation, also refer to page 91.

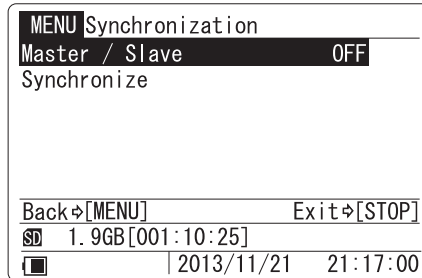

Master / Slave Assign unit to master or slave operation

After connecting two DA-21 units, this setting determines whether the respective DA-21 unit operates as master or as slave.

- OFF No synchronized operation.
- Master Select this setting on the DA-21 to be used as master.
- Slave Select this setting on the DA-21 to be used as slave.

Synchronize Synchronize connected DA-21 units

Use the dedicated cable to connect the two DA-21 units to be used as master and slave. Select this item on both units and press the [ENT] key. The execution choice screen appears. Then press the [ENT] key on both unit simultaneously. Two connected DA-21 units synchronize.

Important
Establish the same settings on both DA-21 units (<Rec.Parameters> menu items). If settings are different, synchronized operation is not possible. Also, when the settings are changed after the synchronization, it is necessary to synchronize again.
Check the synchronization information on the display (page 18) after operation of the synchronization.

Preparations

This chapter describes the settings and steps to take before starting to record data.

Preparations and checks before recording

1. Power supply (inserting batteries, AC adapter, wake-up-on-power mode)
2. SD memory card preparations (insertion and removal, formatting)
3. Connection of external devices (sensors etc.)
4. Sensitivity setting

Recording parameter settings

1. Input range, overload
2. Frequency range, sampling frequency
3. Recording time, trigger

Auxiliary function setup

1. Device index number
2. Voice memo/marker
3. Preventing inadvertent operation
4. Remote control operation
5. Connection to a computer
6. Inter-unit synchronization
7. Tachometer signal input

Preparations and checks before recording

Power supply

The DA-21 can be powered from four IEC LR6 (size AA) batteries or from the optional AC adapter NC-98 series.

Important

Use only the specified AC adapter available as an option for the DA-21.

Inserting the batteries

1. Open the battery compartment cover.
2. Insert four IEC LR6 (size AA) batteries with correct polarity, as shown inside the compartment.
3. Replace the battery compartment cover.

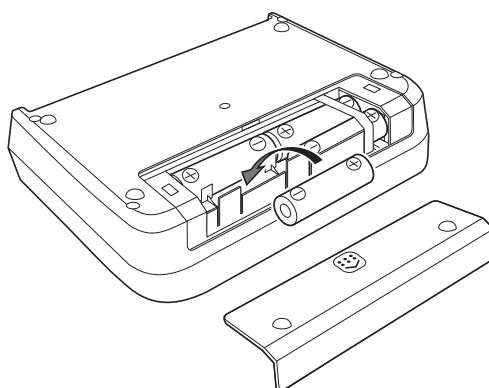

Important

Take care not to reverse the (+) and (–) polarity when inserting the batteries. Always replace all four batteries together. Do not mix old and new batteries or batteries of different type. Remove the batteries from the unit if the unit is not to be used for an extended period.

Note

If the unit is operated on battery power, take the following points into account when using a CCLD type sensor. When quitting the menu after setting the “Inp” item of <Input> menu to CCLD, the unit may switch itself off automatically. In such a case, replace all batteries with fresh ones.

Connecting the power cord and AC adapter (option)

Connect the AC adapter as shown below. Turn the unit off before making this connection.

1. Plug one end of the power cord into the small socket on the AC adapter.
2. Insert the plug of the supply cable from the AC adapter into the DC IN connector on the DA-21.
3. Plug the other end of the power cord into an AC outlet.

To remove the AC adapter, turn the DA-21 off and then perform the above steps in reverse order.

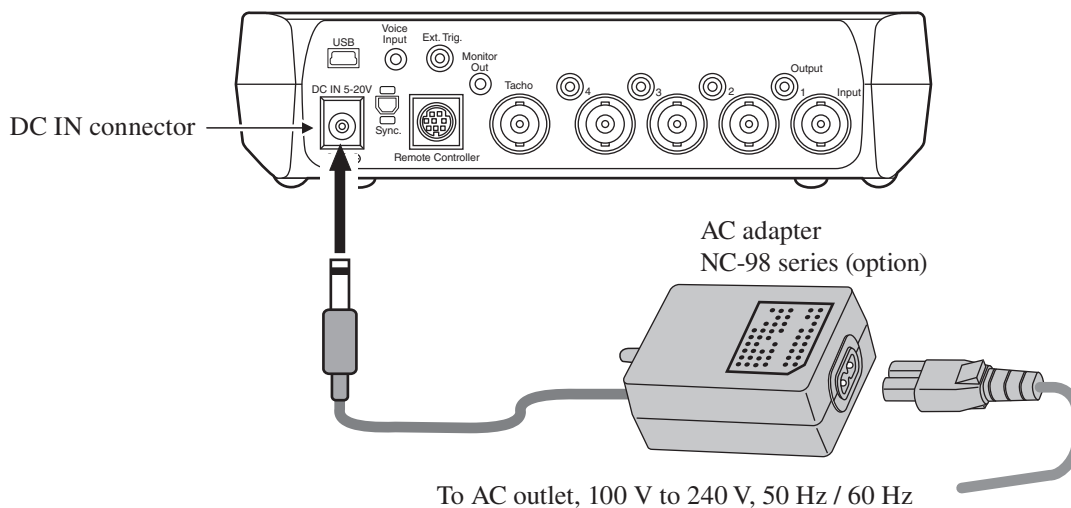

Important

Use only the specified AC adapter available as an option for the DA-21. Using another kind of AC adapter may lead to damage and malfunction. When connecting a battery or purpose-built cable to the DC-IN connector, take great care to ensure correct polarity and voltage.

Backup battery

The unit uses a backup battery (rechargeable battery) to operate the clock.

While power to the unit is on, the backup battery will be charged. It will also be charged while power to the unit is off if external power is connected.

The relationship between charging time and retention period is shown below.

A full charge of the backup battery is achieved after 24 hours.

Charging time	Retention period
1 hour	2 days
12 hours	30 days
24 hours	45 days

Use the AC adapter when connecting external power for battery charge while the unit is turned off. The service life of the backup battery is limited. You should have the battery replaced about once every five years. Please contact your supplier.

Note
The charging time, retention period and service life of the backup battery may vary depending on the operating condition.
When the backup battery is old, the retention period will be shorter.

Wake-up-on-power mode

When you open the battery compartment cover as shown below, the [WAKE UP ON POWER] switch becomes accessible. By setting this switch to ON, you can have the on/off status of the unit controlled by the power supplied to the DC-IN connector. In such a case, the [POWER] key on the panel has no effect.

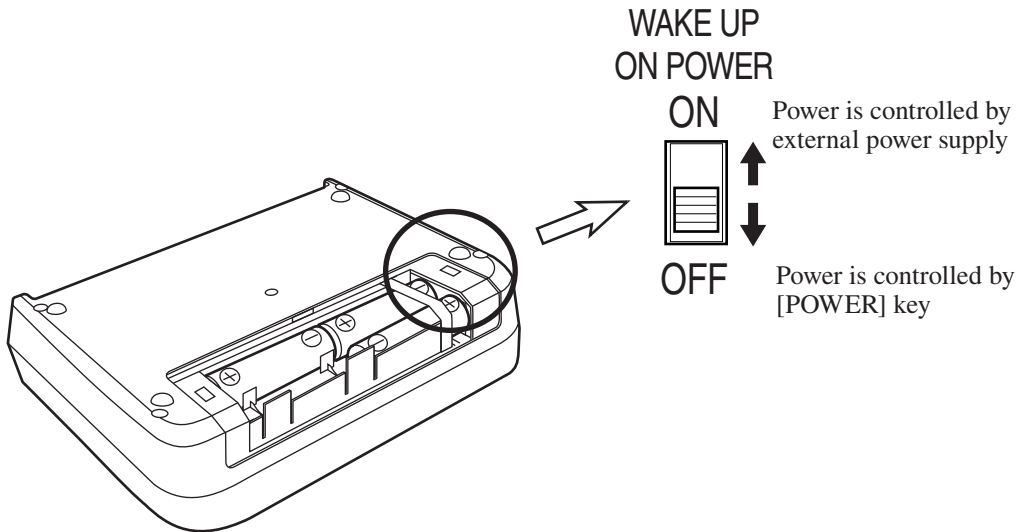

Important

When setting the [WAKE UP ON POWER] switch to ON, remove all batteries from the battery compartment. Otherwise the wake-up-on-power mode will not operate normally.

Remove the batteries from the unit if it is to be stored for a long time with the [POWER] key set to OFF to prevent possible damage caused by battery leakage.

SD memory card preparations

Recorded data are stored on SD memory cards in WAVE file format.

To store the data in files, a dedicated folder structure and a data management file are required on the card. These are created automatically when the SD memory card is used for the first time. Depending on the setting for recording data, multiple WAVE files may be created (see page 116).

An SD memory card inserted in the unit will be recognized as a removable disk by the computer when the “USB Storage” item of <System> menu is set to “ON”, without having to install a USB driver.

For connection to the DA-21 and the computer, use an optional (generic) A - mini B USB cable.

Important
SD memory cards even from the same manufacturer and of the same type exhibit certain variations in specifications which may cause problems. For this reason, be sure to use only the SD memory cards provided by Rion. The performance of other cards is not guaranteed.
This unit supports SD memory cards and SDHC memory cards, but not SDXC memory cards.
Format the SD memory card by the DA-21 before recording.
If folders or files on the SD memory card have been altered by other equipment except the DA-21, do not continue to use the card for recording in the DA-21. Data may not be recorded correctly.

Inserting and removing an SD memory card

Important
Make sure that power is OFF before inserting or removing a card.
Take care to insert the SD memory card with correct orientation.
If the SD memory card is removed while data is being read or written to the card, the data may be destroyed.
Note that we assume no responsibility for any damage or loss of stored measurement data.

1. Open the card slot cover of the unit.
2. Insert the SD memory card into the card slot with the label of the card facing up. Push the card in until it is locked in place.
3. To remove the card, push the card a bit further in, the card is released and pops out of the card slot.

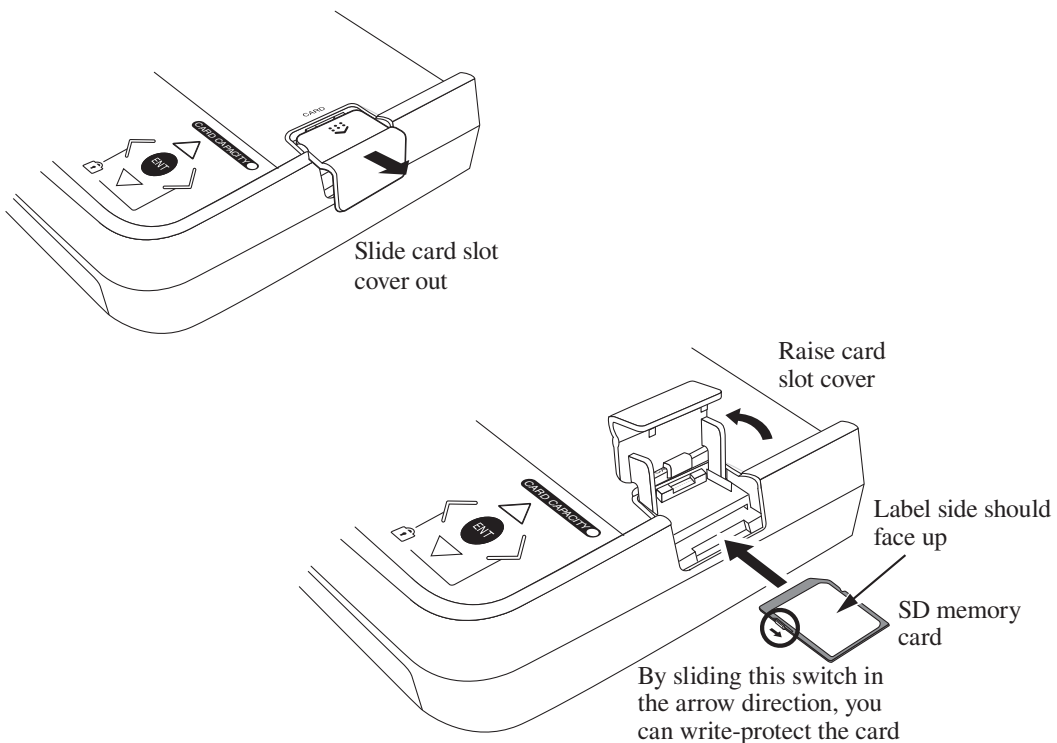

Formatting an SD memory card

Note
When an SD memory card is formatted (initialized), all data present on the card will be lost. But the setting file will remain if the card is formatted by this unit.

In the following cases, you should format the SD memory card:

- When using the SD memory card in the unit for the first time
- When wishing to delete all data from the SD memory card

To format an SD memory card, proceed as follows.

1. Select “Card Format” on the <System> menu and press the [ENT] key.
2. The execution choice screen appears. Press the [ENT] key.

External equipment (sensor etc.) connections

As shown below, the DA-21 is designed to handle the output of various sensors or measuring instruments. Correct input settings must be made, depending on the sensor and signal type and whether the sensor requires a constant current power supply. Some possible combinations are shown below.

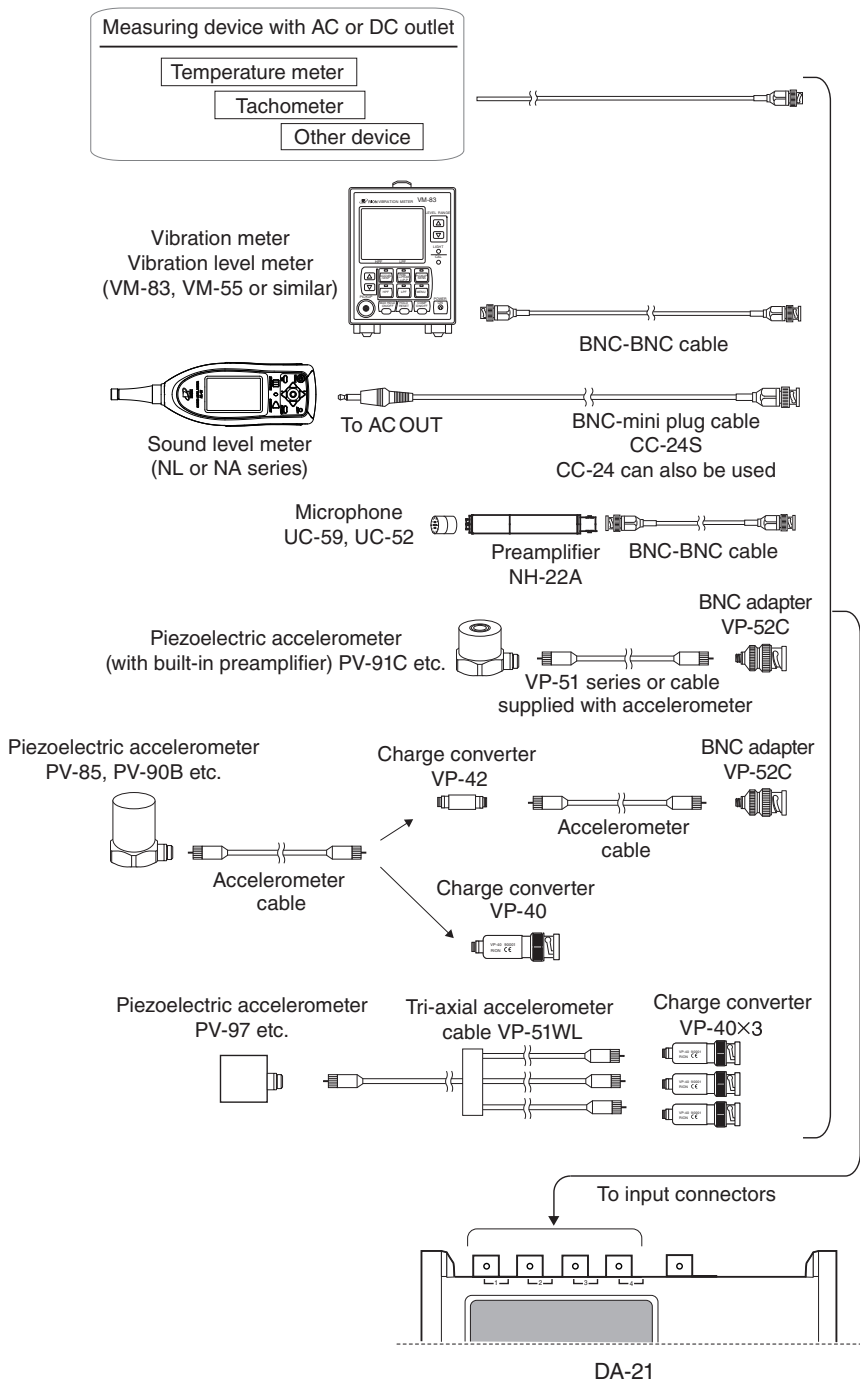

Input settings

The four signal input connectors (BNC connectors) can not only accept a signal, they also allow output of a constant current to a CCLD (Constant Current Line Drive) type sensor. Some CCLD sensors use a basic preamplifier + accelerometer or microphone configuration. The DA-21 can record up to four input signals. The input connectors 1 to 4 are assigned to channels 1 to 4.

Input setting (<Input> menu: Inp)

The setting is made for each channel separately, with the “Inp” item on <Input> menu.

- AC For sensors that output an electrical signal without DC components
DC components and components 0.3 Hz or below are blocked.
Example: AC output of sound level meter or vibration meter
- DC For sensors that output an electrical signal including DC
Example: Temperature meter or tachometer output, DC output of sound level meter
- CCLD For sensors requiring a constant current source
For such sensors, a constant current is supplied via the input connectors of the DA-21.
Example 1: Combination of microphone UC-52 or UC-59 or similar with preamplifier NH-22A (CCLD: 2 mA) or similar
Example 2: Piezoelectric accelerometer with built-in preamplifier PV-91C, PV-97I (3-axis) or similar
- VP4x Sensor connected via the charge converter VP-40
Example: Accelerometer PV-85 or PV-90B etc. connected via the charge converter VP-40

Sensitivity setting (<Input> menu: Sens, Sensitivity)

Sensor setting

Depending on the input setting described on the preceding page (AC, DC, CCLD, VP4x), set the “Sens” item for the combinations marked with a “○” in the table below. EU (Engineering Units) is a unit symbol for expressing various physical quantities detected by a sensor.

Inp \ Sens	V	EU	MIC	PICK	SLM	VM
AC	○	○	×	×	○	○
DC	○	○	×	×	○	○
CCLC	○	○	○	○	×	×
VP4x	×	×	×	○	×	×

When the “Sens” item is set, the sensor signal units are determined automatically, as shown in the table below.

Indication for Sensor item in menu	Unit as shown on main screen	Scaled unit set for Sensitivity item in menu	Value input for Sensitivity
—	V	—	—
EU	EU	V/EU	Set voltage corresponding to 1 EU
MIC	dB	dB	Set microphone sensitivity level (dB re. 1 V/Pa)
PICK (CCLD)	m/s ²	mV/(m/s ²)	Set sensitivity of accelerometer (with built-in preamplifier)
PICK (VP4x)	m/s ²	pC/(m/s ²)	Set charge sensitivity of accelerometer
SLM	dB	dB	Set sound level meter level range (full-scale value)
VM	dB	dB	Set vibration level meter (VM-55 or similar) level range (full-scale value)

Sensitivity setting

This setting determines the correlation between input signal voltage and signal units. How the values are to be set for each signal unit is explained below.

mV/(m/s²) Set the voltage sensitivity of the accelerometer.
 Example: For PV-90I rated for 0.44 mV/(m/s²), the setting should be “0.44”.

dB Set the microphone sensitivity level (dB re. 1 V/Pa), or level range (full-scale value) of sound level meter or vibration level meter.

Microphone

Example: For UC-53A rated for -28 dB and used together with NH-22A, the transmission loss is taken as -0.5 dB and the setting should therefore be “-28.5”.

Sound level meter

Set to full-scale value of level range

Example: 80 dB

Vibration level meter

Set to full-scale value of level range

Example: 80 dB

EU Set how many volts of the sensor signal voltage correspond to one unit of the physical quantity.

Example: For a tachometer rated for 1 V/1000 rpm, the setting should be “1.00E-03”.

The table below shows the correlation formula for the original input range X [V] and the condition after the sensitivity setting.

Unit	Sensitivity value	Inp (Sens) type	Input range value after conversion
[V]	None	DC/AC(---)	$X[V]$
[EU]	$K[V/EU]$	DC/AC(EU)	X/K
[dB]	$S[dBV/Pa]$	MIC(CCLD)	$94-S-3+20 \log_{10}(X)$
[m/s ²]	$V[mV/(m/s^2)]$	PICK(CCLD)	$1/(V/1000) \times X$
	$V[pC/(m/s^2)]^*$	PICK(VP4x)	
[dB]	$R[dB]$	SLM/VM	$20 \log_{10}(X)+R-10$

* Take the charge sensitivity [pC/(m/s²)] given in the calibration certificate of the accelerometer and enter it as voltage sensitivity [mV/(m/s²)].

Some practical examples for applying the respective formula to actual sensitivity values are shown below. These values are shown as input range. (When the exponent is two digits, the mantissa is shown as one digit. The effective number of digits for dB is three. In 3-V systems, $\sqrt{10}$ is used instead of 3 for calculation. This is because the 3-V range actually is 3.16 V) = $\sqrt{10}$.)

Sensor	Sensitivity	Unit	Actually displayed input range value						
			10 V	3 V	1 V	0.3 V	0.1 V	0.03 V	0.01 V
General	1	V	10 V	3 V	1 V	0.3 V	0.1 V	0.03 V	0.01 V
Tachometer	$K=1.0E-03$	EU	1.00E+4	3.16E+3	1.00E+3	3.16E+2	1.00E+2	3.16E+1	1.00E+1
UC-59	$S=-28.5$	dB	139.5 dB	129.5 dB	119.5 dB	109.5 dB	99.5 dB	89.5 dB	79.5 dB
PV-90I	$V=0.44$	m/s ²	2.27E+4	7.19E+3	2.27E+3	7.19E+2	2.27E+2	7.19E+1	2.27E+1
SLM	$R=80 \text{ dB}$	dB	90	80	70	60	50	40	30

Input settings and sensitivity settings for some representative sensors are shown below for reference. The sensitivity value differs for each sensor.

Sensor example	Inp	Sens	Sensitivity	Sensor sensitivity unit
DC output of general measuring device or sensor, or AC output of vibration meter	DC	----	No setting	1
		EU	X.XXE+XX	V/EU
AC output of general measuring device, sensor, vibration meter, sound level meter	AC	----	No setting	1
		EU	X.XXE+XX	V/EU
Microphone: UC-52 + Preamplifier: NH-22A	CCLD	MIC	Sensitivity level (-0.1 to -99.9)	dB (0 dB=1 V/Pa)
Piezoelectric accelerometer (with built-in amplifier):PV-90I	CCLD	PICK	Voltage sensitivity (0.01 to 99.9)	mV/(m/s ²)
Piezoelectric accelerometer: PV-85 + Charge converter: VP-40	VP4x	PICK	Charge sensitivity (0.01 to 99.9)	pC/(m/s ²)
Sound level meter NL series	AC	SLM	Voltage sensitivity (40 to 140)	dB
Vibration level meter:VM-55	AC/DC	VM	Voltage sensitivity (40 to 140)	dB

Note

When Inp is set to AC, a high-pass filter with a cutoff frequency of 0.3 Hz is applied. However, if the input signal contains high-level DC components that exceed the input range, overload may occur in the DA-21.

Recording parameter settings

This section describes how to set the parameters for recording data. Input range, frequency range, sampling frequency, and recording time are required items. If necessary, you should also set the Pre Recording Time, trigger, and other related items.

Input range setting

The input range can be set to seven levels in 10 dB steps (0.01 V, 0.03 V, 0.1 V, 0.3 V, 1 V, 3 V, 10 V). Select an appropriate setting according to the input signal level and the operation method of the DA-21.

For improved S/N ratio, setting the input range as low as possible without causing overload is generally preferred. For inspection of products and other kinds of periodic measurements, it may be necessary to keep the input range setting the same, in order to allow product comparisons and to detect deterioration over time.

To set the input range, proceed as follows from the main screen.

(The setting cannot be changed in recording or recall mode.)

1. Activate cursor in input range display section

Press the [RANGE] key to cause the input range display section to be shown in reverse (cursor active).

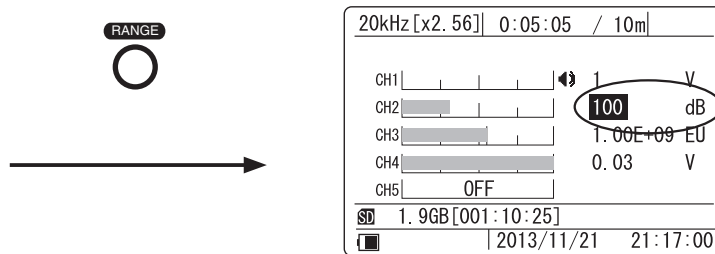

2. Select the channel for which to change the input range

Use the [Δ]/[∇] keys to move the cursor to the channel whose input range setting you want to change.



3. Activate the range change mode.

Press the [ENT] key to bring up the sub menu.

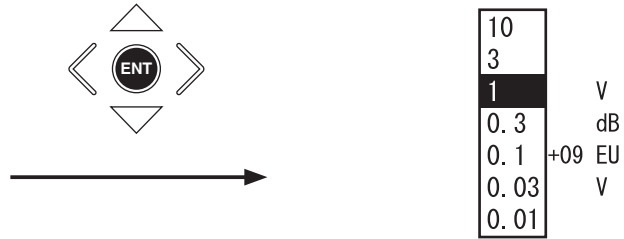

4. Select the new input range setting.

Use the [Δ]/[▽] keys to change the input range.



5. Confirm the new input range setting.

Press the [ENT] key to return to the condition of step 2.



6. If you want to change the input range for another channel, repeat the procedure from step 2. Otherwise press the [RANGE] key to complete the range setting procedure.

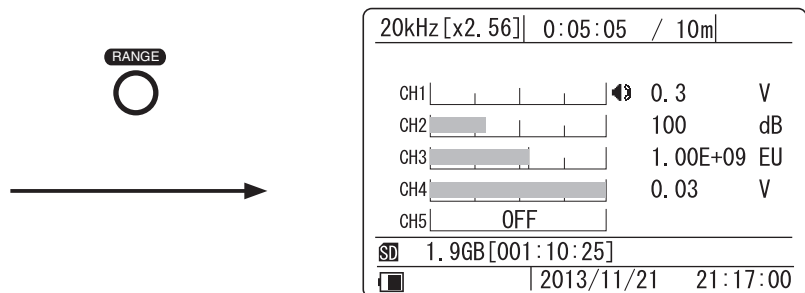

Input range setting and overload

When setting the input range, check whether overload occurs. When this happens, the overload indicator on the front panel lights up in red, and the indication **OVER** appears on the display.

To improve reliability and ensure that overload does not occur for an extended period, the overload history indication is convenient. This indication comes on when there has been an overload event at any time within a given period. To reset the indication, hold down the [CLEAR Ov] key. When the key is released, overload history monitoring **OVER** begins, allowing the operator to determine later whether there has been overload without having to constantly check the overload indicator.

The overload history is also cleared when you make a recording parameter setting. For details on clearing the overload history, see page 24 (Overload Information).

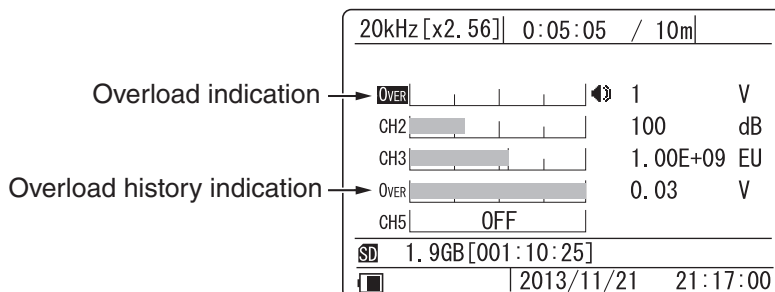

Sampling

The sampling action of the DA-21 is controlled by the frequency range and sampling frequency setting. The sampling frequency can be set to 2.4 times or 2.56 times the frequency range.

Setting the frequency range

The frequency range can be set in six steps (100 Hz, 500 Hz, 1 kHz, 5 kHz, 10 kHz, 20 kHz). Make the setting using the “Frequency Range” item in <Rec.Parameters> menu.

The frequency range value represents the highest effective frequency that will be included in the recorded waveform. Higher components will be cut off. When making the setting, choose a value that is higher than the highest frequency of components that need to be included in the recorded data.

Setting the sampling frequency

Waveform sampling is carried out at a frequency that is 2.4 times or 2.56 times the frequency range value. Make the setting using the “Sampling Frequency” item in <Rec.Parameters> menu.

To perform FFT analysis after recording, using the $\times 2.56$ setting is recommended.

Recording process

When you press the [REC] key, the data recording operation starts. However, if the trigger function (described later) is used, recording may not begin right away. In such a case, actual recording will only start when the trigger conditions are met, or in other words when a trigger event occurs.

Recording stops when the amount of data corresponding to the recording time has been recorded. If repeat trigger is selected, the recording condition is not terminated at this point. Rather, the unit goes into trigger standby mode and recording begins again at the next trigger event.

Even before the amount of data corresponding to the recording time has been recorded, recording can be stopped by pressing the [STOP] key. It will also stop when the SD memory card becomes full. Data recorded up to that point will be stored.

Setting the recording time

The recording time can be set to 1 s to 59 s (seconds), 1 m to 59 m (minutes), 1 h to 24 h (hours), and a “Manual” setting is also available. When “Manual” is selected, recording continues until the [STOP] key is pressed. Regardless of the recording time setting, when there is no more room on the SD memory card to store data (remaining recording time is about 10 seconds), recording stops. Recording to one file is also limited to a maximum of 1000 hours. When this limit is reached, recording stops.

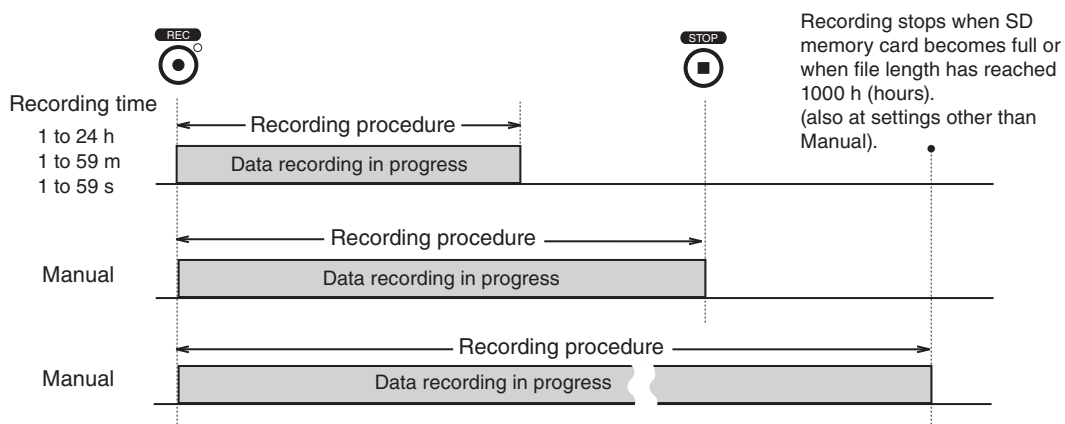

Make the recording time setting using the “Recording Time” item in <Rec. Parameters> menu.

When the “Pre Recording Time” has been set to 1 second, the recording time can be set to a value of 2 seconds or higher. When the “Pre Recording Time” has been set to 5 seconds, the recording time can be set to a value of 6 seconds or higher.

The recording time setting cannot exceed the remaining available capacity of the SD memory card inserted in the DA-21. If this applies, the recording time will automatically be changed to the maximum available time when the [ENT] key is pressed.

Setting the Pre Recording Time

If you wish to include data from a point slightly before the [REC] key was pressed or before the trigger event, use the Pre Recording Time function. Available pre-recording settings are 0, 1, and 5 seconds.

The overall recorded data length will correspond to the recording time. The Pre Recording Time is not added to the recording time, rather it is included in the total.

Make the Pre Recording Time setting using the “Pre Recording Time” item in <Rec.Parameters> menu (page 45).

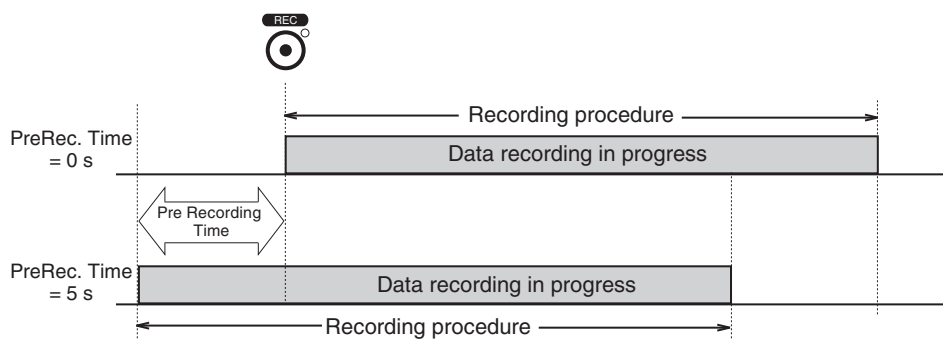

Difference in recording procedure with Pre Recording Time

(Pre Recording Time: 5 s, Recording Time: other than Manual, Trigger Mode: Free)

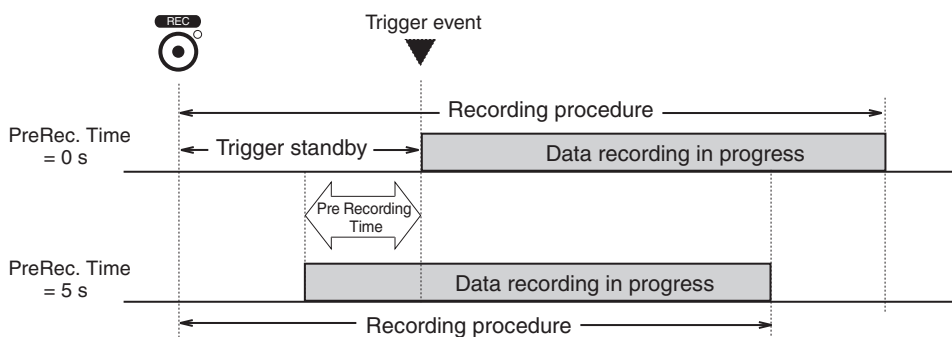

Difference in trigger operation depending on Pre Recording Time setting

(Pre Recording Time: 5 s, Recording Time: other than Manual, Trigger Mode: Single)

When the “Type” item of <Trigger> menu is set to “Time”, the Pre Recording Time setting has no effect.

Trigger conditions

The trigger operation is determined by the trigger mode and trigger type. When the trigger type is set to “Level”, the trigger level and trigger channel must be set. For the “Time” trigger the start/stop time and interval must be set. Only trigger events that occur while the DA-21 is in the trigger standby condition are valid. Any trigger events that occur while data recording is in progress are disregarded.

Setting the trigger mode

This setting determines the basic triggering operation.

Make the trigger mode setting using the “Mode” item in <Trigger> menu.

If the trigger function is not required, select the “Free” setting.

Free (trigger off)

Recording starts immediately when the [REC] key is pressed and ends when the amount of data corresponding to the recording time has been recorded.

Single (single trigger)

The unit goes into trigger standby mode when the [REC] key is pressed. When a trigger event occurs, recording starts. When the amount of data corresponding to the recording time has been recorded, recording stops.

Repeat (repeat trigger)

The unit goes into trigger standby mode when the [REC] key is pressed. When a trigger event occurs, recording starts. When the amount of data corresponding to the recording time has been recorded, the unit again goes into trigger standby mode and the operation is repeated.

Note
Repeat setting is possible also when the Recording Time is set to Manual. But the trigger operation is carried out only once.

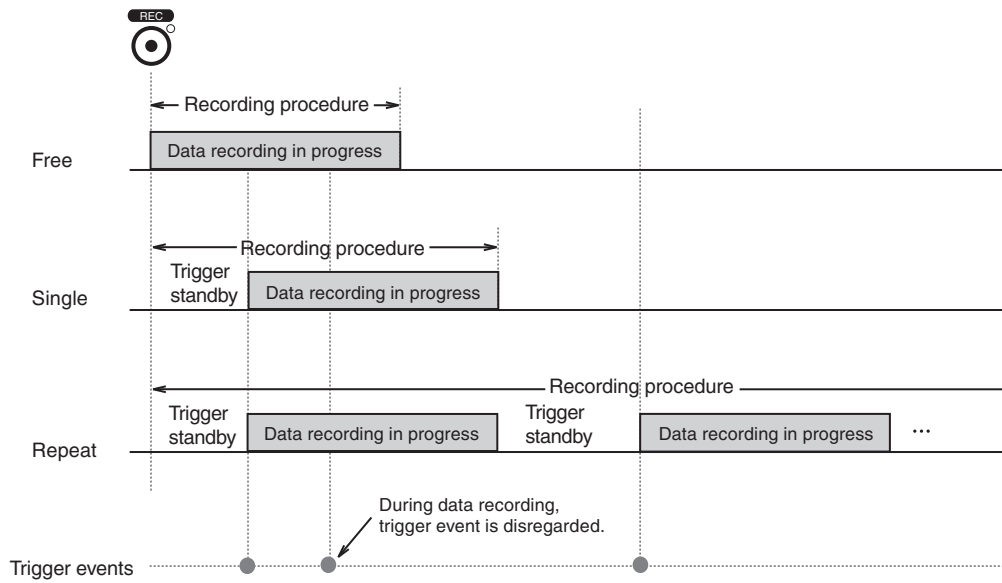

Difference in recording procedure according to trigger mode

(Pre Recording Time: 0, Recording Time: other than Manual, Trigger Type: Level or External)

Setting the trigger type

This setting determines the type of event that serves as a trigger.

Make the setting using the “Type” item in <Trigger> menu.

Level (level trigger)

A trigger event occurs when the level of the input signal in the specified trigger channel becomes equal or higher than a preset threshold value (trigger level).

Note
<ul style="list-style-type: none">• Delay of the record start time which recognized by the AC input signal when the trigger type is “Level” <p>If the input signal reaches a trigger level, recording will be started from the point of time. However, with the cause of data processing of DA-21, the recording is started later than the time which fulfilled trigger conditions.</p> <p>If you want to record all the waveforms which fulfilled trigger conditions, set the “Pre Recording Time” in <Rec.Parameters> menu as 1 second or 5 seconds.</p>

External (external trigger)

A trigger event occurs when the state of the Ext. Trig. connector changes from H (open) to L (shorted). Detection is carried out on the falling edge.

External Gate (external gate trigger)

Data recording is carried out while the state of the Ext. Trig. connector is L (shorted). Also after the state changes to H (open), recording continues for five seconds (post-recording). If the state of the Ext. Trig. connector is already L (shorted) when the [REC] key is pressed, recording starts straight away because the trigger conditions are met. With this trigger type, the recording time setting has no effect.

Time

Recording is carried out from the specified Start Time to the specified Stop Time, at intervals as specified by the Interval setting.

Note

The “Pre Recording Time” setting in <Rec.Parameters> menu has no effect. When the Stop Time is reached, recording will stop, also if the Recording Time is not yet completed.

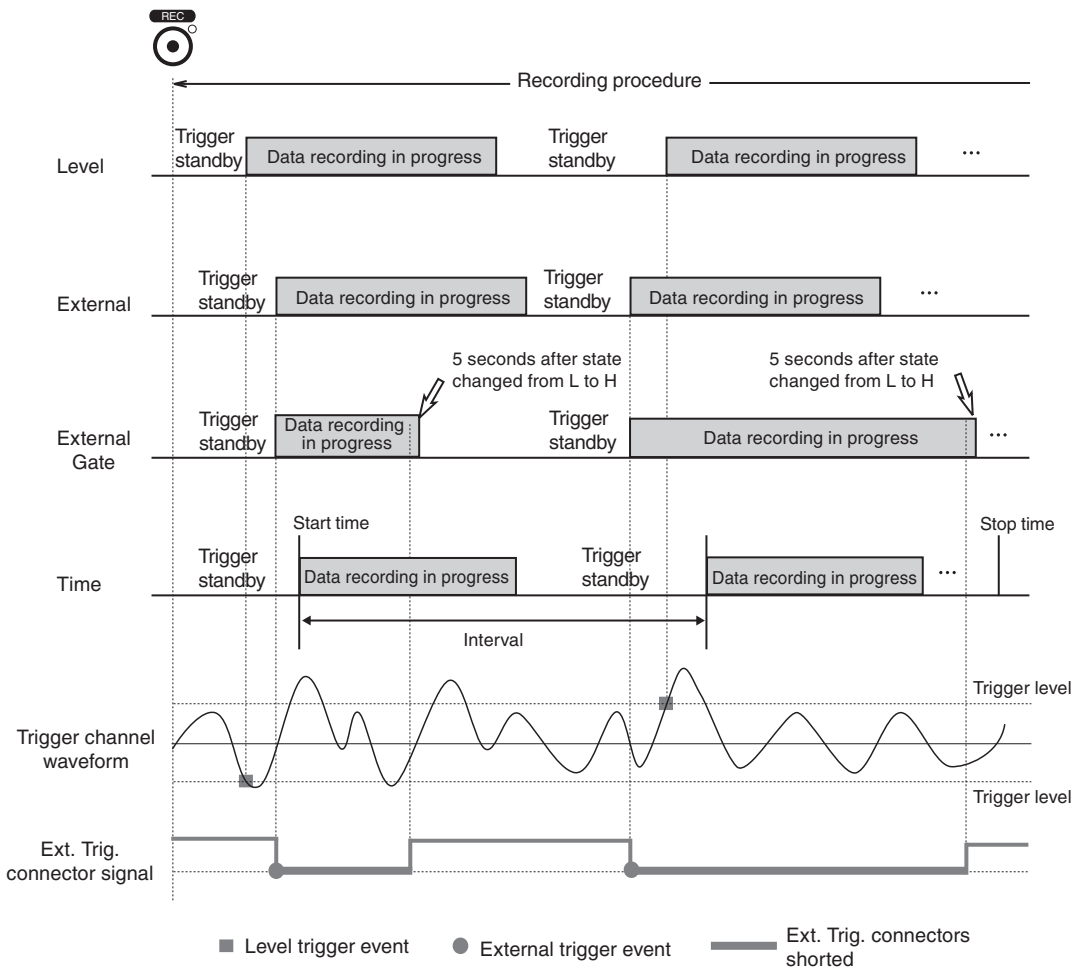

Difference in recording procedure according to trigger type

(Pre Recording Time: 0, Recording Time: other than Manual, Trigger Mode: Repeat)

Setting the trigger level

When the trigger type is set to “Level” (level of signal at input connector), the actual level to be used as a trigger level must be set as a percentage [%] of the full-scale value of the current input range.

Make the setting using the “Level” item in <Trigger> menu. The actual trigger level is indicated on the bar graph for the trigger channel (see page 26).

Setting the trigger channel

When the trigger type is set to “Level”, the channel to be used as trigger channel must be set.

Make the setting using the “Ch” item in <Trigger> menu.

The indication “TRG” is shown at the left of the trigger channel. (For information on level trigger target channel indication, see page 24).

Setting the start and stop time

When the trigger type is set to “Time”, set the start time and stop time as follows.

Make the setting using the “Start Time” and “Stop Time” items in <Trigger>.

Note
When the start time setting is before the current time, the setting automatically becomes “current time + 5 minutes”. When the stop time setting is before the current time, the setting automatically becomes “Start Time + 24 hours”.

Setting the recording interval

When the trigger mode is set to “Repeat” and the trigger type is set to “Time”, set the interval as follows.

The interval setting cannot be shorter than the Recording Time setting. Make the setting using the “Interval” item in <Trigger> menu.

When Stop Time is reached before Recording Time is up

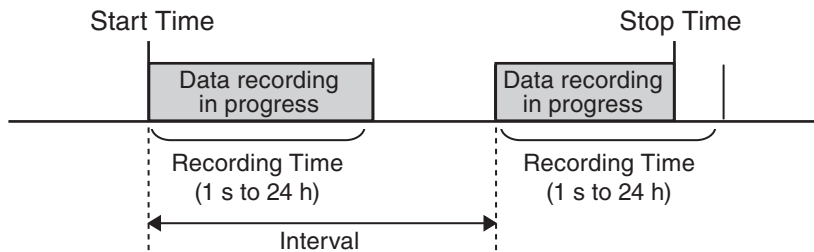

Recording stops (Stop Time has priority)

When Recording Time is set to Manual, recording stops at the Stop Time

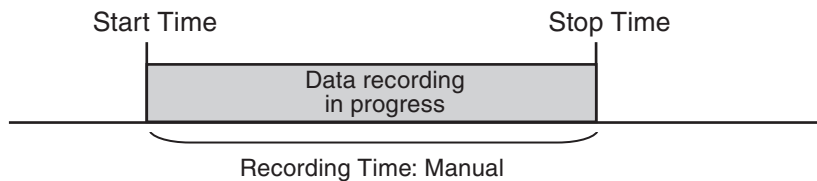

Recording begins at the specified start date/time and ends at the specified stop date/time.

Repeat trigger precaution

If trigger conditions are met while a file is being closed, the next recording will not start.

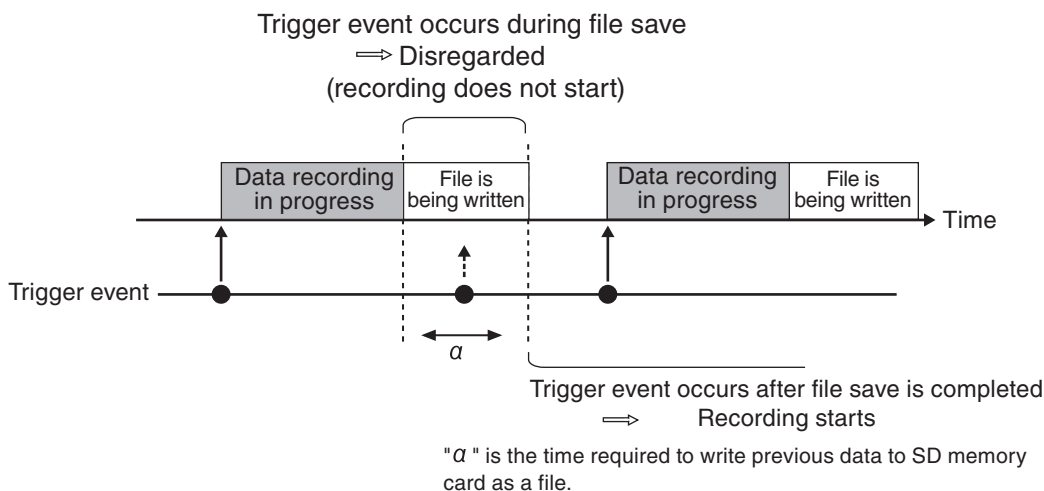

File write time

Recorded data are also written sequentially to a file during the recording process, but at the point where recording stops, there will be a certain amount of data that still need to be written. In addition, file management information to allow later retrieval of the file also needs to be created. The “File is being written” message refers to this process of writing remaining data and file management information. The following message appears on the display during the process (see page 125).

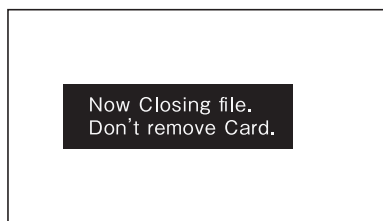

Auxiliary function setup

Device index number (<System> menu: Index)

The index number setting has no influence on performance or functions of the unit. Setting an index number is optional. The setting range is 1 to 255. Some possible uses for the index number capability are listed below.

1. Temporary management (classification) of recorded data

Example 1 In a system where several DA-21 units are used, the index number can serve to manage data according to the unit on which the data were recorded.

Example 2 Manage recorded data according to measurement purpose, measurement location, or similar.

Example 3 Manage recorded data according to measurement parameters.

2. Using the index number as input range information

When using a system where a calibration signal is recorded in order to calibrate recorded data, sensor range information will be required. Using an input range value as the index number will facilitate data management.

Example Set the index number to 120 when a sound level meter is calibrated in input range 120 dB.

Voice memo/marker

The voice memo function allows the operator to add comments before and after the recording procedure or during recording. The marker function can be used to mark a certain position, for example when a particular phenomenon occurred during recording. This makes it easy to later locate the data for that point. For example, if noise was encountered at a certain point, the marker can serve to locate and isolate the corresponding data.

Voice memo

While voice memo is activated, the sound picked up by the voice memo microphone connected to the Voice Input connector can be recorded. When the “Inp” item for CH5 in the <Input> menu is set to “Voice Memo”, the indication **VO** appears to the right of the bar graph.

The level of the voice signal is shown by the bar graph for channel 5. Pressing the switch on the voice memo microphone activates voice memo recording. Releasing the switch stops voice memo recording.

Marker

The marker function is only available during data recording. The maximum number of marker points that can be set between the beginning and the end of data recording is about 3,000.

When the “Inp” item for CH5 in the <Input> menu is set to “Marker”, the indication **MK** appears to the right of the bar graph.

When the microphone switch is pressed, the indication **MK** flashes for one second.

The marker precision is about 1 second.

Comparison of voice memo and marker operation

The diagram below illustrates the operation principle of the voice memo and marker function. The functions differ in the action that occurs when the microphone switch is pressed.

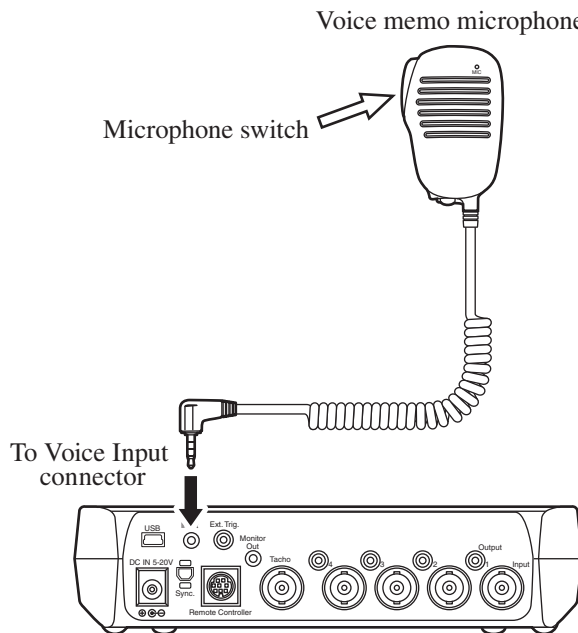
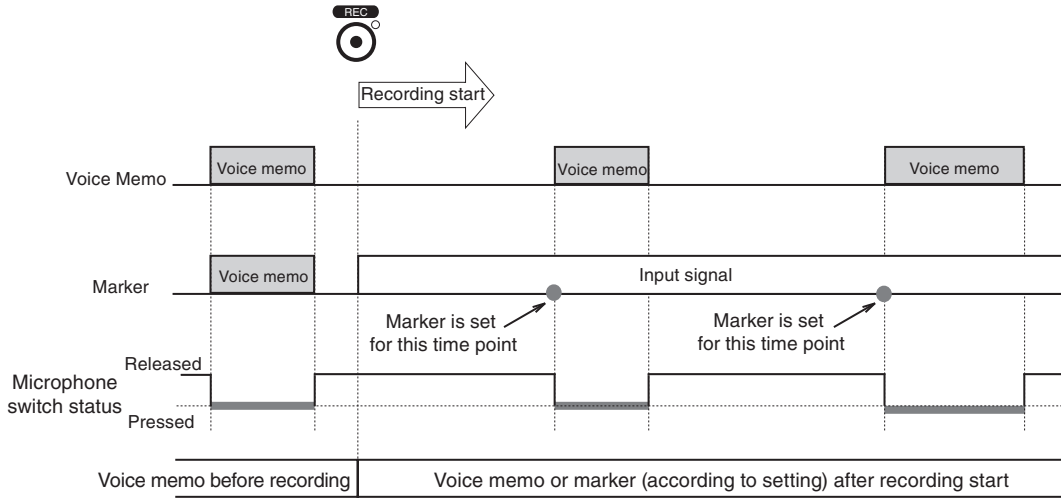

Preventing inadvertent operation (key lock and menu lock)

This section explains the key lock and menu lock functions that serve to prevent operation errors when performing data recording in the field.

Key lock **Makes almost all keys inactive**

Pressing and holding the [←] and [→] keys together for a few seconds activates the key lock condition. In this condition, all keys except the [LIGHT] key and the [←]/[→] keys are locked. Remote control operation remains possible. To cancel the key lock state, press and hold the [←] and [→] keys once more. During key lock, a key lock icon [🔒] appears in the bottom left of the display.

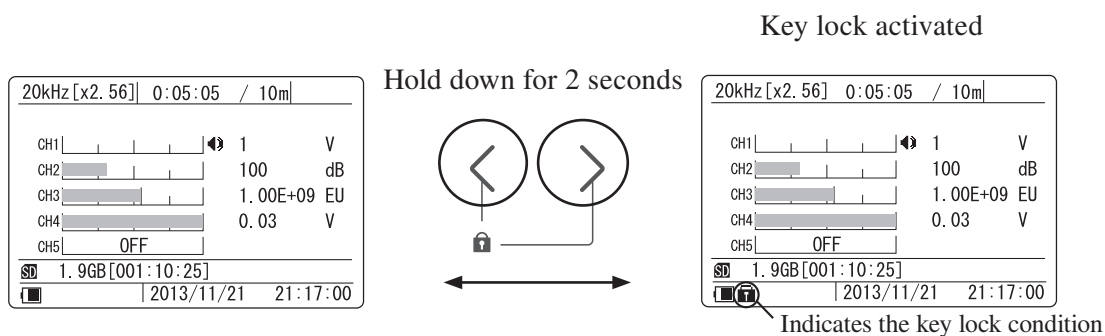

Menu lock **Changing menu settings and deleting data are disabled**

Opening the battery compartment cover gives access to a slide [MENU] switch in the lower left section, as shown in the illustration below. When you set this switch to the LOCK position, menu settings cannot be changed, and data in recall mode cannot be deleted. Only the input range setting can still be changed. This condition is called the menu lock mode.

When menu lock is active, the indication **MENU LOCKED** appears if you call up a menu and attempt to make a setting, or if you attempt to delete data in recall mode.

During menu lock, a menu lock icon  appears in the bottom left of the display.

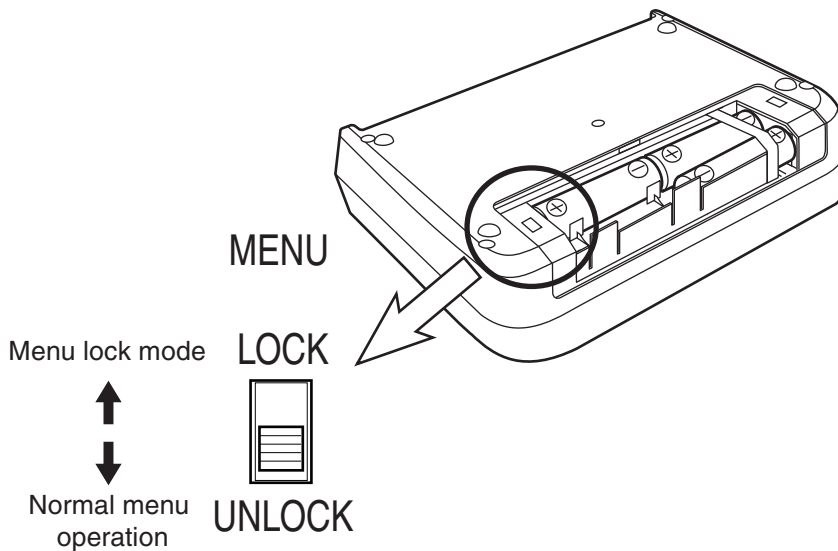

Note

Operate the [MENU] switch only while power to the unit is switched off.

Remote control operation

The optional Remote Controller (DA-20RC1) allows recording start/stop control from a remote location. The controller features simple construction with only a start/stop switch and an operation status indicator. The cable is to be connected to the Remote Controller connector on the DA-21.

The Remote Controller allows for example centralized control of a measurement system including other devices, with the DA-21 used to record data under a given set of conditions. Because the Remote Controller is designed to be operative also when the key lock feature is enabled, the DA-21 can be protected from inadvertent operation.

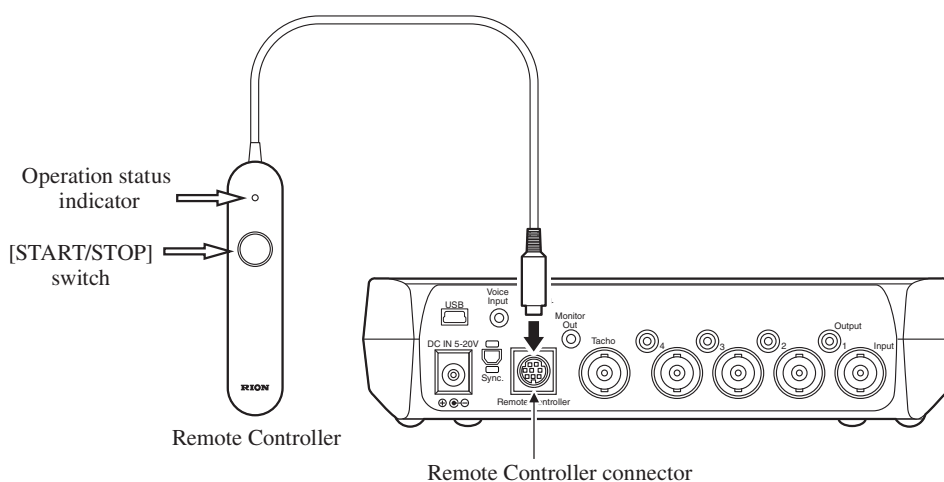

The first push of the [START/STOP] switch on the Remote Controller starts recording. When the switch is pushed while recording is in progress, recording stops. The operation status indicator provides the information listed in the following table.

Status indicator	Operation
Flashing red	Recording
Flashing green	Trigger standby
Lit in red (1 second or more)	Overload has occurred
Off	Other condition

When an overload condition continues, no distinction is made with regard to whether it is before or after recording start. However, recording under permanent overload conditions is a problem. Adjust the input range setting to prevent overload.

Connection to a computer

An SD memory card inserted in the unit will be recognized as a removable disk by the computer when connected via USB, without having to install a USB driver.

Connecting steps

1. Connect the USB connector of the DA-21 with a USB connector of a computer, using the optional (generic) A - mini B USB cable as shown below.

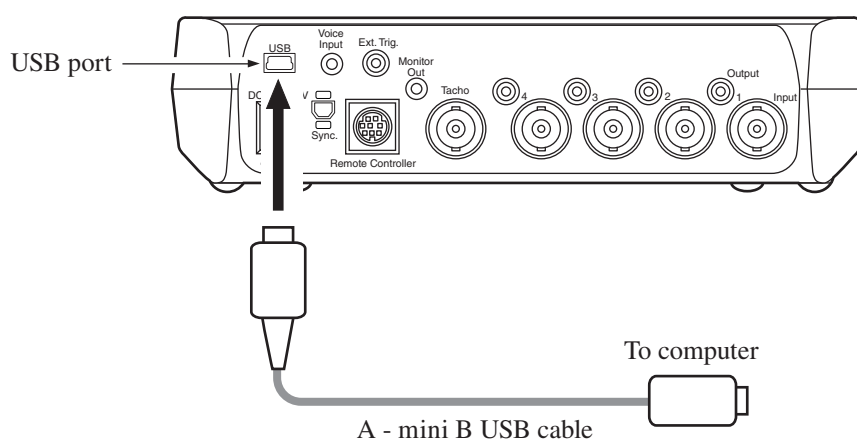

2. Open the <System> menu from the Menu List to select “USB Storage” to ON.

MENU System	
Backlight Settings	
Brightness	2
Auto Off	Continue
Battery Type	Alkaline
Card Format	
USB Storage	ON
Back ↻ [MENU]	Exit ↻ [STOP]
SD 1.9GB [001:10:25]	
■	2013/11/21 21:17:00

Important

Data recording and data recall operation cannot be performed when the state of “USB Storage” is set to ON.

Inter-unit synchronization

Using two DA-21 units and the separately available dedicated cable, synchronized operation with one unit functioning as master and one unit as slave is possible.

Important

Establish the same settings on both DA-21 units (<Rec.Parameters> menu items). If settings are different, synchronized operation is not possible. Also, when the settings are changed after the synchronization, it is necessary to synchronize again.

Check the synchronization information on the display (page 18) after operation of the synchronization.

Note

The size of data files recorded simultaneously on two synchronized DA-21 units will be different for the master unit and the slave unit.

Synchronization procedure

1. Use the optional inter-unit sync cable CC-43 to link the Unit to Unit connectors of the two DA-21 units that are to be synchronized.

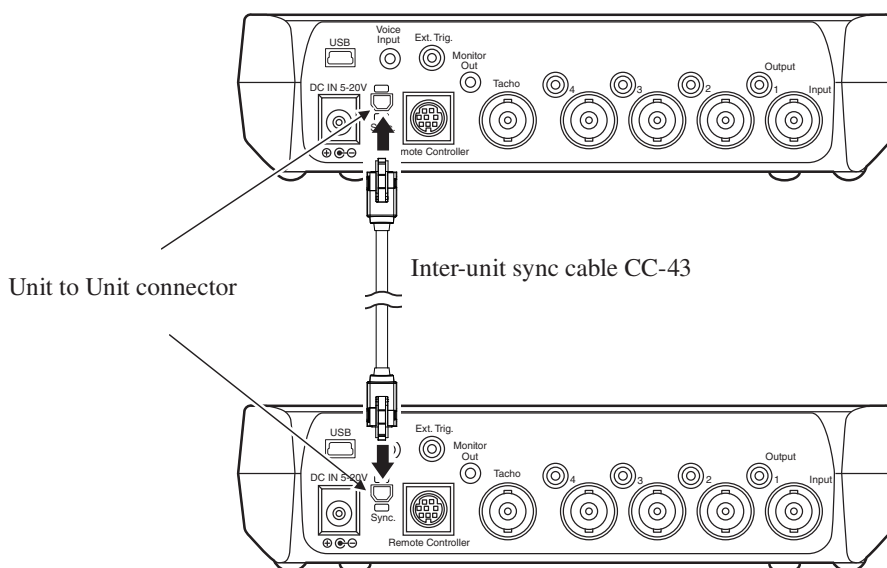

2. Access the menu list and open the <Synchronization> menu.

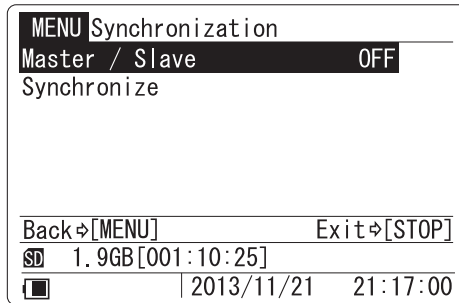

3. In the “Master / Slave” sub menu, select “Master” on the DA-21 to use as master unit and “Slave” on the DA-21 to use as slave unit.

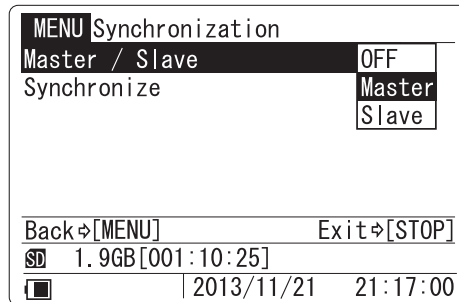

4. Enable synchronized operation by selecting “Synchronize” in the <Synchronization> menu on both units.

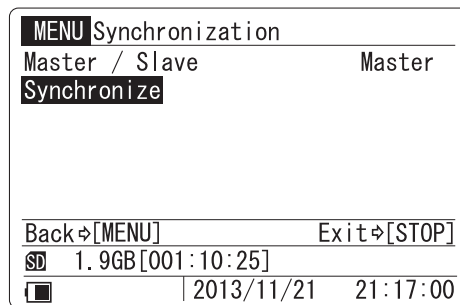

5. The execution choice screen appears. Press the [ENT] key on both units simultaneously.

Recording

First, press the [REC] key of the slave unit to set the slave unit into the trigger standby condition. Then press the [REC] key of the master unit to start the recording.

Tachometer signal input

The rotary pulse input connector serves for input of a rotary pulse signal (Tacho signal). The DA-21 can record the revolution speed derived from a rotating object such as a fan or motor.

When the “Inp” item for CH5 in the <Input> menu is set to “Tacho”, the indication **TC** appears, and the revolution speed is displayed.

Connection example

Connecting a rotary pulse generator

The BNC - BNC coaxial cable EC-90 series (option) can be used to connect a rotary pulse generator equipped with a BNC output, as shown below.

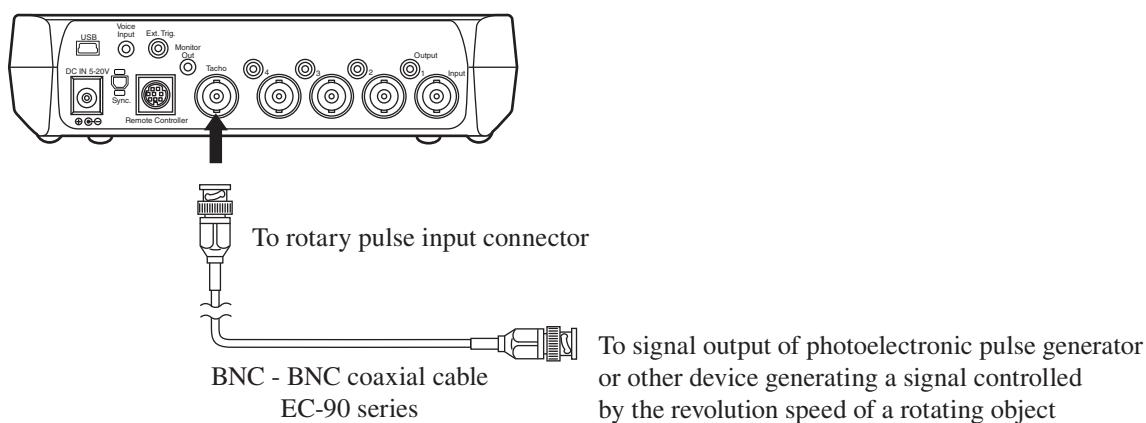

Recording

This section explains the recording process, including pre-recording checks and general steps for recording.

Recording steps

1. Checks before recording

Check the power supply, sensor readiness, and all settings.

2. Adjust input range. Record calibration signal as required.

Adjust the input range setting so that no overload occurs. To ensure that the recorded data correspond to correct measurement values, record a calibration signal before recording. When there has been no change in sensors and recording parameters, this step may be omitted from the second time onwards. If the sensitivity setting of the DA-21 can be considered to provide sufficient accuracy, recording a calibration signal is not necessary.

3. Recording

Use the [REC] key to perform the recording procedure, and repeat as necessary. If any of the items that are to be checked before recording has changed (connection of external equipment, input settings, etc.), return to step 1.

After data recording has started, use the voice memo/marker function and trigger processing as necessary.

1. Checks before recording

Before starting to record, check that all sensors are connected correctly and that all settings are made properly. Items to be checked are listed below.

1. Power supply

- Are inserted batteries in good condition? Are spare batteries available? (See pages 23, 57.) Is an AC adapter or other suitable external power source available?
- Are wake-up-on-power mode settings appropriate? (See page 60.)

2. Auxiliary functions

- Are voice memo and marker settings appropriate? (See pages 40, 85.)
- Has key operation been restricted as required by the usage environment? (Key lock, menu lock mode) (See page 87, 88.)
- Has Remote Controller been connected (as required)? Normally, key lock should be enabled when using Remote Controller.
- Is device index number setting appropriate? (See page 84.)

3. SD memory card

- Is SD memory card certified for use in DA-21? (Insert card and check for messages.) (See pages 12, 61, 121)
- Is enough remaining capacity available? Is spare SD memory card available? (Set number of channels and recording parameters as required, and then check remaining recording time on main screen.) (See pages 9, 22, 129)

4. External equipment connection

- Is sensor configuration appropriate? Have sensor been connected correctly? (See pages 10, 64)

5. Input settings

- Are input and sensitivity settings matched to sensor? (If calibration signal is to be recorded for sensitivity calibration, the sensitivity setting check can be omitted.) (See pages 65 to 69)
- Are unused input channels set to OFF? (Otherwise noise from unused inputs may be recorded as data, unnecessarily using up SD memory card capacity.)
- Are low-pass filter and high-pass filter settings appropriate? (See page 41)

6. Recording parameters

- Trigger (See pages 77 to 83)
- Frequency range, sampling frequency (See page 73)
- Recording time (See page 74)
- Sensitivity setting (See pages 66 to 69)
- Input range (See pages 70 to 72)

2. Input range setting / Calibration signal recording

Changing the input range setting

1. Press the [RANGE] key to cause the input range display section to be shown in reverse (cursor active).
2. Use the [Δ]/[∇] keys to move the cursor to the channel whose input range setting you want to change.
3. Press the [ENT] key to allow changing the current input range setting.
4. Use the [Δ]/[∇] keys to change the input range.
5. Press the [ENT] key.
6. If you want to change the input range for another channel, repeat steps 2 to 5. Otherwise press the [RANGE] key to complete the range setting procedure.

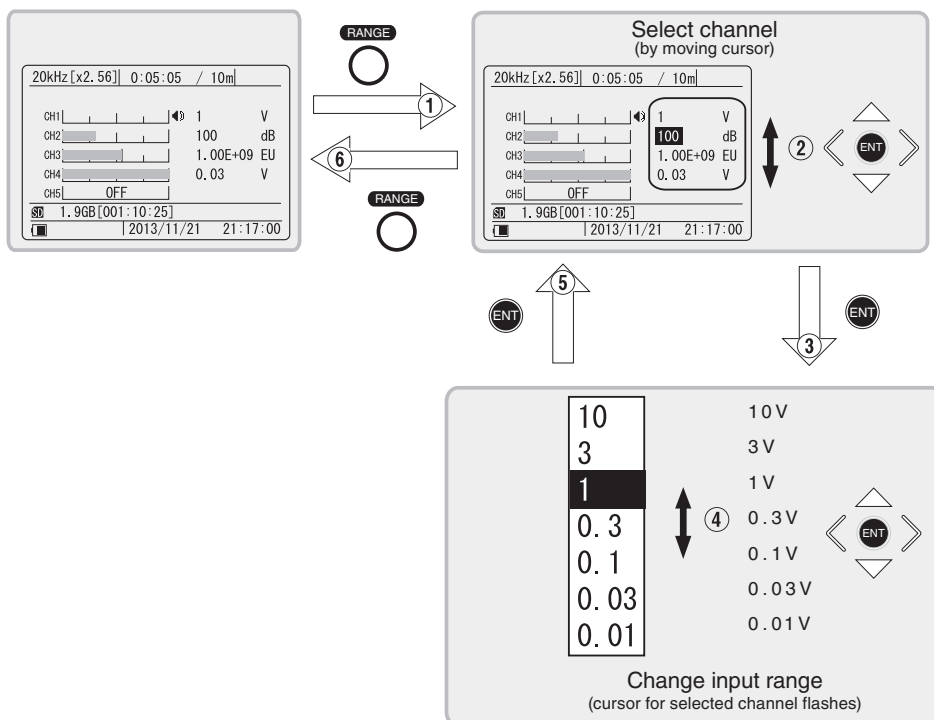

Recording a calibration signal

Calibration for recorded data is normally performed by recording the sensor calibration signal before or after the data recording procedure and by correlating the result to the recorded data.

This method allows correct calibration even if the effect of the configuration elements of the sensor (extension cable, preamplifier, etc.) is unknown.

In principle, it will be necessary to record the calibration signal again when the configuration elements have been changed. Input range information of measuring device will also be required (if range switching is possible).

In the representative examples listed below, recording the calibration signal may be necessary. In actual use, the operator should decide whether calibration is necessary, based on information given in this manual and other data.

1. Input range setting of the measuring instrument (not DA-21) was changed.

The instrument may change output signal being supplied to DA-21 when input range setting is changed even at the same input signal.

2. Extension cable was changed (length, cable gauge, etc.)

A change in electrical impedance may result in a different output signal being supplied to the DA-21.

3. Recording

Starting to record

Press the [REC] key.



The recording procedure begins.

The REC indicator at the top right above the [REC] key flashes, and the REC icon appears on the display.

While recording is in progress, the REC icon flashes, and the elapsed time count based on the recorded data volume is updated. When the elapsed time equals the preset recording time, recording stops.

During trigger standby, the elapsed time count is not updated. If the Pre Recording Time function is used, the elapsed time count does not start from zero but from the Pre Recording Time value.

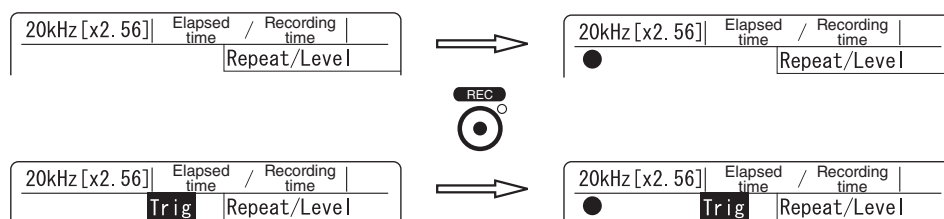

< If one of the following messages appears and recording does not start >

- [NoCard]
 - ⇒ Insert an SD memory card and press the [ENT] key to clear the message. Any [REC] key operation is disregarded.
- [Card Error. Remove card or format card.]
 - ⇒ An SD memory card that cannot be used in the DA-21 was inserted. Press the [ENT] key to clear the message. Any [REC] key operation is disregarded. Format the card by the DA-21 or insert another SD memory card.
- [Disconnect the USB from PC, please off the function “USB Storage” from the system menu.]
 - ⇒ Select “USB Storage” to OFF in the <System> menu.

- [Number of data has reached maximum.]
 - ⇒ The maximum number of data sets that can be created has been reached. Press the [ENT] key to clear the message. Any [REC] key operation are disregarded. Either format the card after copying the data (files) onto a computer, or use a different card which has enough space.

< When does the recording procedure stop? >

The recording procedure stops in the following cases.

1. The amount of data corresponding to the recording time setting has been recorded.
 2. There is no more remaining space on the SD memory card.
 3. The [STOP] key was pressed.
 4. The number of hours in one data file has reached 1000.
 5. The number of WAVE files in a data set (separated into folders by start time) has reached 1000.
 6. The Stop Time set for the time trigger has been reached.
 7. The number of data folders (see 5.) has reached 1000. (In this case, recording cannot be started.)
- * For information on recorded data, refer to page 116.

< “Recording procedure” and “recording in progress” >

The entire process between initiating the recording and the completion of all steps is called the “recording procedure”. This also includes the trigger standby conditions during which no actual data are being recorded. The condition where actual data are being recorded (i.e. where the unit is not in the trigger standby condition) is called “recording in progress”.

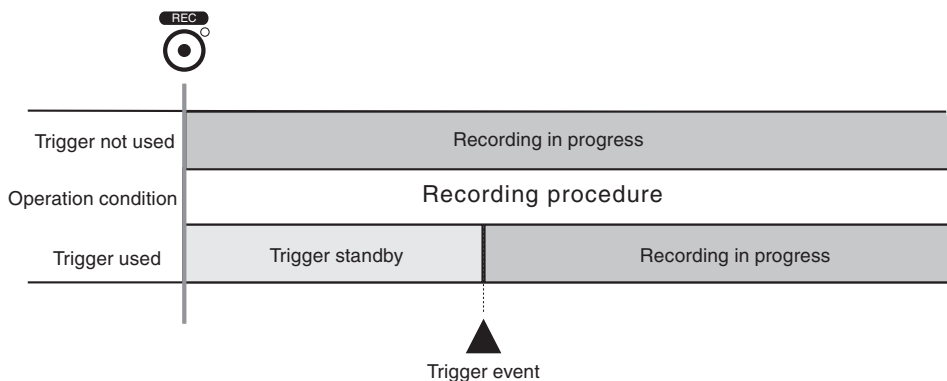

< Overload history and display >

The overload history display **OVER** can be turned off during recording by pressing the [CLEAR Ov] key. However, only the display is turned off. The information about any overload that occurred is recorded along with the data. The capability is used to monitor any further overload occurrences after overload has occurred and been noted. The voice memo or marker function can also be used in addition to overload monitoring, which can be helpful when analyzing data later.

The overload history does not comprise information about any overload that occurred during trigger standby or during voice memo recording.

Terminating a recording partway

Press the [STOP] key.



The REC indicator and the REC icon go out and recording stops.

After a long-term recording or when there is a large number of files on the SD memory card, data recording to the SD memory card may take some time. Do not remove the SD memory card during data recording.

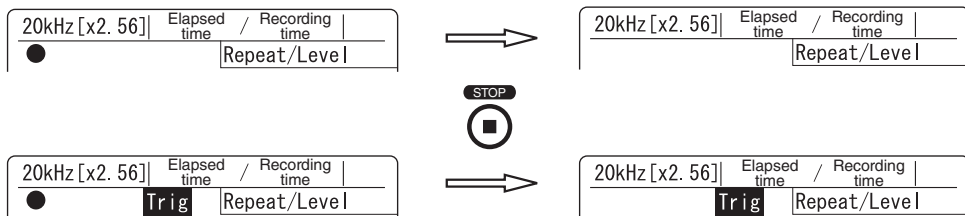

Recording procedure conditions and indicator/icon status

The various conditions of the unit during the recording procedure can be checked using the indicators and the icon status.

The two illustrations below show the various conditions, with and without the use of the trigger function. (Flashing of an indicator or icon is indicated in the illustration as )

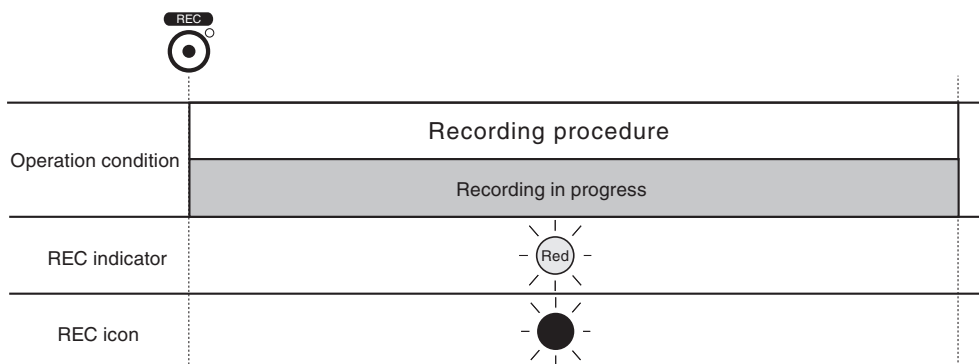

Basic recording

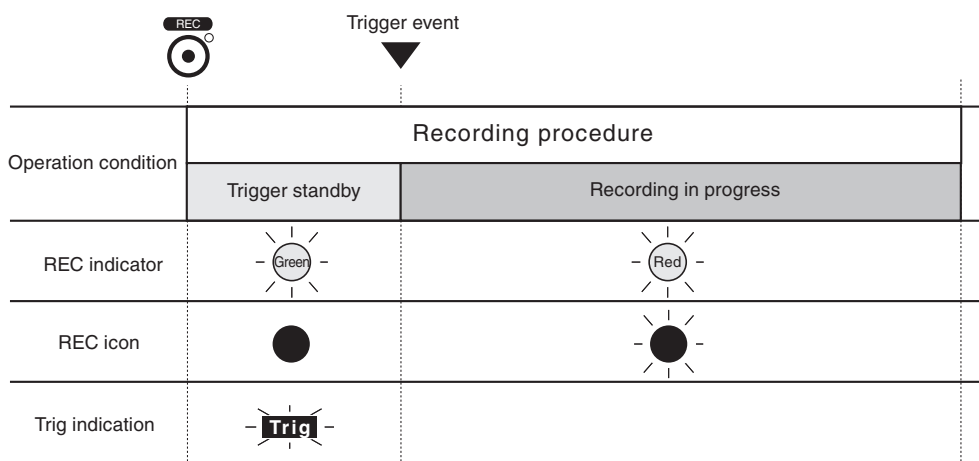

Recording with trigger function

Using the voice memo/marker function

Voice memo

Voice memo recording on the SD memory card starts when the microphone switch is pushed and stops when the switch is released. The audio level is indicated by the bar graph for CH5 during voice memo is activated, and the **VO** icon is shown on the right side of the bar graph.

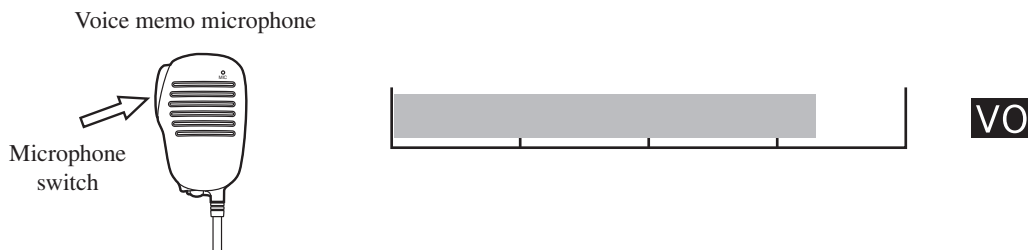

When the unit is currently not performing the recording procedure, voice memo recording is possible at any time. When voice memo recording was stopped but the voice memo file is still being written to the SD memory card, the [REC] key is not accessible.

When the unit is currently performing recording, voice memo recording can be started only while recording is in progress (not during trigger standby).

When the “Inp” item for CH5 is set to except “Voice Memo”, voice memo recording while recording is in progress is not possible.

When the microphone switch is operated, noise (overload) may occur.

Marker

When the microphone switch is pressed while data are being recorded, the current time is recorded as a marker. The **MK** icon is shown on the right side of the bar graph for CH5 during marker is selected.

Pressing the switch also causes the **MK** icon to flash for about one second.

The marker function can only be used while recording is in progress.

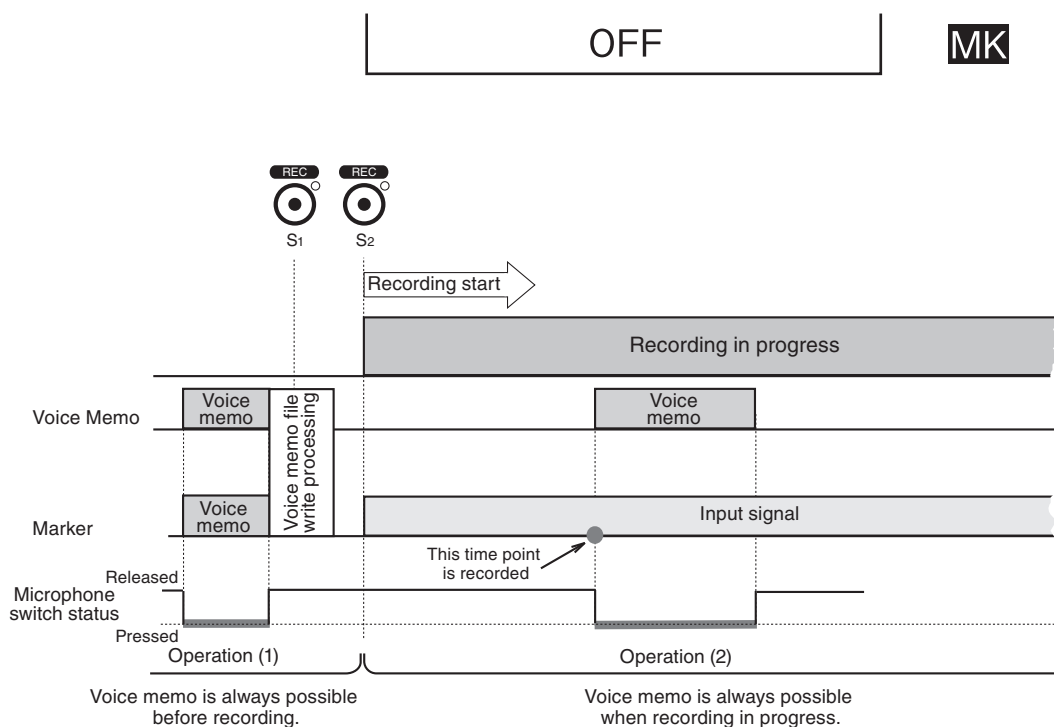

The above illustration shows the voice memo/marker operation in detail when the trigger function is not used. During the operation (1) interval, recording is not in progress and voice memo recording is possible at any time, regardless of voice memo/marker setting. However, while a voice memo file is being written to the SD memory card, [REC] S1 is not accepted, and at [REC] S2, recording is already in progress. The marker information is recorded only when the switch is pressed while recording is in progress, as in operation (2).

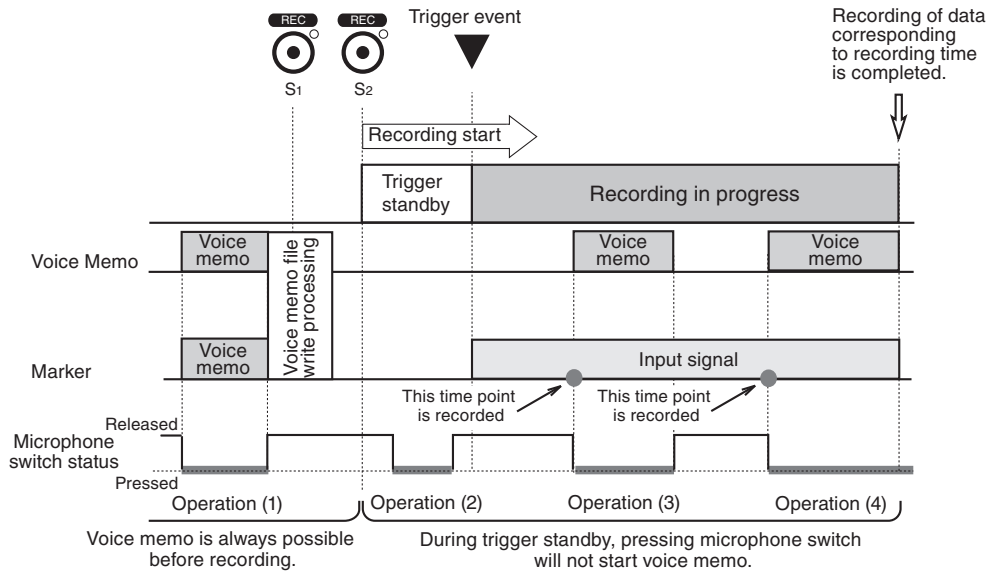

The above illustration shows the voice memo/marker operation in detail when the trigger function is used.

Except for the fact that voice memo operation is disregarded during trigger standby, operation is the same as when the trigger function is not used. During the voice memo operation interval (4), the voice memo recording will be interrupted at the point where data recording is complete, even if the microphone switch is kept depressed. (The same applies for recording end when the trigger function is not used.)

Data recording example

Monitor road noise and record sound pressure waveform when a given level is exceeded

The sound level meter NL-42/NL-52/NL-62 is used to measure noise levels. The comparator signal and AC signal of the sound level meter are used for recording the waveform on the DA-21.

Input the comparator signal of the sound level meter to the Ext. Trig. connector of the DA-21, using the comparator output cable CC-42C. For voice memo recording, connect the optional voice memo microphone to the Voice Input connector. Input the AC signal of the sound level meter to the channel 1 (CH1) connector of the DA-21.

Make the DA-21 settings as follows.

Input settings (using <Input> menu)

CH	Inp	HPF	LPF	Sens	Sensitivity
1	AC	OFF	OFF	SLM	Level range value: dB
2	OFF	OFF	OFF		
3	OFF	OFF	OFF		
4	OFF	OFF	OFF		
5	Voice Memo	OFF	OFF		

(CH1 is to be used for waveform recording. CH5 is to be used for voice memo recording.)

Auxiliary functions

- Set device index number to level range value of sound level meter (for calibration signal recording: see page 84)
- Set comparator level of sound level meter to level of signal to record.
- Set key lock to ON.

Recording parameters

Recording parameters		Recording parameters	
Item	Setting	Item	Setting
Trigger mode	Repeat	Trigger type	External
Recording time	15 s	Pre Recording Time	5 s
Frequency range	20 kHz	Sampling frequency	×2.56
Input range	Suitable value		

Procedure

1. Record calibration signal of sound level meter (at this time, trigger mode should be set to “Free”).
2. Cancel calibration mode at sound level meter. Set trigger mode back to “Repeat” and recording time to “15 s”.
3. Press the [REC] key to enable trigger standby.
4. Record voice memo as necessary.
5. Press the [STOP] key to terminate recording.

Note

It is also possible to select “SLM” for the “Sens” item and set the sensitivity to the level range (full-scale value) of the sound level meter, without recording the calibration signal. However, for optimum measurement accuracy, recording the calibration signal of the sound level meter is preferable.

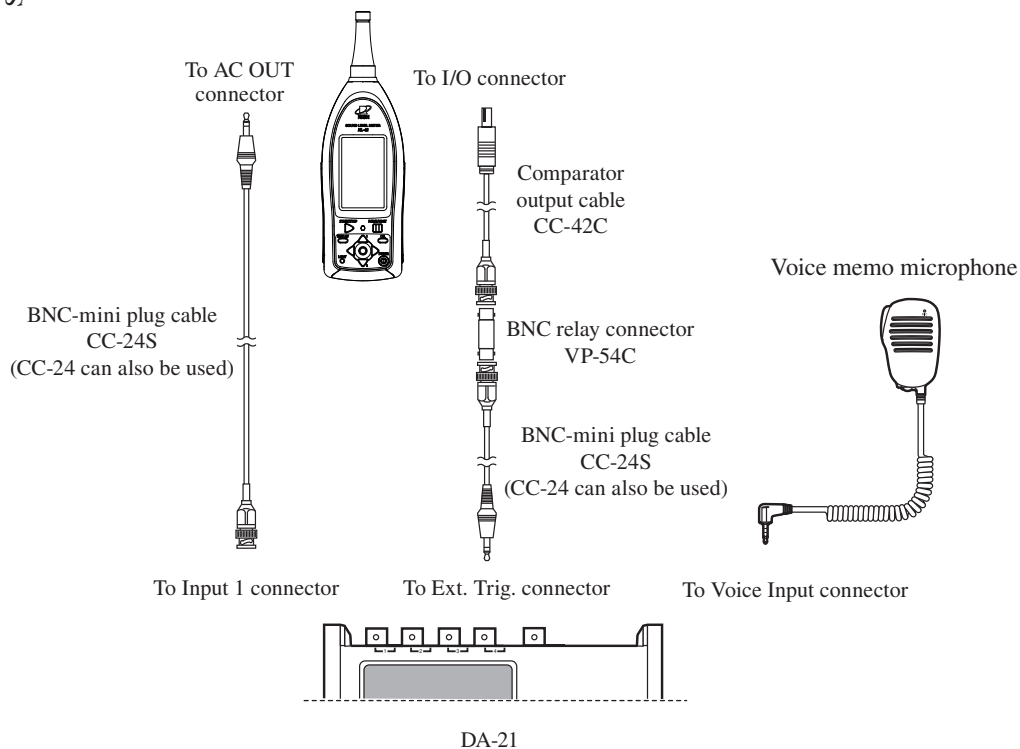
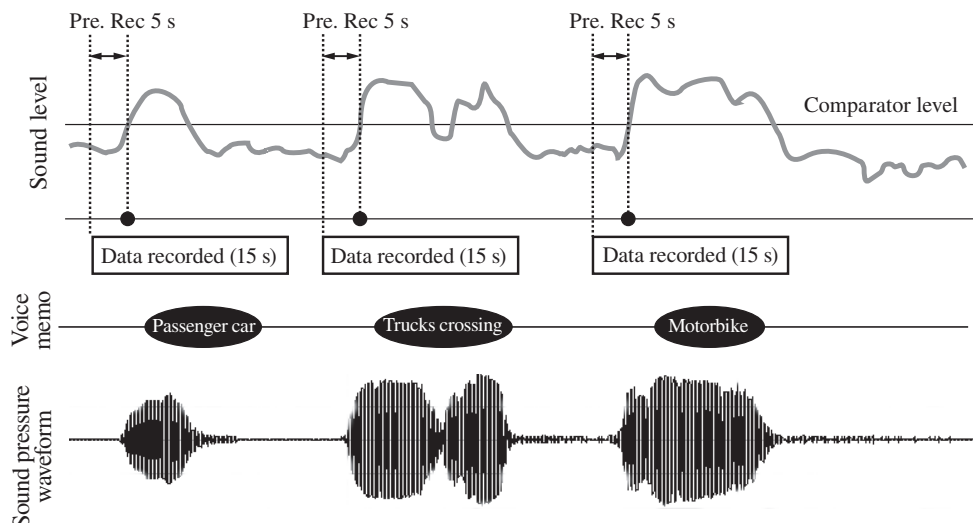

Generated file name	File name corresponding to the recording start time (Trigger 1)	File name corresponding to the recording start time (Trigger 2)	File name corresponding to the recording start time (Trigger 3)
Recorded sound pressure waveform (channel 1)			
Voice memo (channel 5)	Passenger car	Trucks crossing	Motorbike

Recall/Playback of Recorded Data

You can call up a list of recorded data and select data for playback and for checking. You can also delete unwanted data or determine whether data have to be recorded again.

(For a flow chart of the overall operations described in this section, see page 118.)

Activating recall mode

Press the [RECALL] key. The Select File screen appears, and the unit switches to recall mode.

Note

When there are a lot of data on the SD memory card, entering recall mode may take some time.

The Select File screen displays up to 1000 of the most recent recorded data sets.

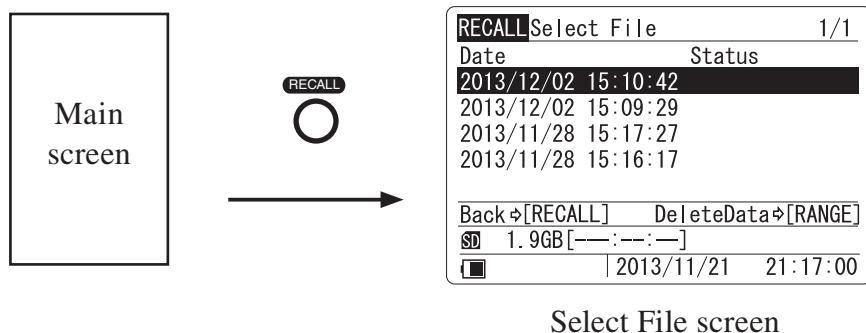

Press [RECALL] key again in the Select File screen to return to the main screen.

When activating the recall mode, the following message may appear.

- If no SD memory card is inserted

The recall mode cannot be activated. In this case, the indication **NoCard** appears on the display for a few seconds, and then the main screen appears again.

Viewing recorded data

The Select File screen shows the recording start time and status of the data. The Status field shows “Voice Memo” if this was recorded during a recording procedure. The Status field also shows “TACHO” if this was the tachometer signal.

For data recorded with the repeat trigger function, the number of the trigger event is shown on the Status field. (For example, Trigger-1 indicates data recorded at the first trigger event.) Use the [Δ]/[∇] keys to move the cursor.

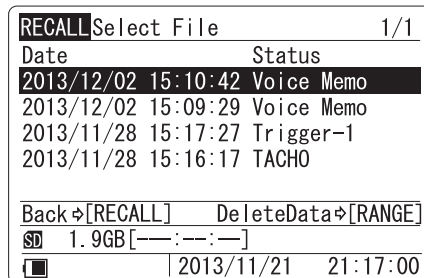

Select File screen

Deleting recorded data

The Select File screen also lets you delete the recorded data.

1. Move the cursor to the recorded data to delete and press the [RANGE] key.
2. The execution choice screen appears. Press the [ENT] key or [PAUSE] key.

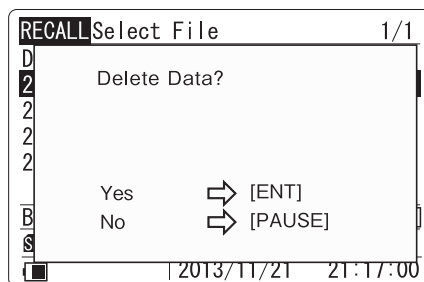

Selecting recorded data for playback

Move the cursor to the recorded data you want to play back, and press the [ENT] key. The recall screen appears, and the recorded data can be played back.

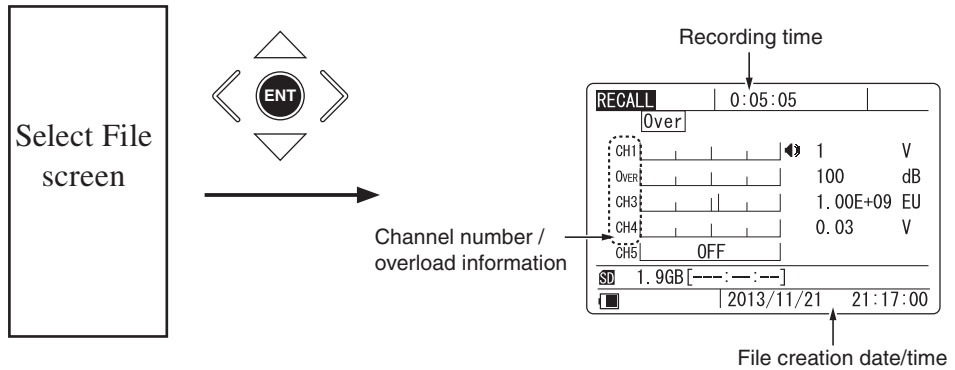

The recall screen provides information about recording time, input range, overload history, etc. The recording time is the time corresponding to the actual recorded data. For data where recording was stopped partway, this will be shorter than the recording time specified via the menu.

Playback of recorded data can also be started from this screen. The [←]/[→] keys can be used to select recorded data.

Playback of recorded data

The recall screen gives access to various operations related to playback of recorded data.

Playing recorded data

Press the [PLAY] key.



Playback of recorded data starts.

During playback, the PLAY indicator at the top right of the [PLAY] key flashes, and the playback icon ► flashes on the display. When all recorded data have been played, playback stops. During playback, the bar graphs are linked to the playback signal. The recording time indication changes to elapsed playback time indication.

The playback signal of the monitor channel is output at the Monitor Out connector. The playback signal of each channel is also output at the Output connectors. The recorded data can be checked by supplying these signals to earphones, monitoring devices, or similar.

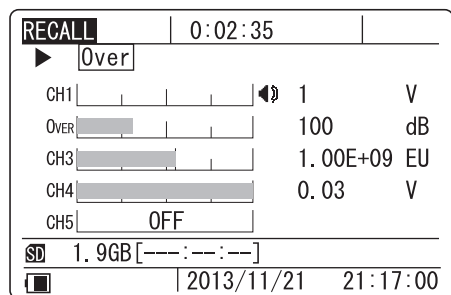

Playback screen example

Stopping playback partway

Press the [STOP] key.



The PLAY indicator and playback icon ► go out, and the unit returns to the recall screen.

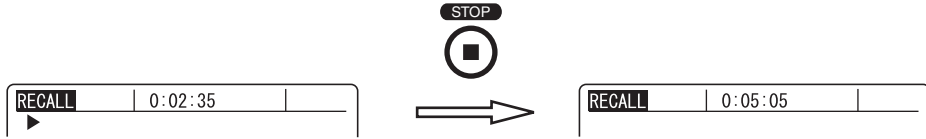

Pausing and restarting playback

Press the [PAUSE] key.



Playback is halted temporarily. In this condition, the pause icon || flashes on the display.

When you press the [PAUSE] key once more, the pause icon || goes out and playback resumes.

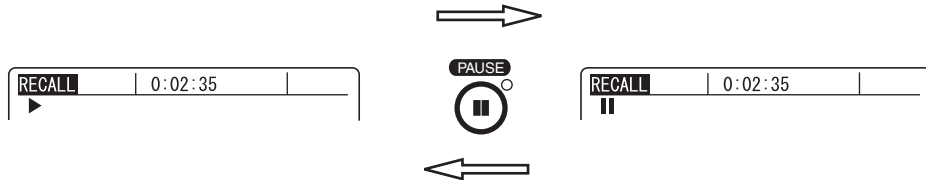

Performing fast forward or reverse during playback

Press and hold the [>]/[<] keys.

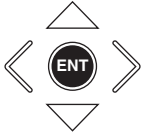

While you press the [>] or [<] key, the playback position is moved quickly forwards or backwards. During this time, no playback signal is output. If the playback position was moved all the way to the end of the recorded data, playback will stop when you release the [>] key. If the playback position was moved all the way to the beginning of the recorded data, playback will start when you release the [<] key.

The speed of fast forward or reverse is about 4 times higher than regular playback.

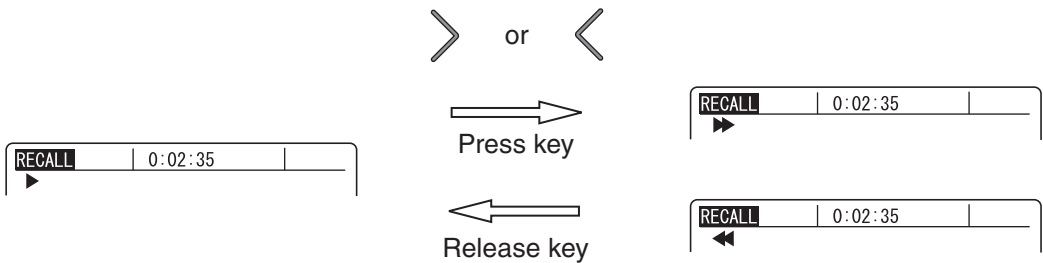

Fast forward or reverse occurs while [>] or [<] key is pressed

Performing high-speed forward or reverse during playback

While playback is paused, press and hold the [>] or [<] key.

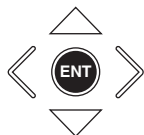

When you hold down the [>] or [<] key for about one second, high-speed forward or reverse starts and the playback position is moved quickly forwards or backwards. When you release the key, the unit returns to the playback pause condition at that point. The speed of high-speed forward or reverse is about 60 times higher than regular playback. If you press the [>] or [<] key and release it within less than one second, the unit jumps to the voice memo start position or marker position.

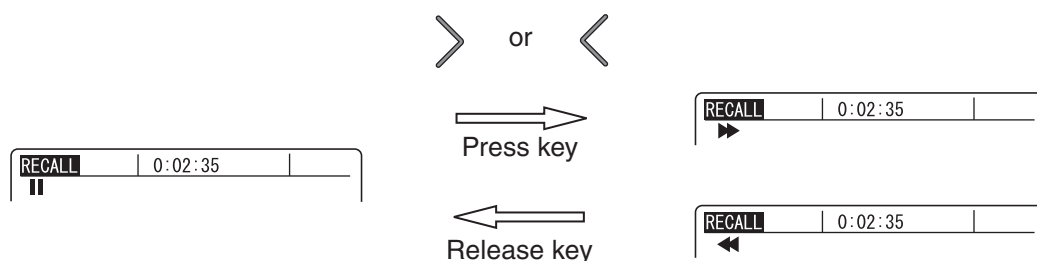

High-speed forward or reverse occurs while [>] or [<] key is pressed

Jumping to the voice memo start position or marker position

While playback is paused, press the [>] or [<] key.

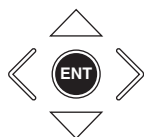

When you press the [>] or [<] key, the playback position jumps forwards or backwards to the next (closest) voice memo start position or marker position. If there is no voice memo start position or marker position in that direction, the position jumps to the end or the beginning of the recorded data. The elapsed playback time indication changes when the position changes, letting you check the movement.

Canceling recall mode

When you press the [RECALL] key at the Select File screen, the recall mode is terminated and the unit returns to the main screen.

If a recall screen is currently shown, press the [RECALL] key once to return to the Select File screen, and then press it again to cancel the recall mode.

When the unit returns to the main screen, a constant current may be output from a channel for which CCLD is selected. The power supply condition is checked, and the unit may be shut down if battery capacity is insufficient.

In such a case, replace the batteries with a fresh set, or use an AC adapter or other suitable external power source.

Other information

When SD memory card was removed in recall mode

While the unit is in recall mode, you should not remove the SD memory card. If the SD memory card is removed, the recall mode will be canceled and the unit returns to the main screen.

Important
If you remove the SD memory card while the card is being accessed, damage may occur.

About the supplied viewer software

Using the supplied viewer software, WAVE files can be imported from the SD card and waveforms can be displayed on the computer.

The file structure on the SD memory card is as follows.

DA21.INI	Setting file
└ Record	
└ YYYY-MM-DD_HHMMSS	The folder is identified by start time (Recorded data)
└ WR_xxx_YYYYMMDD_HHMMSS_yyyy.wav	Wave recording file is WR
└ MM_xxx_YYYYMMDD_HHMMSS.wav	Voice memo file is MM
└ YYYY-MM-DD_HHMMSS	
└ WR_xxx_YYYYMMDD_HHMMSS_yyyy.wav	
└ TC_xxx_YYYYMMDD_HHMMSS.wav	Rotary measurement file is TC
└ Other	
└ MM_xxx_YYYYMMDD_HHMMSS.wav	Voice memo file when the recording is not performed

YYYY-MM-DD: Year(YYYY)-Month(MM)-Day(DD)
 YYYYMMDD: Year(YYYY)Month(MM)Day(DD)
 HHMMSS: Hour(HH)Minute(MM)Second(SS)
 xxx: Index number
 yyyy: Split file number

To observe the waveform of recorded data with the viewer software, select the “.wav” file in the folder. The folder name “YYYY-MM-DD_HHMMSS” corresponds to the indication shown on the Select File screen in recall mode.

Important

Do not change the .wav file name. The file data is not played back correctly.

The DA21.INI file contains information about all settings of the DA-21 (see page 52). You can also store the file with a suitable file name on the computer, and use different files to manage various settings.

Important

Use only RION supplied SD memory cards. Operation with other cards is not assured.

Note

Only WAVE files that were recorded with the DA-21 can be played using the DA-21.

Recall Mode Operation Flow Chart

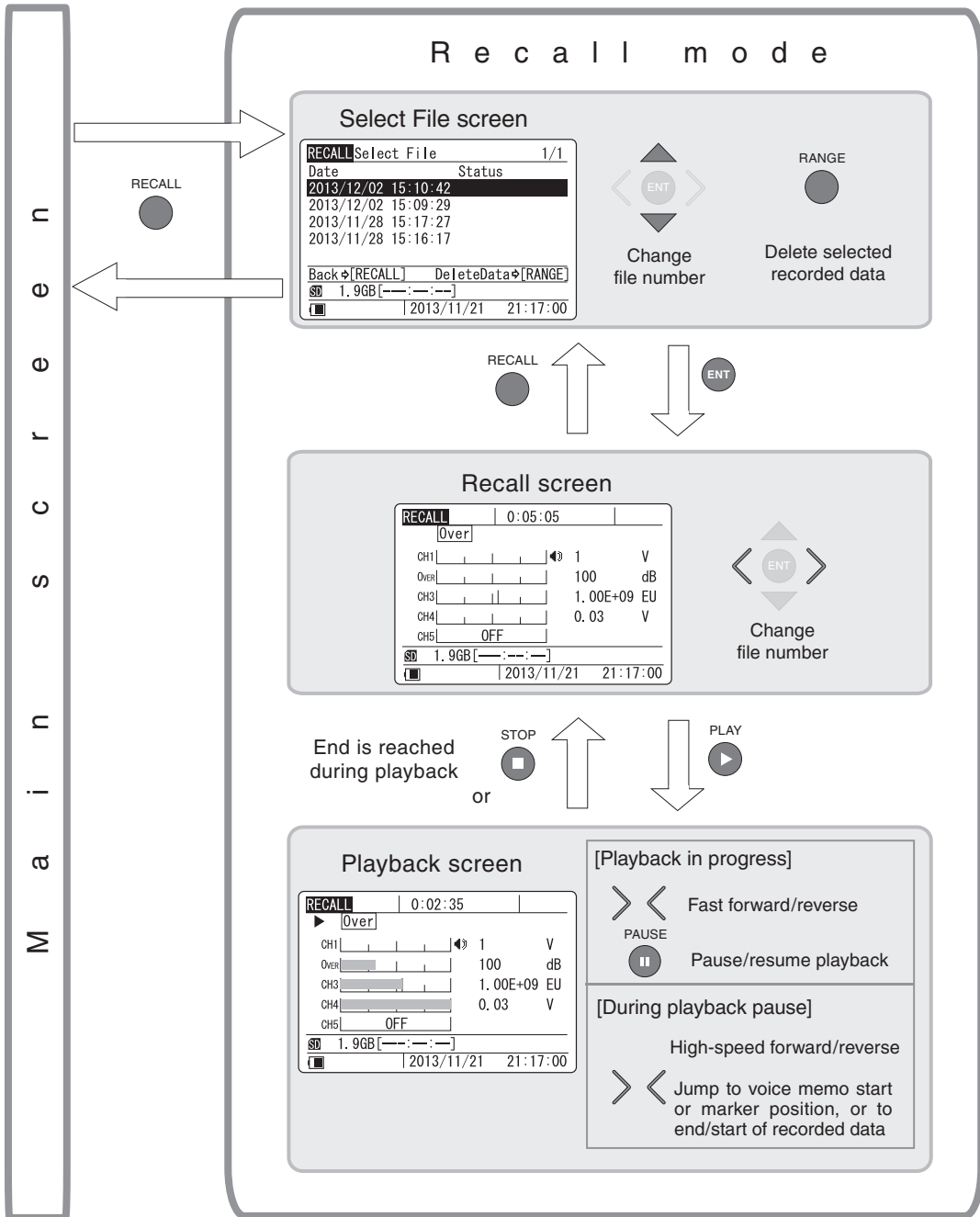

Messages

During operation of this unit, various messages giving warnings and providing procedure information will appear. The most important messages are listed and described in this section.

(The actual font and placement of the message on the display may differ from the examples shown here.)

Messages are listed below. A representative display state where the message may appear is given in parentheses. The message explanations in this section are also in the same order.

Adjustment failed.----- (Power-on)
Card Error.----- (Power-on etc.)
Cannot Record. All ...----- (Menu setting)
Cannot Record. Card ...----- (Voice memo, recording)
Number of data ... ----- (Voice memo, recording)
MENU LOCKED----- (Menu display, data deletion)
NoCard ----- (Recording start, Recall mode)
Disconnect the USB ...----- (Recording start, Recall mode)
Now Closing file.----- (Voice memo, recording)
Save Settings.----- (Menu setting)
Default settings. ----- (Power-on)
Please check having ... ----- (Inter-unit synchronization)
Synchronization will be ... ----- (Inter-unit synchronization)
Please perform the ... ----- (Inter-unit synchronization)

The message explanation uses the following pattern.



Description	Explains the meaning of the message or the condition it refers to.
Countermeasure	Describes steps to take when the message is shown.
Condition	Describes the operation steps or unit condition that can lead to the message being shown. (Omitted where not necessary.)

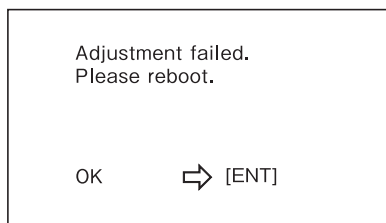

- | | |
|----------------|---|
| Description | At power-on, the unit performs various adjustment routines. If these cannot be completed within a certain period, this message appears. |
| Countermeasure | Press the [ENT] key to clear the message, and then perform a power-down, power-on cycle. |
| Condition | ● Indication “Adjustment Executing” was displayed for about 1 minute during the power-on phase. |

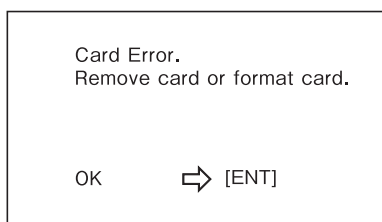

Description	<p>The inserted SD memory card cannot be read/written in the DA-21.</p> <ul style="list-style-type: none">● Folder/file structure as required by the DA-21 is not present, or another folder/file structure exists.● There has been an error while managing a file required by the DA-21.● The card was formatted using a file system other than FAT16 or FAT32, or the card is defective.
Countermeasure	<p>Press the [ENT] key to clear the message.</p> <p>Format the card in the DA-21. If the message is still shown, try a different SD memory card.</p> <p>Formatting a card will permanently delete all data present on the card. Copy any data that are still required to another location on the computer before starting the formatting process.</p>
Condition	<ul style="list-style-type: none">● At power-on, or when an SD memory card is inserted/removed.● Recording procedure or recall mode was activated.● Attempted to write unit settings via a menu item.

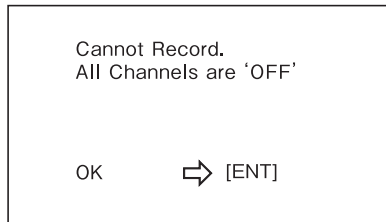

- Description** All channels are set to OFF.
- Countermeasure** Press the [ENT] key to clear the message. The unit is functioning normally, but data cannot be recorded. To record data, set at least one channel to a setting other than OFF.
- Condition** ● Quitting a menu screen and returning the main screen.
- Trying to activate recording by pressing [REC].
-

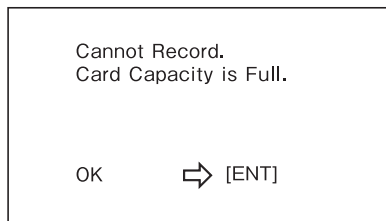

- Description** There is not enough space on the SD memory card to write data.
- Countermeasure** Press the [ENT] key to clear the message. (Data recorded up to that point will be saved on the SD memory card.) Copy the existing files on the SD memory card to a suitable location on the computer, and then format the SD memory card. Alternatively, provide another SD memory card.
- Condition** ● Card became full during recording.
- Attempted to start recording while no space was available on card.

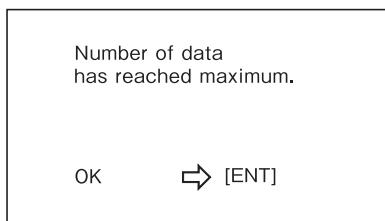

Description	The maximum number of data that can be recorded with the DA-21 has been reached.
Countermeasure	Press the [ENT] key to clear the message. Copy the existing files on the SD memory card to a suitable location on the computer, and then format the SD memory card. Alternatively, provide another SD memory card.
Condition	<ul style="list-style-type: none"> ● Attempted to start recording procedure. ● Attempted to record voice memo from main screen.

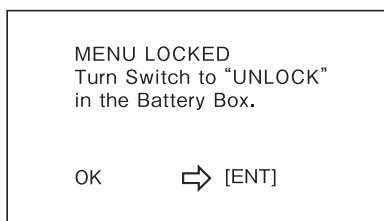

Description	<p>One of the following actions was attempted in menu lock mode.</p> <ul style="list-style-type: none"> ● Tried to change a setting in a menu ● Tried to delete data (recall mode)
Countermeasure	<p>Press the [ENT] key to clear the message.</p> <p>If you want to proceed with the menu setting or data deletion, cancel the menu lock mode (see page 88).</p>

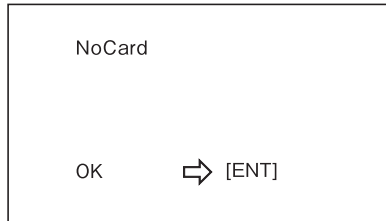

- Description** No SD memory card is inserted in the DA-21.
- Countermeasure** Press the [ENT] key to clear the message.
Insert an SD memory card.
- Condition**
- Attempted to start recording procedure.
 - Tried to enter recall mode.

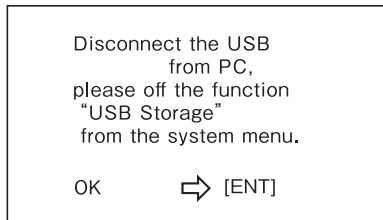

- Description** “USB Storage” in the <System> menu is selected ON.
- Countermeasure** Press the [ENT] key to clear the message.
Set “USB Storage” to OFF in the <System> menu.
- Condition**
- Attempted to start recording procedure.
 - Tried to enter recall mode.

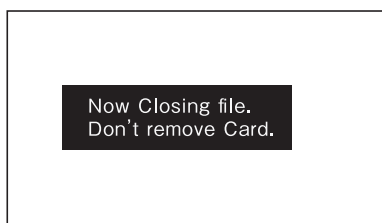

Description	Data recording was completed, and information necessary for data management is currently being written to the SD memory card.
Countermeasure	<p>Never remove the SD memory card in this condition. Be sure to wait until the message has disappeared. Otherwise the card may become unusable until formatted in the DA-21 (at this time, previously recorded data will also be destroyed).</p> <p>While the message is being shown, the [REC] key is inactive and any trigger event is disregarded.</p>
Condition	<ul style="list-style-type: none"> ● Data recording is completed. ● Voice memo recording from main screen was stopped.

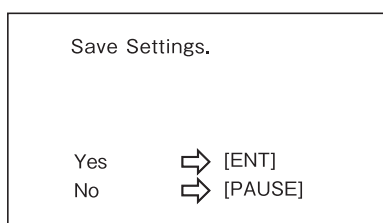

Description	Select whether to save the current settings of the unit.
Countermeasure	<p>Press the [ENT] key to save, [PAUSE] key to cancel. When you press the [ENT] key, the settings of the DA-21 are saved as a setting file on the SD memory card. (The file name is fixed to DA21.INI.)</p>
Condition	<ul style="list-style-type: none"> ● When executing “Save Settings” item of <System> menu.

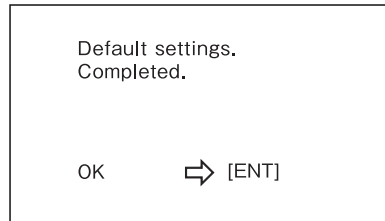

- Description** This message appears at power-on if the input range and menu settings from the last use could not be saved properly. All settings will return to the factory default condition.
- Countermeasure** Press the [ENT] key to clear the message.
Make the required settings again before starting to record.
-

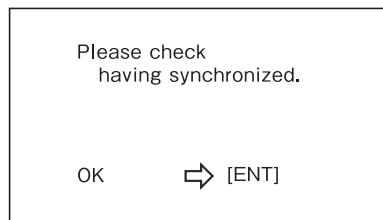

- Description** This message asks for check after operation of inter-unit synchronization.
- Countermeasure** Press the [ENT] key to clear the message.
Check the synchronization information on the display (page 18).
- Condition** ● When executing inter-unit synchronization (page 91).

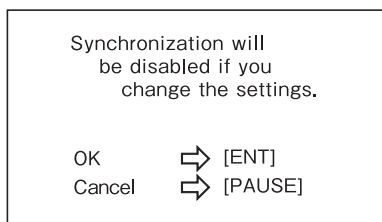

Description	This message warns that change of the settings of synchronized DA-21 will cancel the synchronization.
Countermeasure	Press the [ENT] key when you would like to continue operation. Press the [PAUSE] key when you would like to interrupt operation.
Condition	● When pressing the [MENU] key of synchronized DA-21.

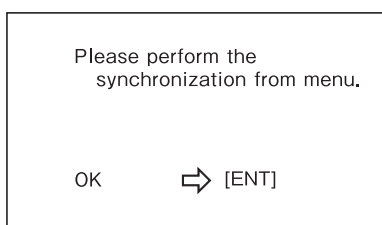

Description	This message asks for re-synchronization of the DA-21 units because the synchronization of DA-21 units was canceled.
Countermeasure	Press the [ENT] key to clear the message. Repeat the synchronization procedure (page 91) when you would like to synchronize two DA-21 units again.
Condition	● When the synchronization of DA-21 units was canceled.

Filter Characteristics

The characteristics of the built-in low-pass and high-pass filters are shown below.

The available low-pass filter settings are OFF, 200 Hz, 1 kHz, and 2 kHz, but the setting must be equal to the frequency range setting or lower. When the OFF setting is selected, the low-pass filter is set to the cutoff frequency of the frequency range.

The available high-pass filter settings are OFF and 5 Hz. For DC channels, the available setting is OFF. For AC and CCLD channels, a 0.3 Hz high-pass filter will apply even if the OFF setting is selected.

High-pass filter characteristics

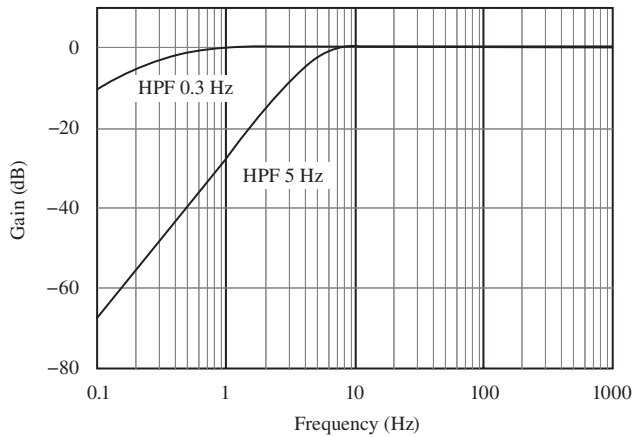

Low-pass filter characteristics

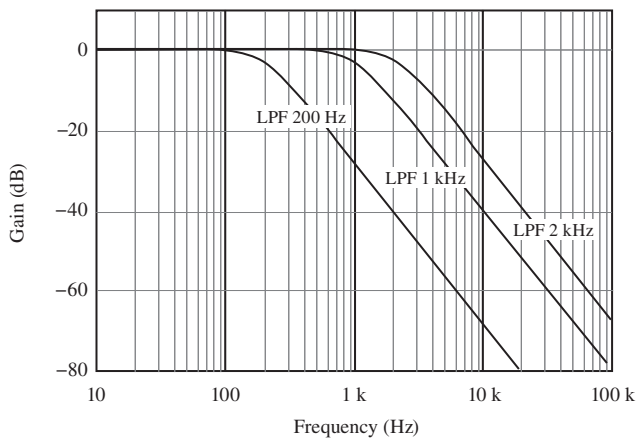

Settings and Other Information

This section lists all menu settings, data recording operation types, and other relevant information.

Approximate recording times

The approximate recording times available with an SD memory card inserted in the unit are as shown in the table below (bit length setting 16 bit). With the 24 bit setting, times are about one third shorter.

The maximum time for a single recording operation is 1000 hours. When this limit is reached, recording is terminated automatically. The maximum number of files that can be recorded in a single operation is 1000 (including voice memo files and revolution speed files). When this number is reached, recording is terminated automatically.

The available recording time differs depending on the type of SD memory card. Please note that these are approximate values provided for reference.

2 GB SD memory card (Sampling frequency: ×2.56)						
Number of channels	Frequency range					
	100 Hz	500 Hz	1 kHz	5 kHz	10 kHz	20 kHz
1	1066 h 40 m	213 h 20 m	106 h 40 m	21 h 20 m	10 h 40 m	5 h 20 m
2	533 h 20 m	106 h 40 m	53 h 20 m	10 h 40 m	5 h 20 m	2 h 40 m
3	355 h 32 m	71 h 6 m	35 h 33 m	7 h 6 m	3 h 33 m	1 h 46 m
4	266 h 40 m	53 h 20 m	26 h 40 m	5 h 20 m	2 h 40 m	1 h 20 m

32 GB SD memory card (Sampling frequency: ×2.56)						
Number of channels	Frequency range					
	100 Hz	500 Hz	1 kHz	5 kHz	10 kHz	20 kHz
1	17066 h 40 m	3413 h 20 m	1706 h 40 m	341 h 20 m	170 h 40 m	85 h 20 m
2	8533 h 20 m	1706 h 40 m	853 h 20 m	170 h 40 m	85 h 20 m	42 h 40 m
3	5688 h 32 m	1137 h 36 m	568 h 48 m	113 h 36 m	56 h 48 m	28 h 24 m
4	4266 h 40 m	853 h 20 m	426 h 40 m	85 h 20 m	42 h 40 m	21 h 20 m

Menu items

<Input> menu (page 39)

Item	Description	Settings
Inp (CH1 to CH4)	Sensor signal type	[OFF] / [DC] / [AC] / [CCLD] / [VP4x]
Inp (CH5)	CH5 input signal type	[OFF] / [Tacho] / [Voice Memo] / [Marker]
HPF	High-pass filter frequency	[OFF] / [5 Hz]
LPF	Low-pass filter frequency	[OFF] / [200 Hz] / [1 kHz] / [2 kHz]
Sens	Sensor type	[V] / [EU] / [MIC] / [PICK] / [SLM] / [VM]
Sensitivity	Sensor sensitivity/unit conversion	[V/EU] / [dB] / [mV/(m/s ²)] / [pC/(m/s ²)]

<Rec.Parameters> menu (page 44)

Item	Description	Settings
Frequency Range	Frequency range	[100 Hz] / [500 Hz] / [1 kHz] / [5 kHz] / [10 kHz] / [20 kHz]
Sampling Frequency	Sampling frequency	[×2.4] / [×2.56]
Bit Length	Bit Length	[16 bit] / [24 bit]
Wave Splitting Interval	Recording data file interval	[10 min] / [1 h]
Recording Time	Recording time	[1 to 59 s] / [1 to 59 m] / [1 to 24 h] / (Manual)
Pre Recording Time	Pre-recording time	[0 s] / [1 s] / [5 s]

<Trigger> menu (page 46)

Item	Description	Settings
Mode	Trigger mode	[Free] / [Single] / [Repeat]*3/ [Master]
Type	Trigger signal type	[Level] / [External] / [External Gate] / [Time]
Level	Trigger level *1	[0.1 to 0.9%] / [1 to 99%]
Ch	Trigger channel *1	[Ch1] to [Ch4]
Start Time	Start time *2	[2013/01/01 00:00] to [2037/12/31 23:59]
Stop Time	Stop time *2	[2013/01/01 00:00] to [2037/12/31 23:59]
Interval	Recording interval *2	[5 m] / [10 m] / [15 m] / [30 m] / [1 h] / [8 h] / [24 h]
Sleep	Sleep mode	[OFF] / [ON]
<p>*1 Trigger level and trigger channel to be set when trigger signal type is "Level".</p> <p>*2 Start time, stop time, and recording interval to be set when trigger signal type is "Time". When recording time is set to "Manual", "Interval" cannot be set.</p> <p>*3 When recording time is set to "Manual", trigger "Repeat" and "Single" have the same effect.</p>		

<Bar Graph> menu (page 50)

Item	Description	Settings
Graph	Bar graph display method	[Linear] / [Log]
Note	For channels where the sensor type is [MIC], [SLM], or [VM], the graph display method cannot be set. The bar graph is always in dB.	

<System> menu (page 51)

Item	Description/Operation	Settings
Read / Save Settings	Read or save the setting values	
Load default settings	Initialize the setting values to default	
Internal Memory (No. 1 to No. 5)	Apply or save the setting values to the unit	
SD CARD	Apply the setting values in the SD memory card to the unit, or save the setting values to the SD memory card	
Clock Settings	Current time setting	
Date	year, month, day	[2013/01/01] to [2037/12/31]
Time	hour, minute, second	[00:00:00] to [23:59:59]
Backlight Settings	Screen backlight setting	
Brightness	Backlight brightness	[1] to [4]
Auto-Off	Backlight auto-off timer	[30 s] / [3 m] / [Continue]
Battery Type	Type of batteries used	[Alkaline] / [Ni-MH]
Card Format	SD memory card format	
USB Storage	Connection to computer	[OFF] / [ON]
Monitor Out	Monitor Out connector function	[OFF] / [ON]
Index	Device index number	[1] to [255]
Version	Version information	

<Synchronization> menu (page 55)

Item	Description	Settings
Master / Slave	Assign roles when synchronizing two unit	[OFF] / [Master] / [Slave]
Synchronize	Synchronize two units	

Data recording

The unit offers 16 different (13 practical) combinations of recording time and trigger settings. The tables below list combinations that are useful from a practical point of view.

Data recording operation type							
	Recording time setting	Type	Mode	Parameter			
(1)	Recording Time 1 s to 24 h	–	Free	–	–	–	–
(2)		Level	Single	Level (Trigger level)	Ch (Trigger channel)	–	–
(3)			Repeat				
(4)		External	Single	–	–	–	–
(5)			Repeat				
(6)		Time	Single	Start Time	Stop Time	–	Sleep
(7)			Repeat			Interval (Recording interval)	
(8)	Manual	–	Free	–	–	–	–
(9)		Level	Single	Level (Trigger level)	Ch (Trigger channel)	–	–
(10)			Repeat*				
(11)		External	Single	–	–	–	–
(12)			Repeat*				
(13)		Time	Single	Start Time	Stop Time	–	–
(14)			Repeat*				
(15)	–	External	Single	–	–	–	–
(16)		Gate	Repeat				

"–": No setting item, "Repeat*" indicates that operation is essentially the same as for "Single"

Validity of pre-recording settings etc. depending on trigger conditions				
Trigger	Combination (previous table)	Pre-recording (Pre Recording Time)	Post-recording	Recording stop due to [STOP] key operation or insufficient SD memory card capacity
Mode Free	(1)(8)	○	×	○
Level	(2)(3)(9)(10)	○	×	○
External	(4)(5)(11)(12)	○	×	○
Time	(6)(7)(13)(14)	×	×	○
External Gate	(15)(16)	○	○	○
○: Function is valid ×: Function is not available Post-recording (5 seconds) function only for External Gate.				

Data recording: Recording time (1 s to 24 h), no trigger (1)

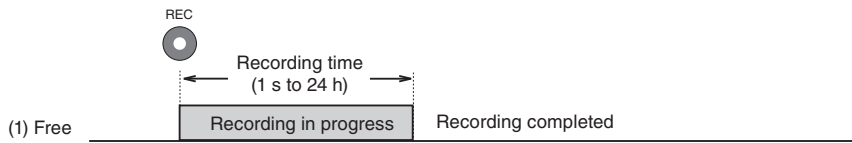

Data recording: Recording time (1 s to 24 h), Level trigger (2), (3)

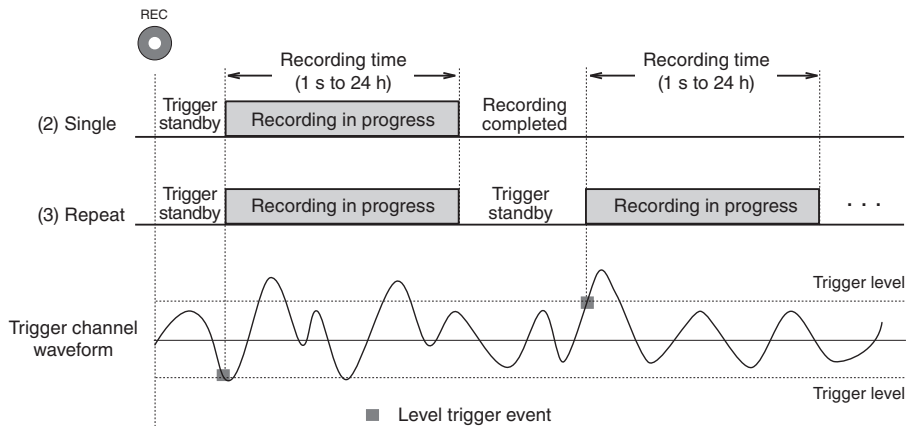

Data recording: Recording time (1 s to 24 h), External trigger (4), (5)

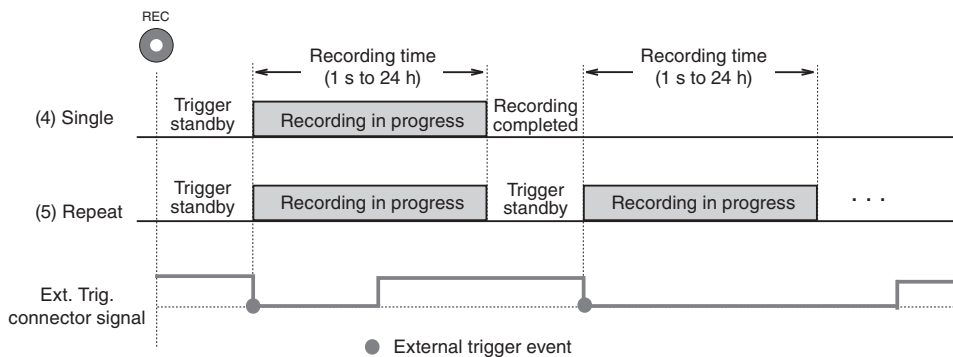

Data recording: Recording time (1 s to 24 h), Time trigger (6), (7)

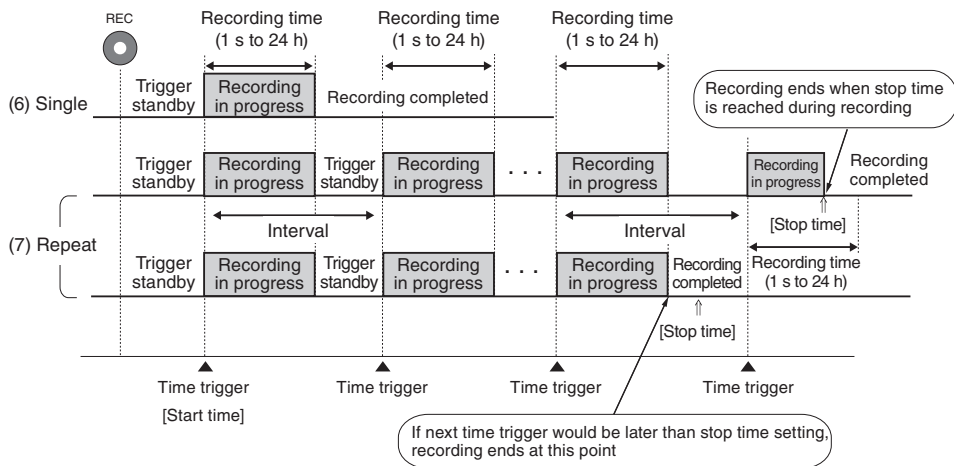

Data recording: Manual (controlled with [STOP] key), no trigger (8)

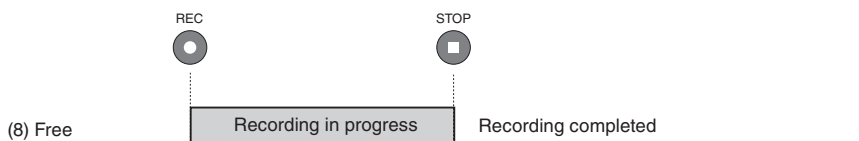

Data recording: Manual (controlled with [STOP] key), Level trigger (9), (10)

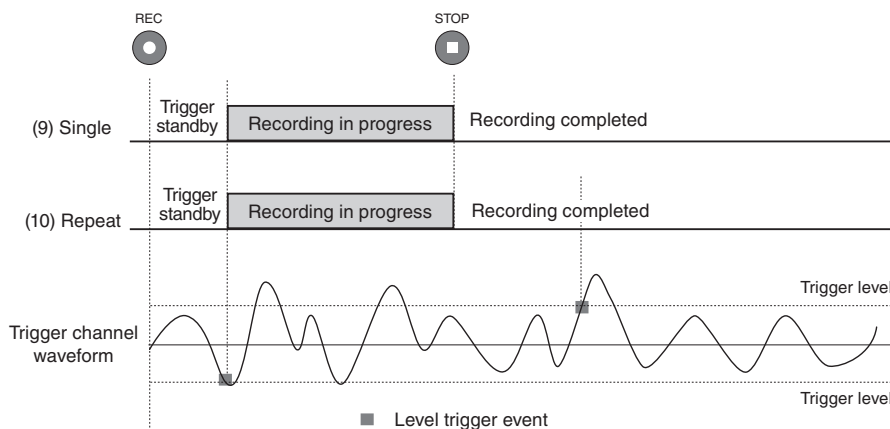

Data recording: Manual (controlled with [STOP] key), External trigger (11), (12)

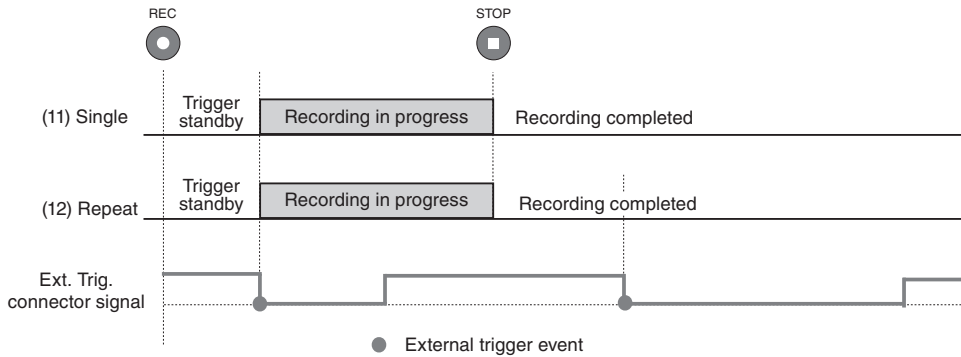

Data recording: Manual (controlled with [STOP] key), Time trigger (13), (14)

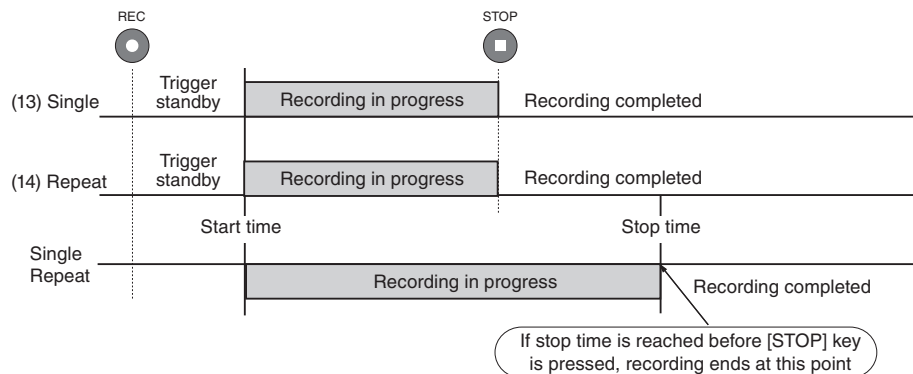

Data recording: Using gate signal (15), (16)

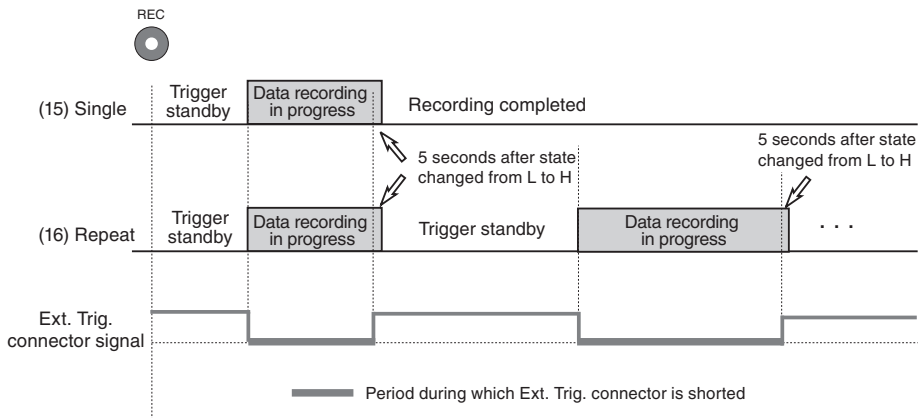

Representative value of inherent noise

Representative value of inherent noise of the unit which connected a sensor is shown in the table below. Those representative values are levelized by AS-70. (HPF setting and LPF setting of the unit are OFF.)

Sensors		Representative values		Remarks
		1 V range	0.01 V range	
PV-85 + VP-40		0.005 (m/s ²)	0.003 (m/s ²)	
PV-87 + VP-40		0.001 (m/s ²)	0.001 (m/s ²)	
PV-91C		0.027 (m/s ²)	0.023 (m/s ²)	
PV-97I	X	0.069 (m/s ²)	0.023 (m/s ²)	
	Y	0.065 (m/s ²)	0.021 (m/s ²)	
	Z	0.080 (m/s ²)	0.022 (m/s ²)	
PV-97C + VP-40	X	0.224 (m/s ²)	0.102 (m/s ²)	
	Y	0.215 (m/s ²)	0.095 (m/s ²)	
	Z	0.191 (m/s ²)	0.114 (m/s ²)	
NH-22A + UC-59	A	23.3 (dB)	12.3 (dB)	
	C	23.9 (dB)	19.5 (dB)	
	Z	32.6 (dB)	30.8 (dB)	
1000 pF dummy + VP-40		0.005 (m/s ²)	0.002 (m/s ²)	Sensitivity: 5 mV/(m/s ²)

Power save settings

Power consumption differs according to the usage condition of the unit. Using the unit with settings such as indicated below will help to conserve power.

- Screen backlight off (page 7, 53)
- Input (“Inp”) for unused channels (CH1 to CH5) set to “OFF” (page 39)
- Monitor Out set to “OFF” (page 54)
- Frequency Range set as low as possible (page 44)

WAVE File Format

This section provides details about the WAVE file format used by the unit.

Note

The WAVE file format of the DA-21 differs from that of DA-20 or DA-40.

Basic structure

The WAVE file is made up of variable-length blocks called “chunks”. The basic structure is as follows.

The chunks and file structure used by the DA-21 are shown below.

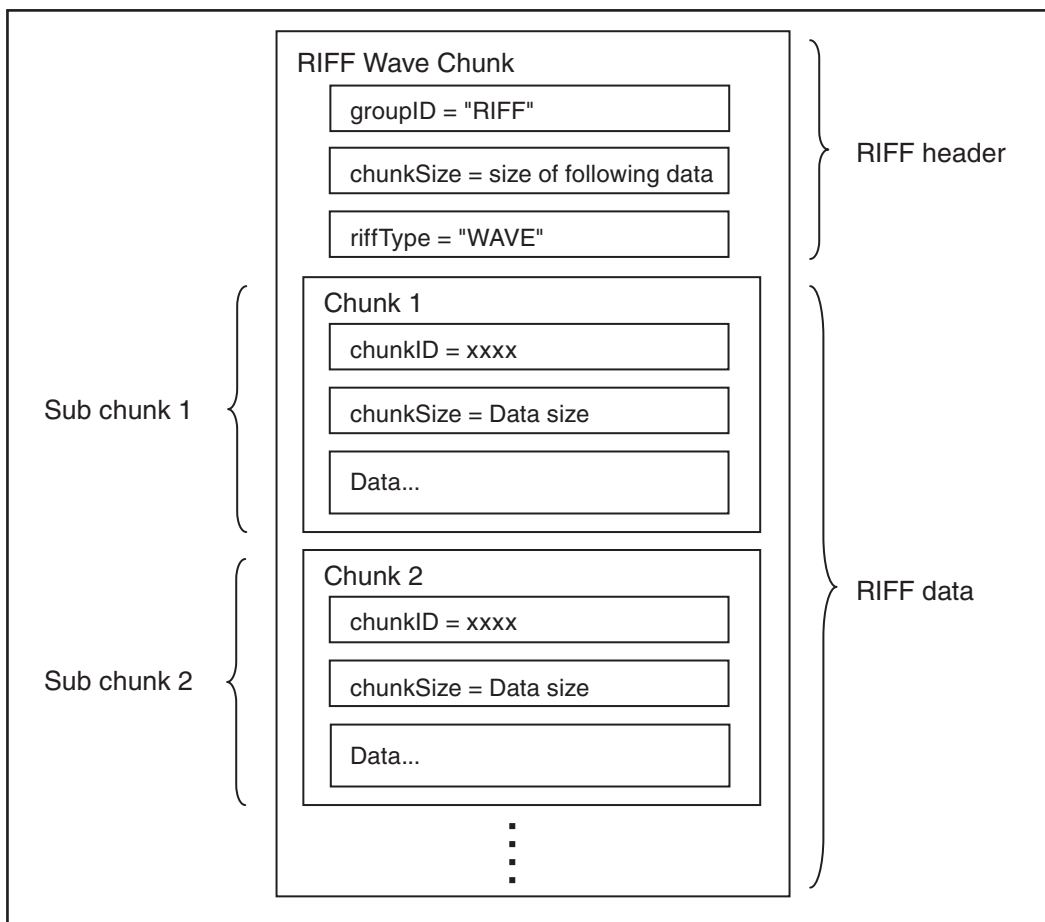

Basic WAVE file structure

The chunks and file structure used by the DA-21 are shown below.

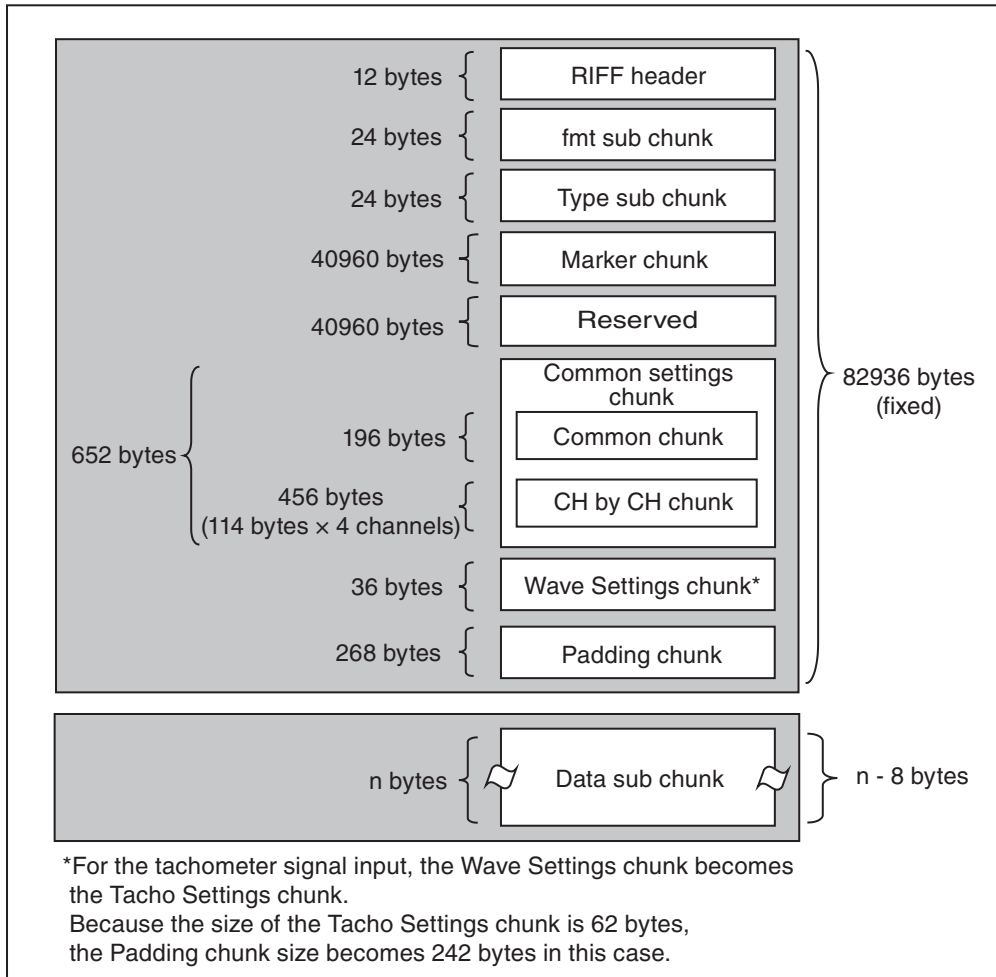

File structure and size

Invalid values

For unused items, a value defined as an invalid value is inserted.

The invalid values for the respective data types are shown in the table below.

Type	Invalid values
char	Blank
int16	Minimum value
uint16	Maximum value
int32	Minimum value
uint32	Maximum value
int64	Minimum value
uint64	Maximum value
float	Minimum value
double	Minimum value

Data types

The DA-21 uses the following specially defined data types.

```
typedef struct {
    uint32    dwDataAddress;    /* < Address as counted from start of data chunk    */
    uint32    dwDataSize;
    uint32    dwFatDateTime;
} MARKERFORMAT;
```

```
typedef struct {
    year :6;    /* < Year (offset from 2000)    */
    mon  :4;    /* < Month (1 to 12)    */
    day  :5;    /* < Day (1 to 31)    */
    hour :5;    /* < Hours (0 to 23)    */
    min  :6;    /* < Minutes (0 to 59)    */
    sec  :6;    /* < Seconds (0 to 59)    */
} FATDATETIME;
```

dwFatDateTime

The date is a packed value with the following format.

Bits	Values	Meaning
0 to 5	0 to 59	Second
6 to 11	0 to 59	Minutes (0 to 59)
12 to 16	0 to 23	Hours (0 to 23, 24-hour format)
17 to 21	0 to 31	Day of the month (1 to 31)
22 to 25	1 to 12	Month (1 = January, 2 = February etc.)
26 to 31	0 to 63	Year offset from 2000 (add 2000 to get actual year)

Chunks

The following tables provide details about the structure of the RIFF header (RIFF chunk) and the various sub chunks listed in the section “File structure and size” (page 140).

RIFF chunk

Table 1 RIFF chunk

Type	Variable name	Size (Byte)	Description	Value
char[4]	Chunk ID	4	Indicates RIFF	"RIFF"
uint32	Chunk Size	4	Total size of following data (not including this item)	Depends on recording parameters
char[4]	riffType	4	Indicates RIFF type	"WAVE"

fmt sub chunk

Table 2 fmt sub chunk

Type	Variable name	Size (Byte)	Description	Value
char[4]	Chunk ID	4	Indicates chunk type	"fmt_"
uint32	Chunk Size	4	Total size of following data (not including this item)	16
uint16	wFormatTag	2	Format type	0x0001
uint16	nChannels	2	Number of channels	1 to 4
uint32	nSamplesPerSec	4	Number of samples per second	See Table 3
uint32	nAvgBytesPerSec	4	Number of bytes per second	See Fig. 1
uint16	nBlockAlign	2	Block size	See Fig. 2
uint16	wBitsPerSample	2	Number of bits per sample	16 / 24

Table 3 nSamplesPerSec

Range Rate	100 Hz	500 Hz	1 kHz	5 kHz	10 kHz	20 kHz
2.4	240	1200	2400	12000	24000	48000
2.56	256	1280	2560	12800	25600	51200

$$nAvgBytesPerSec = nSamplesPerSec \times nChannels \times \frac{wBitsPerSample}{8}$$

Fig. 1 nAvgBytesPerSec

$$nBlockAlign = nChannels \times \frac{wBitsPerSample}{8}$$

Fig. 2 nBlockAlign

Type sub chunk

Table 4 Type sub chunk

Type	Variable name	Size (Byte)	Description	Value
char[4]	Chunk ID	4	Indicates chunk type	"TYPE"
uint32	Chunk Size	4	Total size of following data (not including this item)	16
char[8]	File Type	8	File type	"WR_____"
uint16	File Revision	2	Chunk format version number	1 or more
Reserved		6		

CommonShareSetting (common) chunk

Stores setting information of the unit, including trigger settings etc.

Table 5 CommonShareSetting (common) chunk

Type	Variable name	Size (Byte)	Description	Value
char[4]	Chunk ID	4	Indicates chunk type	"CSET"
uint32	Chunk Size	4	Total size of following data (not including this item)	644
char[12]	Product Type	12	Product designation	"DA-21_____"
uint16	Repeat Serial Number	2	Repeat trigger sequential number	Top number is 1, Nth number is <i>N</i>
uint16	File Serial Number	2	Split file sequential number	Top number is 1, Nth number is <i>N</i>
int64	Start Time	8	File start time	UNIX time
int64	Actual Record Time	8	Actual record time from Start Time	Time accuracy is 10 ms. Refer to the Wave Data chunk for the exact number of samples.
int16	Unit Equipped Channels	2	Number of total channels	4
int16	Total Enabled Channels	2	Number of enabled channels	1 to 4
Reserved		2		
Reserved		2		
Reserved		40		
Reserved		8		
char[16]	Unit Serial Number	16	Serial number	_____
int32	Unit CPU Version	4	CPU version	AA.BB.XXYY (8 digits in hex number)
int32	Unit DSP Version	4	DSP version	AA.BB.XXYY (8 digits in hex number)
int32	Unit CPLD Version	4	CPLD version	AA.BB.XXYY (8 digits in hex number)

Type	Variable name	Size (Byte)	Description	Value
int32	Unit SubMicon Version	4	Sub-microcomputer version	AA.BB.XXYY (8 digits in hex number)
int16	Trigger Mode	2	Trigger mode	0: Free 1: Single 2: Repeat
int16	Trigger Source	2	Trigger source	4: External 8: External Gate 16: Level 512: Time
int16	Trigger Channel	2	Trigger monitored channel	1 to 4
int32	Trigger Level Wave	4	Trigger level	Digit value in signed 16bit or 24bit is inputted by Int32 of MSB stuffing
Reserved		2		
Reserved		4		
int16	Trigger Slope	2	Trigger slope	Always 10
int64	Trigger Start Date Time	8	Trigger start time	UNIX time
int64	Trigger Stop Date Time	8	Trigger stop time	UNIX time
int32	Trigger Interval	4	Trigger interval	Second time scale
int16	Measure Frequency Range	2	Frequency range	3: 100 Hz 5: 500 Hz 6: 1 kHz 8: 5 kHz 9: 10 kHz 10: 20 kHz
int16	Measure Frequency Ratio	2	Frequency ratio (Sampling frequency / Frequency range)	0: 2.40 1: 2.56
int16	Tacho Codec Mode	2	Tacho meter codec mode	0: OFF 2: ON
int16	Synchronous Mode	2	Inter-unit synchronization mode	0: OFF 1: Master 2: Slave
Reserved		22		

CommonChSetting (each CH) chunk

Stores setting information of the unit, including each channel (for four channels) settings etc.

Table 6 CommonChSetting (each CH) chunk

Type	Variable name	Size (Byte)	Description	Value
Reserved		40		
int16	Chx Number	2	Channel number	1 to 4
int16	Chx Enabled	2	Channel input enable	0: false 1: true
Reserved		2		
int16	Chx Sensor Type	2	Sensor type	0: V 1: EU 2: MIC 3: PIC 4: SLM 5: VM
int16	Chx Sensor Input Range	2	Input voltage range (V_{peak})	102: 0.01 V (−40 dB) 103: 0.03 V (−30 dB) 104: 0.1 V (−20 dB) 105: 0.3 V (−10 dB) 106: 1 V (0 dB) 107: 3 V (10 dB) 108: 10 V (20 dB)
int16	Chx Coupling	2	Input coupling	0: AC 1: DC
int16	Chx CCLD	2	CCLD setting	0: false 1: true
int16	Chx Inversion	2	Input inversion	0: false 1: true
int16	Chx HPF Cutoff Frequency	2	High-pass digital filter cutoff frequency	0: OFF 1: 0.02 Hz 8: 5 Hz
int16	Chx LPF Cutoff Frequency	2	Low-pass digital filter cutoff frequency	0: OFF 4: 200 Hz 8: 1 kHz 12: 2 kHz
char[8]	Chx Measurement Unit	8	Unit	V EU dB m/s ²
double	Chx ValuePerBit	8	Calibration value (physical quantity per 1 bit)	Setting value on calibration
double	Chx ValuePerVolt	8	Calibration value (sensitivity)	Setting value on calibration

Type	Variable name	Size (Byte)	Description	Value
Reserved		8		
double	Chx Zero dB Reference (EU)	8	Calibration value (notation of 0 dB reference index)	Setting value on calibration
uint16	Chx Overload	2	Overload information in the file	0: No overload has occurred 1: Overload has occurred at least once
Reserved		2		
Reserved		10		

Wave Settings chunk

Table 7 Wave Settings chunk

Type	Variable name	Size (Byte)	Description	Value
char[4]	Chunk ID	4	Indicates chunk type	"WSET"
uint32	Chunk Size	4	Total size of following data (not including this item)	28
Reserved		2		
int16	Pre-time	2	Pre recording time	0 -1 -5
Reserved		24		

Tacho Settings chunk

Table 8 Tacho Settings chunk

Type	Variable name	Size (Byte)	Description	Value
char[4]	Chunk ID	4	Indicates chunk type	"TSET"
uint32	Chunk Size	4	Total size of following data (not including this item)	54
uint16	Pulse Per Rotation	2	Number of pulses per rotation	1
Reserved		2		
Reserved		2		
Reserved		8		
Reserved		8		
Reserved		8		
Reserved		24		

Padding chunk

Table 9 Padding chunk

Type	Variable name	Size (Byte)	Description	Value
char[4]	Chunk ID	4	Indicates chunk type	"padi"
uint32	Chunk Size	4	Total size of following data (not including this item)	Wave file: 260 Tacho file: 234
Reserved			Padding bytes to place the header on a 512 byte boundary	

Marker chunk

This chunk contains information about the start position and date/time of marker events during recording. Regardless of whether the WAVE file comprises marker data, the Marker chunk is always added.

Size is fixed to $12 \text{ bytes} \times 3412 + 8 + 8 = 40960$ bytes.

Upper limit is 3412 positions.

Dummy 8 bytes at the end are not used.

Table 10 Marker chunk

Type	Variable name	Size (Byte)	Description	Value
char[4]	ChunkID	4	Indicates chunk type	"memo"
uint32	ChunkSize	4	Total size of following chunk data (not including this item)	40952
MARKERFORMAT [3412]		40944		_____
uint32	dwDataAddress	(4)	Address from data top	_____
uint32	dwDataSize	(4)	Marker size (Bytes)	_____
uint32	dwDateTimeM	(4)	Date/time	_____
Reserved		8		

Wave Data chunk

Recorded raw waveform data are stored here.

Table 11 Wave Data chunk

Type	Variable name	Size (Byte)	Description	Value
char[4]	Chunk ID	4	Indicates chunk type	"data"
uint32	Chunk Size	4	Total size of following data (not including this item)	See Fig. 3
WAVEData	Data	Depends on recording time	Store the recorded raw waveform data	—

WAVEData follows the data conventions for regular WAVE files (16 bit/24 bit, little endian, 16 bit range full-scale value 25400, 24 bit range full-scale value 6502400).

$$\text{Chunk Size} = \text{nSamplesPerSec} \times \text{nChannels} \times \frac{\text{wBitsPerSample}}{8} \times [\text{Recording time (sec)}]$$

Fig. 3 Chunk Size

Specifications

Applicable standards

CE marking, UKCA marking, WEEE Directive, Chinese RoHS

Input section

Input connectors

Signal input × 4 (BNC)

Revolution speed (rotary pulse)

× 1 (BNC)

Voice memo input × 1

(voice memo microphone: 3.5 mm dia. 4-pole mini jack)

External trigger input

× 1 (2.5 mm dia. monaural mini jack)

Remote control × 1 (8-pin MINI DIN connector for Remote Controller (DA-20RC1))

Synchronous signal

× 1 (8-pin connector)

USB port × 1 (Mini-B connector)

Input range ±0.01 V, ±0.03 V, ±0.1 V, ±0.3 V, ±1 V, ±3 V, ±10 V

Note: The 0.03 V, 0.3 V, 3 V input range settings stand for 0.0316 V, 0.316 V, and 3.16 V actual values.

Input impedance 100 kΩ or more

Maximum input voltage

± approx. 13.0 V

Overload point Range full-scale +2.0 dB, tolerance ±1.0 dB

Input coupling AC/DC

(AC coupling [primary]: -3.0 dB ±1.0 dB at 0.315 Hz)

Sensor drive power (CCLD)

2 mA, 24 V

Digital filters

Cutoff slope: -12.0 dB/oct,

at filter frequency -3.0 dB ±1.0 dB

High-pass filter: OFF, 5 Hz

Low-pass filter: OFF, 200 Hz, 1 kHz, 2 kHz

Frequency response	DC coupling	DC to 1 Hz:	± 1.0 dB
		1 Hz to 12.5 kHz:	± 0.5 dB
		12.5 kHz to 20 kHz:	± 1.0 dB
	AC coupling	1 Hz:	± 1.0 dB
		1 Hz to 12.5 kHz:	± 0.5 dB
		12.5 kHz to 20 kHz:	± 1.0 dB
Inter-channel phase lag			
		1 deg max.	(AC coupling, HPF OFF, 10 V to 0.03 V range, same frequency range, 20 kHz range)
		3 deg max.	(AC coupling, HPF OFF, 0.01 V range, same frequency range, 20 kHz range)
S/N ratio: (within frequency band, including overload)			
	80 dB or more	(Input range: 10 V, 3 V, 1 V, 0.3 V)	
	75 dB or more	(Input range: 0.1 V)	
	70 dB or more	(Input range: 0.03 V)	
	60 dB or more	(Input range: 0.01 V)	
Offset			
	DC coupling (input shorted):		
	max. 2.0% of range full-scale (10 V, 3 V, 1 V)		
	max. 2.5% of range full-scale (0.3 V, 0.1 V)		
	max. 5.0% of range full-scale (0.03 V)		
	max. 10% of range full-scale (0.01 V)		
	AC coupling		
	max. 2.0% of range full-scale		
Distortion	$\pm 0.1\%$ or less (within frequency band)		
Voice memo function	2 operation modes		
	A: Recording in idle state		
	B: Revolution speed channel is always used as voice memo during recording		
	Revolution speed function is disabled while using voice memo function		
	* Marker function becomes also active during recording		

Rotary pulse

Input impedance	100 k Ω or more
Input voltage range	0 V to 10 V (Open collector supported, TTL supported)
Threshold level	+2.5 V
Counting method	Periodic counting
Measurable revolution speed range	200 rpm to 600,000 rpm (1 pulse / rotation)

Output section

Output connectors

Playback output	\times 4 (2.5 mm dia. monaural mini jack) playback recorded signal
Monitor out	\times 1 (3.5 mm dia. stereo mini jack) When recording: Analog signal output of a selected channel When playing back: Playback output (including voice menu) of a selected channel

Playback output

Playback output connector	
Output impedance	600 Ω
Frequency response	DC to 1 Hz: \pm 1.0 dB 1 Hz to 12.5 kHz: \pm 0.5 dB 12.5 kHz to 20 kHz: \pm 1.0 dB
Output voltage	\pm 3.16 V (corresponding voltage at range full scale)
Maximum output voltage	\pm 4.0 V
Offset	1.5% or less of maximum output
S/N ratio	72 dB or more (within frequency band, including overload)
Inter-channel phase lag	1 deg max. (within frequency band)

Monitor output connector	
Output impedance	100 Ω
Output voltage	± 3.16 V (corresponding voltage at range full scale)
Maximum output voltage	± 5.5 V
Offset	2.0% or less of maximum output (input range 1 V or higher)
Other specifications	Same as for input (frequency response, linearity, distortion)
Playback output selection	Output both from playback output and monitor output connectors
Recording section	
Recording media	SD memory card (Operation assured only with RION supplied SD memory cards) Maximum capacity: 32 GB
File system	FAT16, FAT32
A/D converter	24 bit quantization (quantization dynamic range 144 dB) Bit length can be selected from 16 bit or 24 bit
File format	WAVE (16 bit/24 bit linear, no compression)
Frequency range settings	100 Hz, 500 Hz, 1 kHz, 5 kHz, 10 kHz, 20 kHz
Sampling frequency settings	Frequency range $\times 2.4$ or $\times 2.56$
Maximum recording time	Approx. 23 hours (20 kHz range $\times 4$ channels, using 32 GB SD memory card)
Pre-recording	Data recorded 0, 1, or 5 seconds prior to start of recording or trigger event

Trigger section

Trigger source	External: Open collector supported (internal 3.3 V, 50 k Ω) <ul style="list-style-type: none">• External• External Gate (Compatible with comparator output of Sound Level Meter NL-62, NL-52, NL-42) Internal <ul style="list-style-type: none">• Level trigger (wave form): 0.1% to 0.9%, 1% to 99% of input range full-scale, linear peak• Time trigger: Recording is carried out repeatedly between preset start time and stop time, at specified intervals (sleep function settable)
Trigger mode	Free, Single, Repeat (divide into multiple files when repeat mode)
Pre-trigger	0, 1, or 5 seconds (pre-recording time before trigger event)
Calibration	
Readings	Linear (EU), Log (dB), can be set for each channel Main screen reading is linear only
Display	
LCD screen	Backlit monochrome TFT, 256 (H) \times 160 (V) dots
Display contents	Setting screen, recording screen, level bar graph, level history
LED indicators	Overload indication, remaining card capacity warning Status indicator for recording, playback, trigger standby, etc.
Language	English

Store settings	Five settings are stored in internal memory Startup file is available in the SD memory card
USB	
Mass storage class	Connected to a computer as a storage device, and recognized as a removable disk
Power supply section	
Power supply	Batteries or AC adapter (NC-98 series) Car battery adapter (CC-82)
AC adapter	Rated input: 100 V to 240 V AC, 50/60 Hz, 0.4 A Rated output: 5.9 V DC, 2 A, 11.8 W
Batteries	Four IEC LR6, size AA batteries (Alkaline batteries or Nickel metal-hydride batteries [Ni-MH])
External DC	5 V to 20 V
Battery life (representative value)	Temperature 23°C, backlight off, monitor out off, 32 GB card

Frequency range	Number of channels	CCLD ON	CCLD OFF	Batteries type
20 kHz	4	Approx. 4.5 hours	Approx. 8 hours	Alkaline
20 kHz	1	Approx. 7.5 hours	Approx. 10 hours	Alkaline
20 kHz	4	Approx. 7 hours	Approx. 10 hours	Ni-MH
20 kHz	1	Approx. 11 hours	Approx. 12 hours	Ni-MH

- * The capacity of the used Ni-MH battery is 2450 mAh
- * Battery life may differ significantly, depending on ambient temperature, unit settings, and brand and type of batteries and SD memory card

Inter-unit synchronization

Synchronized operation of two units allows simultaneous waveform level recording in up to 8 channels.

Other specifications

Dimensions	Approx. 140 mm (H) × 175 mm (W) × 45 mm (D)
Mass	450 g (not including batteries)
Fastening holes	1/4-20UNC (inch) screw hole on bottom panel

Operating environment

Temperature	-10°C to +50°C
Humidity	90% RH Max. (Non-condensing)
Altitude	2000 m Max.
Pollution	Degree 2
Installation	Category II

Ambient conditions for storage

-10°C to +50°C, max. 90% RH (no condensation)

Supplied accessories

IEC LR6 (size AA) alkaline battery	4
CD-ROM (Instruction manual, Viewer software AS-70 Viewer)	1
Inspection certificate	1

Optional accessories

AC adapter	NC-98 series
Car battery adapter	CC-82
Battery pack	BP-21A
SD memory card	
4-channel data recorder remote control unit	DA-20RC1
Voice memo microphone	MH-34B4B/SSM-17A (YAESU)
Monitor earphone	ATH-C320
Soft carrying case (with shoulder strap)	DA-20-007
BNC - BNC cable	NC-39A
BNC - BNC coaxial cable	EC-90 series
BNC - mini plug cable	CC-24
BNC adapter	VP-52C
Joint connector	VP-54C
Comparator output cable	CC-42C
(for connection to NL-62, NL-52, NL-42)	
Comparator output cable	CC-94A
(for connection to NL-21, NL-22, NL-31, NL-32)	
Inter-unit sync cable	CC-43
Condenser microphones (only electret type)	UC series
Preamplifier	NH-22A
Piezoelectric accelerometers	PV series
Charge converter	VP-40
Waveform analysis software	AS-70
Waveform analysis software	CAT-WAVE

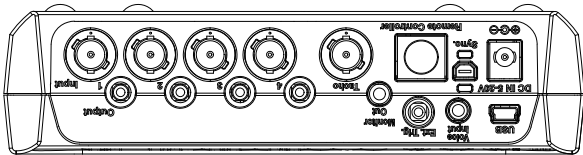

Top view

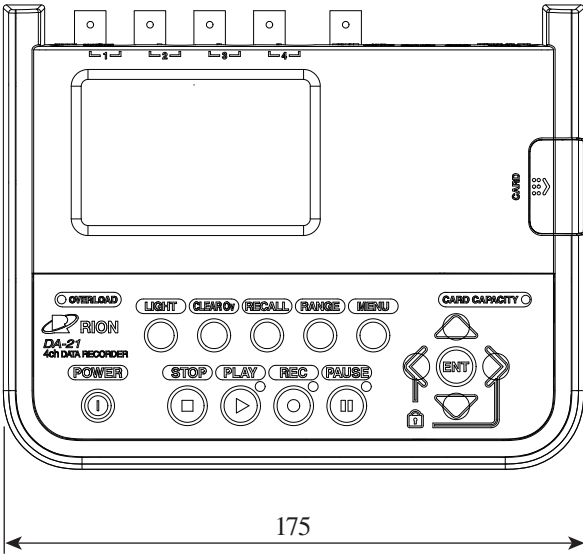

Front view

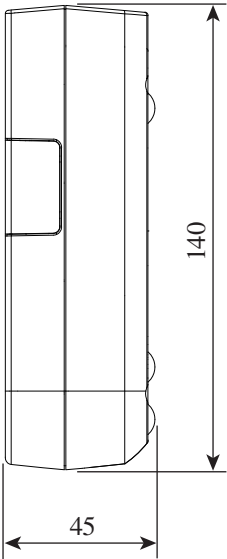

Right side view

Unit: mm

Dimensional Drawings

